



BC Passive
House Factory
Pemberton, BC



UBC Campus
Energy Centre
Vancouver, BC



StructureCraft
Manufacturing Facility
Abbotsford, BC

Industrial Buildings

A CASE STUDY

Canadian
Wood
Council

Conseil
canadien
du bois



WOODWORKS!
Program of the Canadian Wood Council



TABLE OF CONTENTS

- Introduction** 3
- BC Passive House Factory** 6
 - Design Approach
 - Setting a Precedent
- University of British Columbia Campus Energy Centre** 12
 - Design Approach
 - A Low Carbon Solution
 - A Hybrid Structure
 - Embodied Energy and GHG Emissions
- StructureCraft Manufacturing Facility** 17
 - A Kit of Parts
 - Engineering Innovations for Elegance and Economy
 - Dowel-Laminated Timber (DLT)
- Conclusion** 23
- Project Credits** back cover

Photo credits:

Pages 2/24 StructureCraft Builders	3.1 Ema Peter	4.1 StructureCraft Builders
2.1 Ema Peter	3.2 DIALOG	4.2 StructureCraft Builders
2.2 Hemsworth Architecture	3.3 Leung Chow	4.3 StructureCraft Builders
2.3 Ema Peter	3.4 Ema Peter	4.4 StructureCraft Builders
2.4 Hemsworth Architecture	3.5 DIALOG	4.5 StructureCraft Builders
2.5 Ema Peter	3.6 Ema Peter	4.6 StructureCraft Builders
2.6 Ema Peter	3.7 Robert Stefanowicz	4.7 StructureCraft Builders
2.8 Ema Peter	3.8 Ema Peter	4.8 StructureCraft Builders
2.9 Hemsworth Architecture	3.9 Fast + Epp	4.9 StructureCraft Builders
2.10 Hemsworth Architecture	3.10 Fast + Epp	4.10 StructureCraft Builders
2.11 Hemsworth Architecture	3.11 Fast + Epp	4.11 Wood <i>WORKS!</i> BC
2.12 Ema Peter	3.12 Ema Peter	4.12 StructureCraft Builders
2.13 Hemsworth Architecture	3.13 Fast + Epp	4.13 StructureCraft Builders
2.14 Ema Peter	3.14 Ema Peter	4.14 StructureCraft Builders
2.15 Ema Peter	3.15 Ema Peter	4.15 StructureCraft Builders
		4.16 StructureCraft Builders

INTRODUCTION



BC Passive House Factory

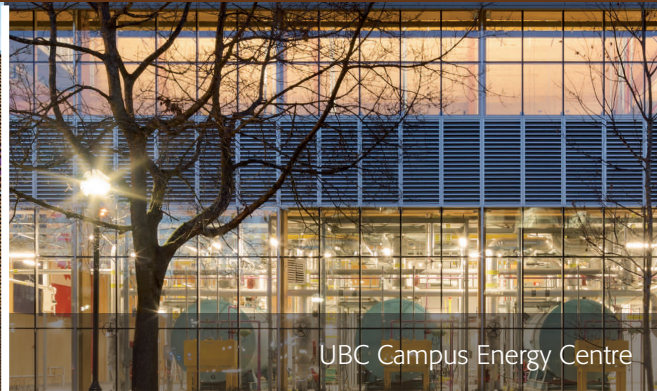

UBC Campus Energy Centre



StructureCraft Manufacturing Facility

Over the past two decades, new engineered mass timber products and construction techniques have changed the way we think about wood as a building material. Historic perceptions about strength, durability and fire performance have been overturned by scientific evidence and full-scale testing of prototype structures.

As a result, mass timber has begun to make its mark in the residential and commercial sectors, particularly on Canada's West Coast. However, the market for industrial buildings continues to be dominated by tilt-up concrete and steel-frame construction, both of which have a significant environmental footprint. Tilt-up concrete in particular has inherent disadvantages;

concrete cannot be poured in the freezing conditions typical of Canadian winters, nor can it be easily insulated to reduce the operating energy requirements of the building.

However, the National Building Code of Canada states that a roof assembly in a building of up to two storeys is permitted to be of heavy timber construction regardless of the building area or the type of construction required, provided the building is sprinklered. In addition, the structural members in the storey immediately below the roof assembly are also permitted to be of heavy timber construction. These requirements apply equally to industrial buildings, meaning that heavy timber is a

viable alternative to the materials traditionally used, and single storey industrial buildings may be constructed entirely of heavy timber.

This case study examines three recently completed industrial buildings in southern British Columbia, each of which uses engineered mass timber products and systems in a distinct and different way. Together, they offer insights into how industrial construction might evolve to offer greater environmental performance, speed and flexibility of construction, at little additional cost over traditional methods.

BC Passive House Factory

PEMBERTON, BC

The design of this factory in BC's spectacular Pemberton Valley reflects the quality of the components it produces: prefabricated wood roof, wall and floor panels for high performance buildings. The structure, parts of which meet the Passive House standard for energy conservation, was constructed at a cost comparable to that of a traditional tilt-up concrete building.

Fig. 2.1: BC Passive House Factory



UBC Campus Energy Centre

VANCOUVER, BC

This hybrid structure includes a significant volume of regionally manufactured mass timber products, both cross-laminated timber (CLT) panels, and glued-laminated timber beams and columns. The use of mass timber components significantly reduces the construction carbon footprint of the building when compared to the more familiar steel and concrete equivalents.

Fig.3.1: UBC Campus Energy Centre





StructureCraft Manufacturing Facility

ABBOTSFORD, BC

This factory produces both custom wood structures and mechanically-fastened dowel-laminated timber (DLT) panels for the local and international markets. The 40,000-square-foot workshop is built up from a simple kit of parts comprising glued-laminated timber columns and beams, loadbearing high-bay wall panels and long-span roof panels. It was constructed in just five days.

Fig. 4.1: StructureCraft
Manufacturing Facility

“This is the second time we have used CLT in an industrial building on the UBC campus - the first being the Bioenergy Research and Demonstration Facility. Based on our positive experience with that project, it was a natural choice for the Campus Energy Centre. We have found CLT to be durable and cost competitive with steel.”

Paul Holt, Director, Energy and Utilities -
University of British Columbia

“Our team aimed to develop a signature structure that would expand on what’s possible with wood. Not only did we quickly and efficiently construct a cost-effective industrial building, this project showcases the advantages of building with engineered wood for the industrial buildings of tomorrow.”

Lucas Epp, Engineering Manager –
StructureCraft Builders

“We don’t look at any building as ‘just construction.’ If a building can connect with somebody, and that usually happens with the use of the site and the use of materials, then the building will elevate itself. We were lucky to have a very interested client, to be able to explore some of these ideas, still within a strict budget, but in my opinion this should be happening everywhere: in municipal halls, in elementary schools and other everyday buildings we spend our days inhabiting.”

John Hemsworth, Principal - Hemsworth
Architecture

BC Passive House Factory



Fig. 2.1: The rectangular volume of the building is clad entirely in wood

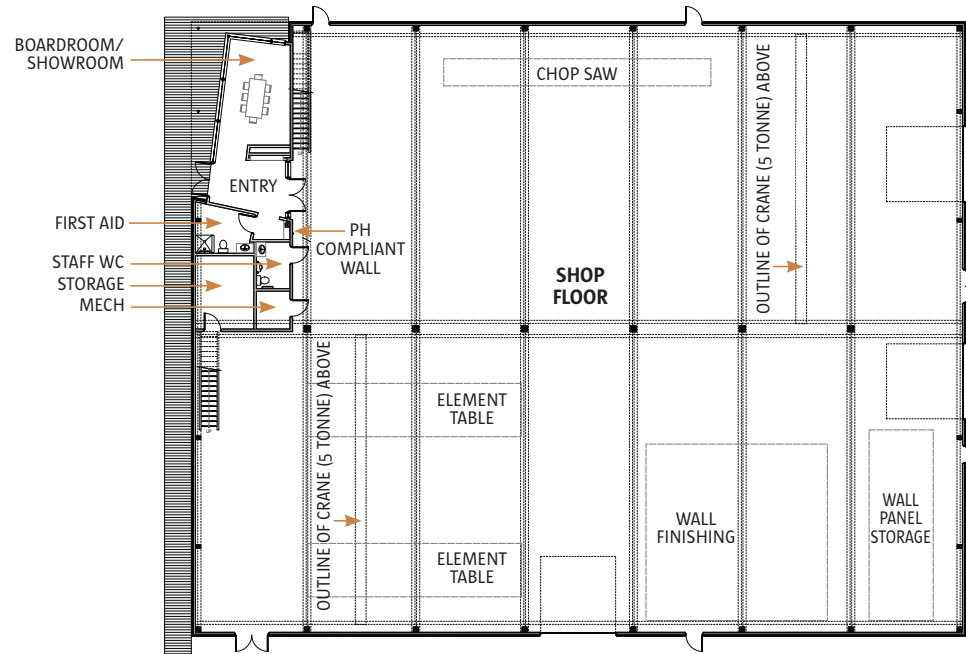

Fig. 2.2: The program includes the factory floor, mezzanine office and a showroom

Located in Pemberton, BC, this 15,000-square-foot manufacturing facility was completed in 2014. It comprises a large high-bay workshop, a mezzanine office area and a small showroom all contained within a single rectangular volume (Figures 2.1 and 2.2). BC Passive House (BCPH) grew out of co-owner Matheo Dürfeld's previous construction company that built Canada's first Passive House structure, known as Austria House, for the 2010 Winter Olympic Games in Whistler.

At that time, Passive House, an ultra-low energy approach to building that originated in Germany in the 1980s, was

almost unknown in Canada, and the super-insulated, factory prefabricated components for Austria House were manufactured in Europe before being shipped to British Columbia for assembly on the Whistler site. While Dürfeld continued to promote the Passive House approach as a way to radically decrease the environmental impact of buildings, particularly in regard to operating energy, there was little or no demand in the local market. Within a few years however, the situation changed; the Canadian Passive House Institute (now Passive House Canada) was formed, and Dürfeld was finally able to scale up his operations and construct a permanent manufacturing facility.

Design Approach

BCPH had budgeted for a conventional tilt-up concrete building, but following a trip to prefabrication facilities in Europe, its aspirations changed. It recognized that its own factory could offer a much better working environment to employees, and have enhanced marketing value, if it embodied the same principles as the buildings it would be producing: low energy, prefabrication, healthy materials and assemblies, and sustainability on a life cycle basis. The challenge for Hemsworth Architecture would be to achieve all of this within the same budget.

What followed was an integrated design process in which the client, architect and structural engineer combined their expertise to create a building that was economical and efficient to construct. As realized, the BC Passive House Factory embodies the design objectives as follows:

Low Energy: The office and showroom areas were designed to meet the Passive House Standard with super-insulated floors, walls and roof (Figures 2.3 and 2.4), reducing the energy required for heating and cooling by more than 85 per cent when compared with a building designed to code. Super-insulation for the shop space was not deemed necessary, as a temperature range of 10-15°C was considered ideal for active work (Figure 2.5).

Prefabrication: Manufacturing envelope components in a controlled environment improved precision and minimized the possibility of damage from exposure to weather.

Healthy Materials and Assemblies: The super-insulated panels for the office area were analyzed using advanced building science techniques. Air tightness was combined with vapour-open construction, enabling moisture-laden air to diffuse to the outside, minimizing the risk of condensation and mould growth.

Sustainability: Materials and products were chosen for their low life cycle impact on the environment. BCPH's selection criteria favoured wood and wood byproducts, these being

natural, renewable and either recyclable or biodegradable at the end of their primary service life. This reduced the related CO₂ emissions by approximately 971 tonnes of CO₂ when compared to a similar concrete building, and 306 tonnes of CO₂ when compared to a similar steel building.¹ The conference room was finished with re-milled salvaged cedar, while pumice and recycled foam glass insulation were used beneath the floor slabs to minimize the use of expanded polystyrene.



Fig. 2.3: The showroom and office areas are constructed to the Passive House Standard

¹ CO₂ production values were obtained from www.co2list.org

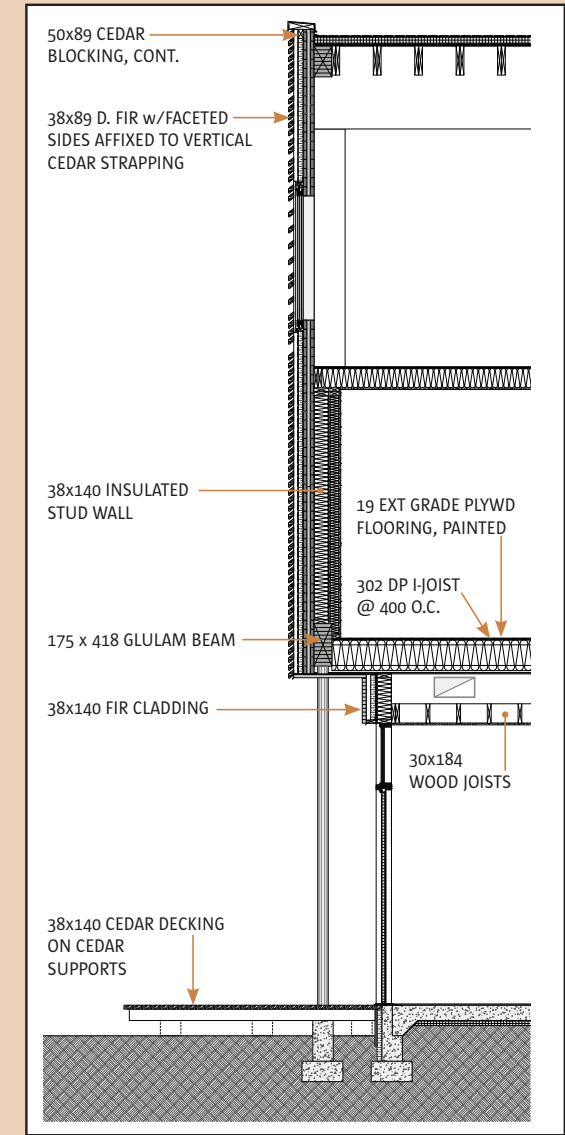

Fig. 2.4: The super-insulated walls are of vapour-open construction

The result is a precedent setting structure that speaks to the value of good design, even for this most prosaic of building types (Figures 2.6 and 2.7).



Fig. 2.5: Interior of factory area



Fig. 2.6: BCPH sets a new standard for the design of industrial buildings



Fig. 2.7: Abundant daylight and exposed wood finishes give the interior a warm and inviting quality

Setting a Precedent

The BCPH Factory is located on an industrial estate east of the town centre, and encircled by the mountains of the Coast Range. Clad entirely in unfinished fir and larch boards, it sits in contrast to its concrete neighbours, and fits comfortably into the dramatic landscape of the Pemberton Valley (Figure 2.8).

The main structure of the building consists of Douglas fir post-and-beam frames running east to west across the building and set 20 feet apart. A central line of columns divides the factory into two bays, reducing the span, depth and cost of the roof beams (Figure 2.9). Each roof beam has continuous ledgers on both sides, which provide support and simplify the installation of roof panels.



Fig. 2.9: The central line of columns reduces the depth and cost of the roof structure



Fig. 2.8: The building fits comfortably into its immediate landscape context

The roof assembly consists of on-site prefabricated panels framed with 2x10-inch solid sawn members and sheathed with plywood. Dimensionally consistent and easy to secure, the roof panels kept the structure square and stable during the erection process, eliminating the need for additional bracing (Figure 2.10). The exterior walls are made from solid spruce/pine/fir (SPF) cross-laminated timber (CLT) panels laid horizontally. The 20-foot column spacing was chosen to optimize the use of CLT, which is manufactured to a maximum length of 40 feet. Each row of panels is offset from the one below, avoiding continuous vertical joints that would compromise the diaphragm action of the walls (Figure 2.11).



Fig. 2.10: The roof panels sit on ledgers attached to the glulam beams

The CLT panels are exposed on the interior of the building, creating a warm, comfortable, and inspiring workspace. Above the CLT, a continuous clerestory wraps around all four sides of the building. This provides an unprecedented level of natural light that changes in character as the day progresses. It also

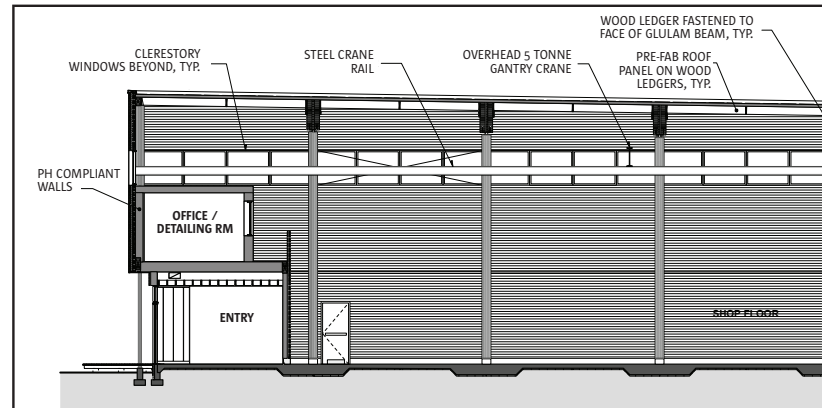

Fig. 2.11: Partial building section: The CLT wall panels span two structural bays, and are staggered to improve diaphragm action

means that the workers have views to the mountains in all directions (Figure 2.12). The structural engineers at Equilibrium Consulting designed steel cross-bracing to connect the roof and wall diaphragms, while minimizing the obstruction of views.



Fig. 2.12: Clerestory windows on all sides offer panoramic views of the mountains

The building exterior is finished in horizontal 2x4-inch fir and larch boards, chamfered on two edges and pre-assembled into panels (Figure 2.13). The boards were laid up in a jig, enabling the spacing between boards to be varied in a controlled manner. Vertical backing members were then attached to facilitate installation of the panels.

Varying the openness of the screens enabled the exterior appearance to remain consistent, while allowing each façade to respond to its own particular solar orientation. On the south and west façades, the slats over the clerestory windows are closely spaced to provide solar shading, while those on the north and east façades are more open to maximize views. The cladding is left unfinished and will weather with each season until it reaches a silver-grey colour (Figure 2.14). This proved to be an economical façade to construct, with the added benefit that it required no paints or stains.

As noted previously, the office and showroom spaces are designed to the rigorous Passive House Standard. Using BCPH's airtight, double-walled system and high performance wood windows, the envelope was optimized to dramatically reduce the energy required for heating and cooling. A high efficiency heat recovery ventilation unit provides a constant supply of fresh air to the office, making for a healthier work environment.

A biomass wood-fed boiler utilizes the wood waste from the manufacturing process to provide heat that is distributed to the plant through an in-floor radiant heat system. This provides a solution for plant waste while supplying the building with a carbon-lean heat source.

The facility is the first of its kind in North America and assists the company in its promotion of the Passive House Standard and sustainable, energy-efficient construction methodologies that use innovative wood-based construction materials (Figure 2.15).



Fig. 2.15: The building itself is an advertisement for the advanced wood components made within



Fig. 2.13: Prefabricated wall panel with fir and larch slats



Fig. 2.14: The wood cladding is left unfinished, and will weather to a grey colour over time

UBC Campus Energy Centre



Fig. 3.1: The CEC reveals its inner workings to passers-by on the UBC campus

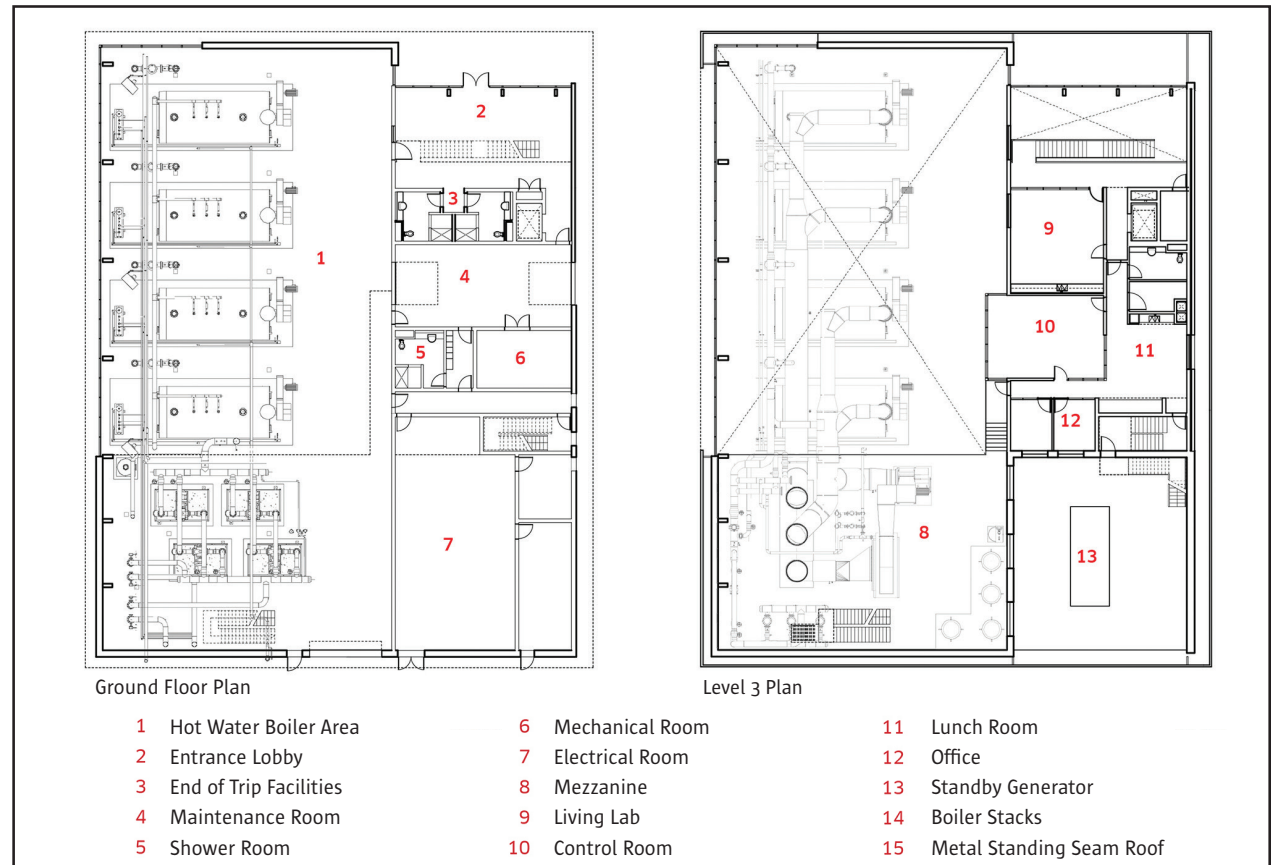

Fig. 3.2: The program includes the factory floor, mezzanine office and a showroom

The UBC Campus Energy Centre (CEC) is the beating heart of a new hot water district energy system that serves more than 130 buildings on the University of British Columbia's Point Grey campus in Vancouver. Completed in 2015, the CEC replaces a steam-based district heating system dating from the 1920s (Figures 3.1 and 3.2).

Because it operates more efficiently and is able to use lower grade heat than its predecessor, the CEC has reduced the overall energy consumption on the campus by 22 per cent and helped UBC achieve its ambitious goal to reduce its GHG emissions by 33 per cent compared to 2007 levels. The three 15-megawatt gas-fired boilers produce enough thermal energy to meet 100 per cent of the university's current needs. The facility is designed to accommodate a fourth boiler as UBC and its energy demands continue to grow.

Design Approach

The 20,000-square-foot facility consists of a 60-foot-high boiler room (Figures 3.4 and 3.5) that includes a mezzanine, and a two-storey office and administration area with standard ceiling heights (Figure 3.6). Juxtaposing these program elements creates a stepped cross-section that, when combined with the multiple penetrations of the building envelope for intake ducts, exhaust flues and other mechanical and electrical services, could have resulted in a disparate and disorderly appearance, at odds with the surrounding buildings.



Fig. 3.4: View of boiler bay from mezzanine

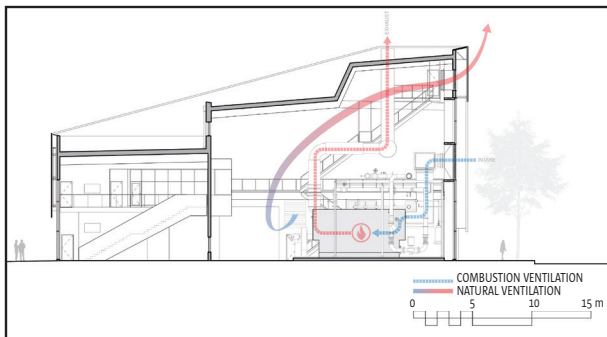

Fig. 3.5: Building section through boiler bay



Fig. 3.6: The two-storey office component is constructed with concrete masonry

A Low Carbon Solution

As a public institution with a large real estate portfolio, the University of British Columbia is concerned not simply with the initial cost of its buildings, but with their overall life cycle performance. Life Cycle Assessment (LCA) considers both the embodied energy and operating energy of buildings, together with a range of other potential environmental impacts.

With an international reputation for environmental leadership and construction innovation, the choice to use wood for the primary structure of the Campus Energy Centre was a natural one for UBC. The campus already boasts several innovative mass timber buildings, including the Centre for Interactive Research on Sustainability (CIRS), the Bioenergy Research and Demonstration Facility (Figure 3.3), the Earth Sciences Building, and Brock Commons Tallwood House – the world’s tallest hybrid mass timber building at the time of construction. For these projects, the environmental advantages of wood, which include carbon storage, low-embodied energy, durability and recyclability — all of which contribute to superior life cycle performance — were key.

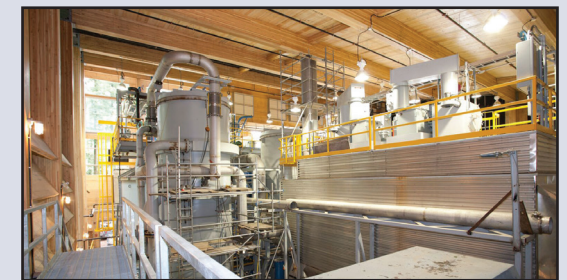

Fig. 3.3: The UBC Bioenergy Research and Demonstration Facility, designed by McFarland Marceau Architects

A Hybrid Structure

To unify the appearance of the building, the architects at DIALOG devised an exterior screen of zinc panels, supported on a framework of light gauge steel. This permeable skin, which floats 12 feet above the ground plane and is held 3 feet off the building structure, was manipulated to provide transparency, weather protection and announce entry points (Figure 3.7). The panels are perforated where required for air intake louvres or other service penetrations, and solid elsewhere. On the west elevation, adjacent to the sidewalk, the screen rises above a large area of glazing to reveal the inner workings of the boiler room. Interpretive signage reinforces the informal learning opportunity for passers-by.



Fig. 3.7: The exterior zinc screen rises at the corner to reveal the main entrance

Also revealed through these windows is the primary structure of the boiler process area, a Douglas fir glued-laminated timber (glulam) post-and-beam frame, with infill walls of seven-ply (9.5-inch-thick) cross-laminated timber (CLT) panels. The sloping roof is also constructed using CLT panels which span the full width of the space (Figure 3.8).

The 60-foot-high spruce/pine/fir (SPF) CLT walls create a continuous enclosure around the mechanical equipment, giving the vast space a sense of warmth unusual in an industrial building. All materials were sourced in British Columbia and fabricated by Structurlam in Penticton, BC.

The apparent simplicity of the structure is the result of some innovative details devised by structural engineers, Fast + Epp. While the CLT walls of the boiler room appear to be continuous, the height of the space exceeded the 40-foot maximum length of panels currently available. This necessitated the stacking of two panels, one on top of the other, above and below a horizontal glulam beam (Figure 3.9). To maintain the visual continuity of the exposed surface, the upper and lower panels (both 9.5 inches thick) are machined with a half lap profile that conceals the beam and creates a neatly mated joint. Where loads are greatest, the glulam beams and columns are replaced with hollow square section steel members (Figure 3.10).

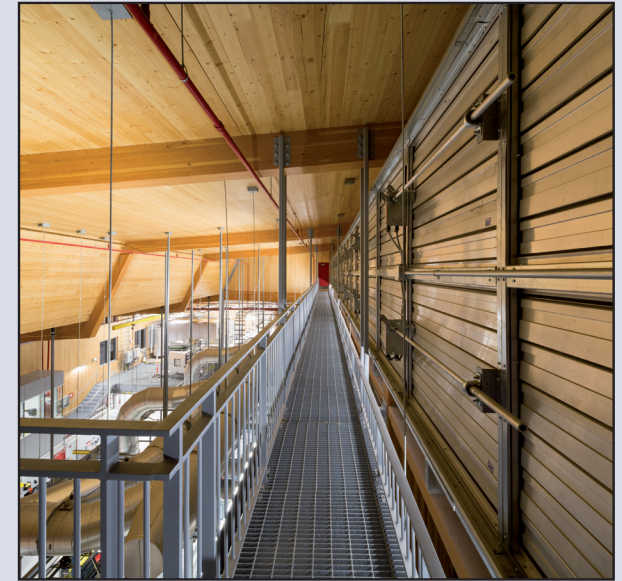

Fig. 3.8: The sloping roof also features structural CLT panels



Fig. 3.9: CLT wall panels are stacked vertically and secured to the glulam frame

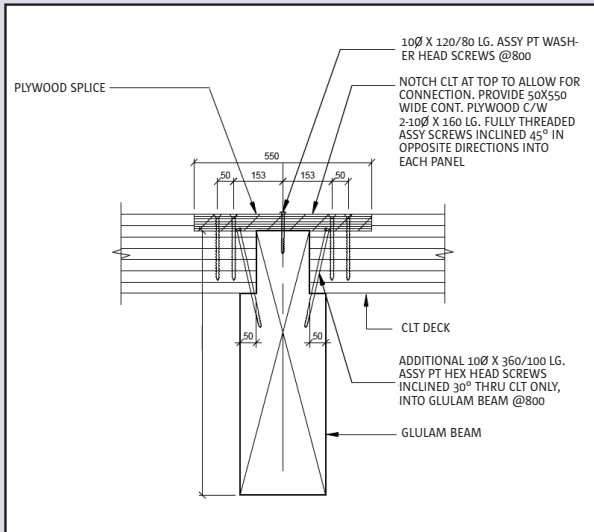

Fig. 3.10: Detail of steel section used to reinforce CLT walls where lateral loads are highest

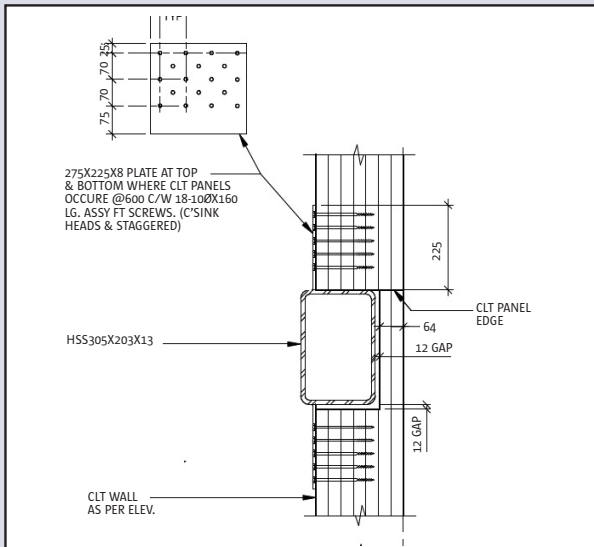

Fig. 3.11: Connection detail between glulam columns and beams

The CLT wall panels are notched to accept the glulam beams and designed to resist both the dead load of the roof, and the lateral loads imposed by wind and seismic forces. On the west side of the building, where the CLT wall panels are omitted to permit views into the boiler room, roof panels are supported on a glulam beam. The connections between the CLT panels (wall-to-wall, wall-to-roof, or roof-to-roof) are made using pairs of long stainless steel screws, set at opposing 45 degree angles in what is referred to as a Dragon's Claw configuration. This enables both walls and roof to act as diaphragms and contribute to the lateral system of the building. A similar connection is used between the CLT panels and the glulam frame members (Figure 3.11).

The roof of the boiler room is divided into three sections; the upper and lower sections having a shallow slope, and the mid-section being much steeper. This mid-section is supported by an inclined truss, concealed from below by the CLT ceiling (refer to Figure 3.8). The truss is a hybrid wood-steel truss (Figure 3.12). The steel carries the majority of the load, but the wood (both CLT and glulam) provides significant stability to the members that would otherwise experience buckling issues.

The administration block, which includes a ground floor electrical room that required a two-hour fire-resistance-rated enclosure, also necessitated a hybrid structural solution. It was not economical to use CLT in this situation, so the electrical room is enclosed with concrete masonry walls. The walls for the office area above, where the required FRR is only one hour, CLT walls were used.



Fig. 3.12: Hybrid truss used in steeply sloping portion of roof

Embodied Energy and GHG Emissions

The structure of the CEC is pragmatic, employing different structural materials as dictated by function. On this basis, CLT and glulam elements were chosen wherever they would be most economical and effective (Figure 3.13). In comparison to an all-steel equivalent (the construction type most commonly used for this kind of building), the hybrid wood system reduces the overall construction carbon (the sum of the GHG emissions associated with the extraction, processing, fabrication, transportation and installation of all building components) by 88.3 (CO₂ equivalent) tonnes (Figure 3.13).

With its exterior cloak of zinc and glass, the building fits comfortably into its campus context, while the exposed wood interiors create a warm and inviting environment for employees (Figures 3.14 and 3.15).



Fig. 3.14: The building fits comfortably into its campus context



Fig. 3.13: The wood components lower the construction carbon footprint of the building, compared to concrete or steel construction

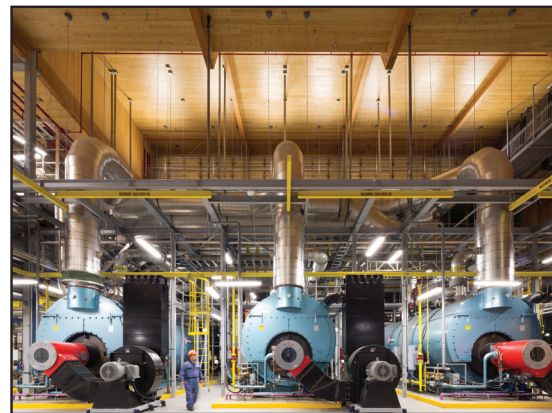

Fig. 3.15: The exposed wood interior creates a warm and welcoming environment for employees

StructureCraft Manufacturing Facility

StructureCraft is one of North America's leading mass timber design/build firms, with a track record of innovative projects dating back to the late 1990s. At that time, Gerry Epp was a principal with Fast + Epp Structural Engineers and had designed a glulam and steel truss roof for the new Pacific Canada Pavilion at the Vancouver Aquarium. When tenders for the project came in well over budget, Epp, believing the bids were unreasonable, offered to build it himself. Architect Bing Thom backed the idea; the client was persuaded, and StructureCraft Builders Inc. was born.

Since then, StructureCraft has designed, fabricated and installed many landmark mass timber structures in Canada and around the world: the roofs of the Richmond Olympic Oval and VanDusen Visitor Centre in British Columbia; the P.J. Currie Dinosaur Museum and Bow River Bridge in Alberta; and the roof and supporting structures of the Arena Stage Theatre in Washington, DC, and the Tsingtao Visitor Centre in China. The growing volume of work has outstripped the capacity of StructureCraft's original facility in Delta, BC, prompting the company to design and construct a new fabrication plant for its ongoing operations.

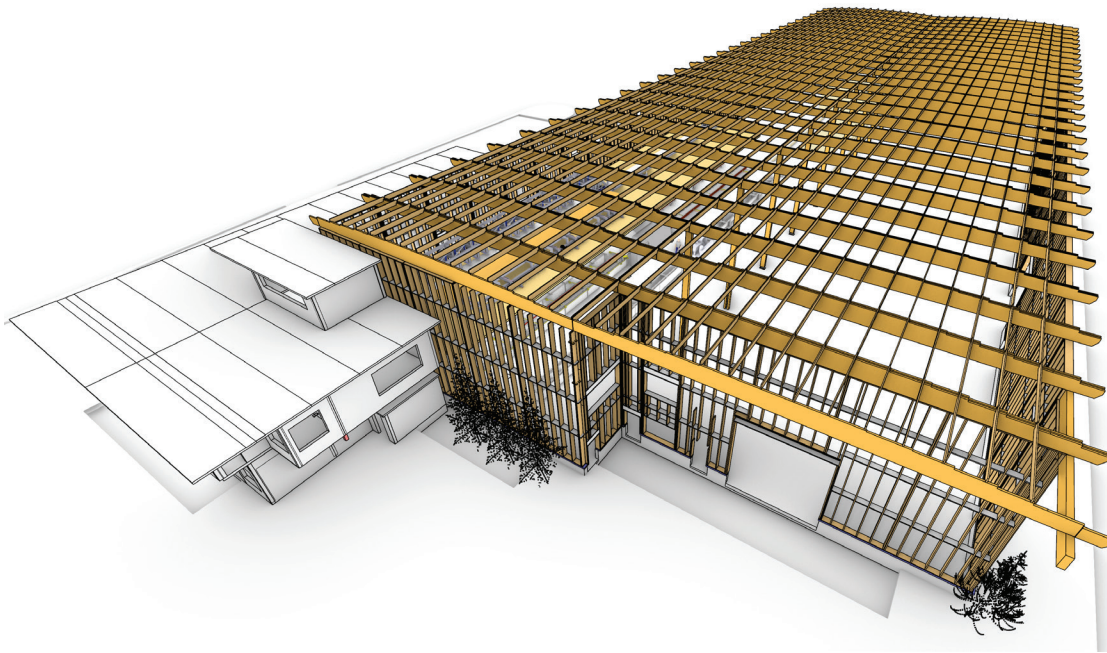

Fig. 4.2: 3D model of the structure



Fig. 4.1: Although they appear to be a single building, the office and factory areas are structurally distinct

Scaling Up

With a total area of 50,000 square feet, the new facility in Abbotsford, BC is twice the size of its predecessor. The complex includes two buildings, visually connected but structurally separate; a 120x360-foot warehouse and workshop space, and an L-shaped administration building (Figures 4.1 and 4.2).

A Kit of Parts



Fig. 4.5: Wall panel being placed

The warehouse, which was constructed in just five days, consists of prefabricated ‘tall wall’ panels, each measuring 12 feet wide and 30 feet high; and roof panels, each 12 feet wide and 63 feet long, that span between the perimeter walls and a central longitudinal glulam beam (Figure 4.3). The roof panels were preconstructed on site with glulam-edge beams, bridged laterally by conventional solid-sawn joists; while the wall panels have laminated strand lumber (LSL) studs (Figures 4.4 and 4.5).

All the wall panels were factory finished with plywood sheathing inside and out, fiberglass insulation, and an exterior moisture barrier. These panels arrived by truck from the Delta facility and were lifted directly into place (Figure 4.6 – following page). The wall panels, which carry the roof loads at the perimeter of the building, were held in the vertical position by temporary shores until the requisite roof panel was installed – from which point the structural bay was stable (Figure 4.7).



Fig. 4.3: Interior of factory showing central line of columns

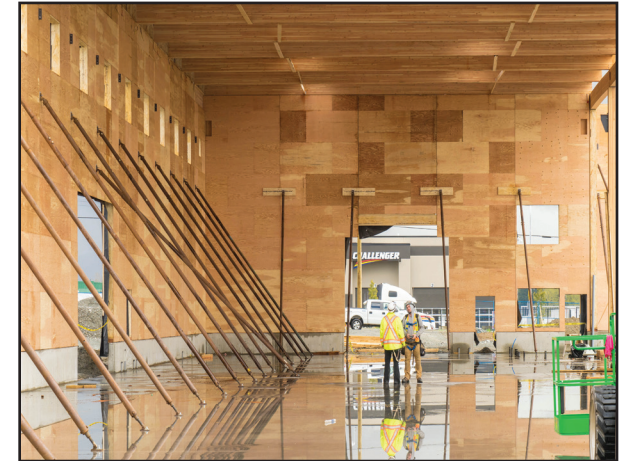

Fig. 4.7: Temporary shores were used to stabilize walls prior to installation of roof panels



Fig. 4.4: Roof panel being lifted into place

The roof panels were connected in the field with a second layer of plywood, laid in a staggered pattern and overlapping the joints between panels. Glued in place, the two layers of plywood form a continuous roof diaphragm, transferring seismic and wind forces to the vertical structure and hence to the ground. The central glulam beam, upon which the end of the panels bear, is supported on glulam columns at 24-foot centres (Figure 4.8). These columns divide the interior into two long rectangular spaces, one of which is dedicated to the custom fabrication projects for which StructureCraft is already well known, the other to the manufacture of dowel-laminated timber (DLT) panels (more details on page 22). The large column spacing permits the passage of lifting equipment, materials and prefabricated assemblies as needed.



Fig. 4.8: Roof panels span between exterior walls and central glulam beam



Fig. 4.6: Full-height wall panels

Engineering Innovations for Elegance and Economy



Fig. 4.9: The end walls with openings were designed as coupled shear walls, eliminating the need to provide cross-bracing for lateral resistance

This apparently simple building contains a number of innovative engineering solutions designed to make the structure more efficient and economical.

The end wall contains two large openings, a feature that would normally require the addition of cross-bracing elsewhere in the building to achieve the required shear resistance. In this case, however, the StructureCraft engineers designed the shallow sections of wall above the doors (which would not normally be considered in load calculations) as continuous beams that contributed to the overall lateral resistance of the wall. Thus, no additional bracing was required (Figure 4.9).

The glulam edge beams that support the roof panels have a curved profile that perform multiple functions: each beam follows the shape of the bending moment diagram and is thicker mid-span where the forces are greatest, and thinner at the supports where these forces are lowest. This saves material and hence cost, but also creates a slope in the roof for required drainage (Figure 4.10).



Fig. 4.10: The cambered roof beams create a sloping roof surface that facilitates drainage

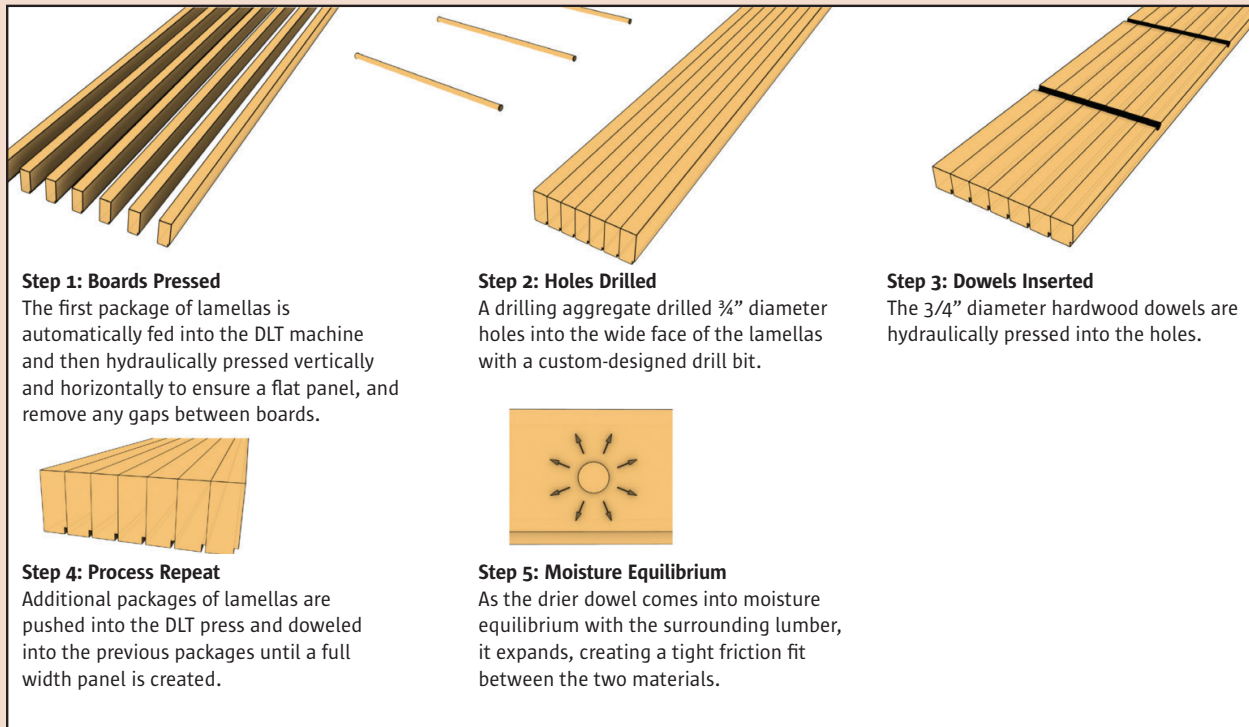

Fig. 4.12: DLT panel

The central glulam beam supports four gantry cranes, which would normally require additional bracing steel to resist the lateral forces developed when a moving load is brought to rest. Instead, the StructureCraft engineers devised a shoulder connection between the glulam columns and beams that enabled the columns to be connected directly to the roof diaphragm, and so transmit these forces without additional cost (Figure 4.11).

These efficiencies, the comprehensive application of prefabrication techniques, and the speed of construction, have resulted in a structure that was delivered at a cost comparable to that of a conventional tilt-up concrete or steel-frame equivalent. Furthermore, the embodied energy of the structure is significantly lower, and the operating energy cost (by virtue of the insulated envelope) is also likely to be lower.

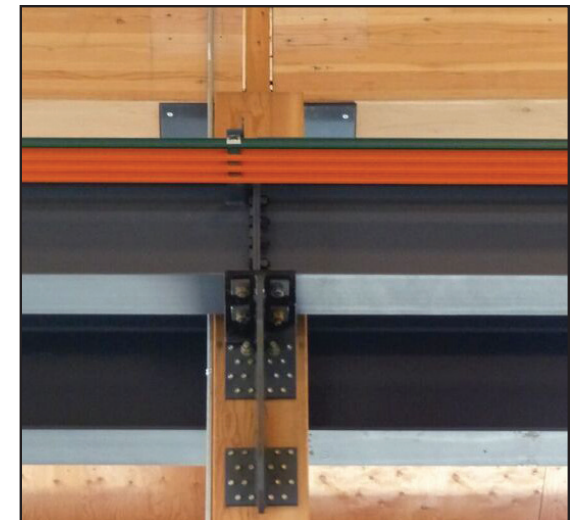

Fig. 4.11: Column-to-beam connection at gantry crane

Dowel-Laminated Timber (DLT)

An important purpose of the new StructureCraft facility, beyond the increased capacity it offers for custom prefabrication work, is to accommodate equipment for the manufacture of an innovative mass timber product that is new to North America. Dowel-laminated timber (DLT) has certain things in common with the more familiar nail-laminated timber (NLT) that has been used on many recent commercial projects. Like NLT, DLT is a one-way spanning panel that is made up from multiple laminations of solid sawn lumber fastened together face-to-face (Figures 4.12 and 4.16).

However, whereas NLT is hand-built and the carpenter must use his or her strength and skill to compensate for any warping or other inconsistencies in the solid sawn material, the manufacture of DLT is a mechanized process, in which the boards are first milled, then compressed together by a machine. NLT panels are held together by nails, which makes any subsequent modification problematic; whereas DLT is fastened together using only wood dowels and can therefore be machined using CNC equipment or hand tools.

The mechanical bond between the solid sawn lumber planks and the dowels that secure them relies on the careful control of the moisture content (MC) of these two components. While the softwood boards may be at an MC between 15 per cent and 19 per cent, the hardwood dowels are dried to a much lower MC. Being hygroscopic (able to absorb and release moisture), the wood in each panel will naturally establish a consistent moisture content throughout. This means that the dowels, already designed to be a tight fit, will expand to create a mechanical bond of enormous strength.



Fig. 4.13: Exterior of office building



Fig. 4.14: DLT panels in the office area



Fig. 4.15: Feature wood stair in the office area

CONCLUSION

Neither the nails in NLT nor the dowels in DLT are contributing to the strength of the panel (unless, in the case of NLT, the boards are longitudinally staggered to achieve a longer span). Rather, they simply enable the laminated boards to be manipulated and installed as a single panel. The boards in DLT panels are not staggered, however lengths of up to 60 feet are achievable using finger-jointed boards.

The automated manufacturing process for DLT also means that every board can be run through a profiler prior to assembly. This offers a variety of possible soffit treatments, including grooves to accept absorbent material to improve acoustic performance. The office portion of the building (Figure 4.13) has been used as a showcase for the new DLT material, with the wall and roof panels displaying a variety of profiles (Figures 4.14 and 4.15). Lastly, DLT is fastened together without glue (except for the minuscule amounts that are present in any finger-jointed material).



Fig. 4.16: The building is clad in a rainscreen system of unfinished Alaskan yellow cedar boards

Although different in their design and execution, the three buildings in this case study share a common theme. Each embodies the values of the organization that commissioned them and, in the case of the BC Passive House Factory and the StructureCraft Manufacturing Facility, built them as well. In a sector of the construction industry where economy and utility have long been the sole drivers of design, these projects add other criteria. They are all healthy and attractive workplaces that support employee well-being and demonstrate that good design has a valuable role to play in every aspect of the built environment.

Despite heavy timber structures being permitted under most building codes for single-storey industrial buildings, they are not well represented in industrial applications. In this context, the buildings in this case study offer an inspiring and economically viable alternative to the many industrial buildings commonly made of concrete and steel. In addition, wood offers considerable environmental advantages. The approximately 0.9 tonnes of CO₂ stored in each cubic metre of wood translates into significant reductions in the construction carbon footprint when wood can be substituted for these more carbon-intensive materials.

PROJECT CREDITS

BC PASSIVE HOUSE FACTORY

Client: BC Passive House

Architect: Hemsworth Architecture

Structural Engineer:

Equilibrium Consulting

General Contractor: Dürfeld Constructors

Engineered Wood Supplier:

Structurlam Mass Timber Corp.

UBC CAMPUS ENERGY CENTRE

Client: University of British Columbia

Architect: DIALOG

Structural Engineer: Fast + Epp

General Contractor: Ledcor

Engineered Wood Fabricator:

Structurlam Mass Timber Corp.

Engineered Wood Installer:

StructureCraft Builders

STRUCTURECRAFT MANUFACTURING FACILITY

Client: StructureCraft Builders

Architect: Keystone Architecture

Structural Engineer:

StructureCraft Builders

General Contractor:

StructureCraft Builders

Engineered Wood Fabricator:

Structurlam Mass Timber Corp.



NATIONAL FUNDER

PROVINCIAL FUNDER



Natural Resources
Canada

Ressources naturelles
Canada



Forestry Innovation
Investment

NATIONAL PARTNERS



StructureCraft



INDUSTRY FUNDERS

PROVINCIAL PARTNERS



Boise Cascade
Engineered Wood Products



FOR MORE INFORMATION ON WOOD WORKS!, CONTACT: www.wood-works.ca • WOOD WORKS! HELP DESK: help@woodworks.org

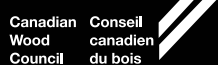

BC Program
1-877-929-9663

Alberta Program
1-780-392-1952

Ontario Program
1-866-886-3574

Québec Program
1-418-650-7193 ext. 413

Atlantic Program
1-902-667-3889

National Office
1-800-463-5091

US Program
1-858-243-1620