

Figure 9.8
**Manufacture of
Pressure-
Treated Wood**

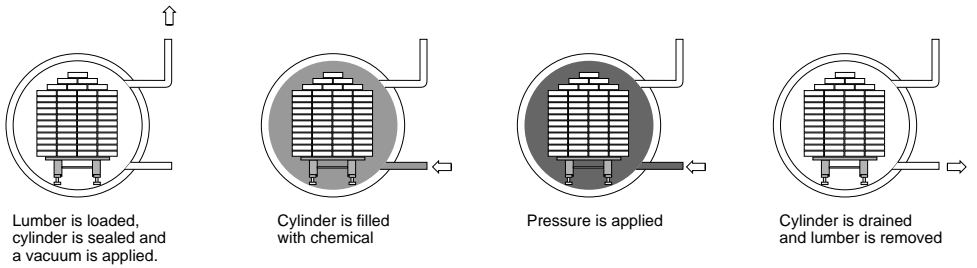
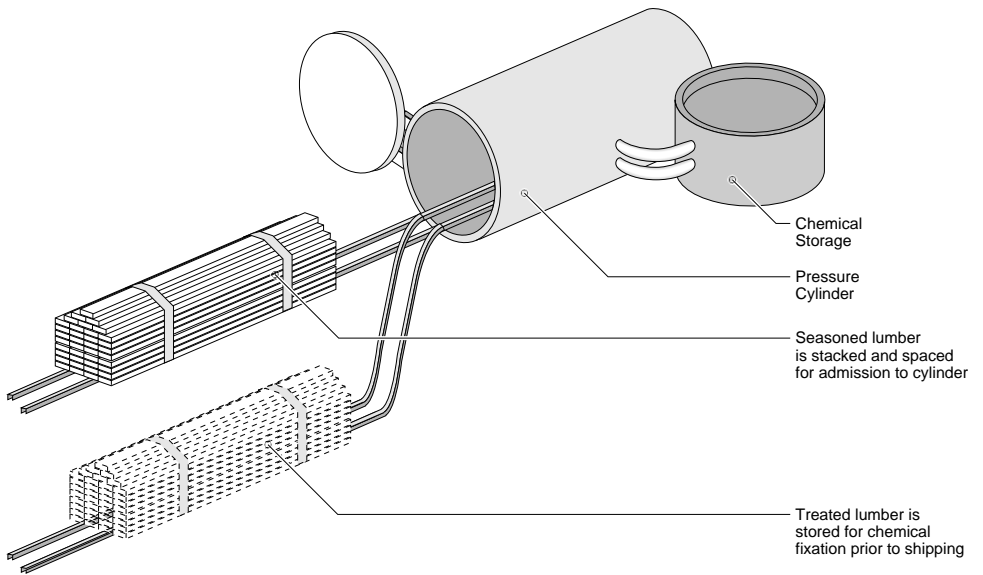

Figure 9.9
**Cross Section
of Preservative
Treated
Lumber**

