



Mid-Rise Best Practice Guide

Proven Construction Techniques
for Five-and Six-Storey
Wood-Frame Buildings



Contents

- 3 Introduction
- 4 Featured Projects
- 14 Design for Increased Dead and Live Loads
- 21 Controlling Shrinkage and Differential Movement
- 25 Fire Safety and Noise Control
- 31 Building Envelope Considerations
- 34 Construction Practices
- 39 Environmental Benefits of Wood Construction
- 41 Cost Benefits of Wood Construction
- 42 Conclusions
- 44 Project Credits

The Canadian Wood Council and Wood *WORKS!* BC wish to acknowledge and thank BC Housing for funding and support for this publication.

About BC Housing

BC Housing develops and administers a wide range of initiatives supporting different housing options across British Columbia (BC). In partnership with the private and non-profit sectors, provincial health authorities and ministries, other levels of government and community groups, BC Housing increases affordable housing solutions for British Columbians.

Under the Homeowner Protection Act, BC Housing is mandated to help improve consumer protection for buyers of new homes and the quality of residential construction in BC. BC Housing fulfils this mandate by monitoring and enforcing the mandatory third-party home warranty insurance on all new homes constructed in BC, licensing residential builders and maintaining a registry of new homes, and performing research and education functions to advance and promote better building and retrofit practices to benefit BC's residential construction industry and consumers.



www.bchousing.org

Photo credits:

- 2.1, 5.1, 5.2**
Adera Development Corporation
- 2.2, 2.3**
Rositch Hemphill Architects
- 2.4, 2.5, 2.6**
KPL James Architecture Inc.
- 2.7, 2.8, 2.9, 3.1, 3.6, 4.2, 4.3, 4.4, 4.5, 5.3, 5.7, 6.3, 7.2**
MGA | Michael Green Architecture
- 2.10:**
Raef Grohne, Courtesy: Integra Architecture Inc.
- 2.11, 3.5, 5.4, 6.4**
Integra Architecture Inc.
- 2.11**
P + A Landscape Architects
- 2.13, 3.2**
Derek Lepper
- 2.14, 2.15, 3.7, 3.8, 5.5, 6.2**
Raymond Letkeman Architects Inc.
- 3.3, 3.4**
Read Jones Christoffersen Ltd.
- 3.9, 5.6, 6.1, 7.4**
Rositch Hemphill Architects
- 4.1**
Kimberley Wahlström
- 6.5, 7.1**
Jim Taggart
- 6.6**
Nic Lehoux, Courtesy MGA | Michael Green Architecture
- 7.3**
VanMar Constructors Inc.
- 8.1**
www.certificationcanada.org
- 8.2**
Karine Wolfe/ Kimberley Wahlström
- Page 3, 43, 44**
Sail, Raef Grohne



1. INTRODUCTION

When the provincial government changed the **British Columbia Building Code (BCBC)** in 2009 by increasing the permissible height for wood-frame construction from four storeys to six for residential buildings, it joined many other jurisdictions around the world in recognizing the role that wood construction should play in the creation of a sustainable, built environment.

Scientific evidence and independent research had shown that such buildings could meet the performance requirements of the BCBC in regard to structural integrity, fire safety, and life safety. That evidence has now also contributed to the addition of new prescriptive provisions for wood construction, as well as paved the way for future changes that will include more permissible uses and ultimately greater permissible heights.

As a result of this research, and the successful implementation of many mid-rise wood-frame residential buildings in BC, the **Canadian Commission on Building and Fire Codes** approved similar changes to the National Model Construction Codes. The 2015 edition of the National Building Code of Canada (NBC) now permits the construction of six-storey residential,

business, and personal services buildings using traditional combustible construction materials. The changes to Part 3 of the NBC, which are being considered for adoption by British Columbia in late 2018, address the objectives of safety, fire, and structural protection of buildings.

With more than 100 five- and six-storey wood-frame buildings completed in BC since 2009, and many others either designed or under construction, there is clear market confidence in this new type of building. This construction supports the goals of many municipalities: to find affordable and sustainable ways to accommodate their growing populations, as well as create more complete and resilient communities.

With each completed building, architects, engineers, builders, and developers have added to their knowledge base and refined their best practices for mid-rise wood-frame construction. The five projects featured in this publication are representative of the diverse and varied application of these techniques to different geographic and market conditions, from small towns to dense urban centres and from affordable rental accommodation to high-end condominiums.

2. FEATURED PROJECTS

Sail, Vancouver, BC

Completion: 2014

Sail is a two-phase market condominium project in the Wesbrook Place neighbourhood, a 95-acre “urban village” under development on the Point Grey campus of the University of British Columbia. The Phase 1 and 2 buildings include a total of 170 apartment units (Figure 2.1).

The buildings are six storeys in height, constructed using traditional light wood framing for walls, engineered wood joists for floors, and occasional engineered wood posts, beams, headers, and lintels where load requirements dictate. The wood-frame structure is built on top of a two-storey underground parking garage of reinforced concrete construction (Figures 2.2 and 2.3).

In this much coveted location, the apartments at Sail include high-end finishes and fixtures, large balconies, in-floor radiant heating, and nine-foot ceilings.



FIGURE 2.1 – SAIL IS A TWO-PHASE MARKET CONDOMINIUM PROJECT LOCATED IN THE WESBROOK PLACE NEIGHBOURHOOD OF THE UNIVERSITY OF BRITISH COLUMBIA CAMPUS IN VANCOUVER



FIGURE 2.2 – SAIL: PHASE 1 SITE PLAN



FIGURE 2.3 – SAIL: PHASE 1 BUILDING CROSS-SECTION

Herons Landing & The Ardea, Saanich, BC

Completion: 2014

This two-phase project is located in the District of Saanich on southern Vancouver Island. The largest municipality in the Capital Regional District, Saanich is experiencing rapid growth and a shortage of affordable housing. Offering 104 micro suites, ranging in size from 340 sq. ft. studios, to 920 sq. ft. three-bedroom units, Herons Landing and The Ardea were designed for single, minimum-wage earners, students, seniors, and others in need of affordable rental accommodation (Figure 2.4).

Herons Landing has five residential storeys in wood frame on one commercial storey in concrete. The Ardea has four residential storeys in wood frame on two above-grade parking storeys in concrete (Figures 2.5 and 2.6). The lower cost of mid-rise wood-frame construction made this much-anticipated project economically viable. The Ardea and Herons Landing are the first new rental buildings to be constructed in Saanich in 25 years, and the first six-storey wood-frame buildings on Vancouver Island.

In addition to traditional light wood-frame construction, both Herons Landing and The Ardea buildings include engineered wood I-joint floors, some engineered posts, beams and headers, and a nail-laminated timber (NLT) elevator shaft.



FIGURE 2.4 – HERONS LANDING, TOGETHER WITH THE ARDEA, IS THE FIRST RENTAL HOUSING PROJECT TO BE BUILT IN SAANICH IN 25 YEARS

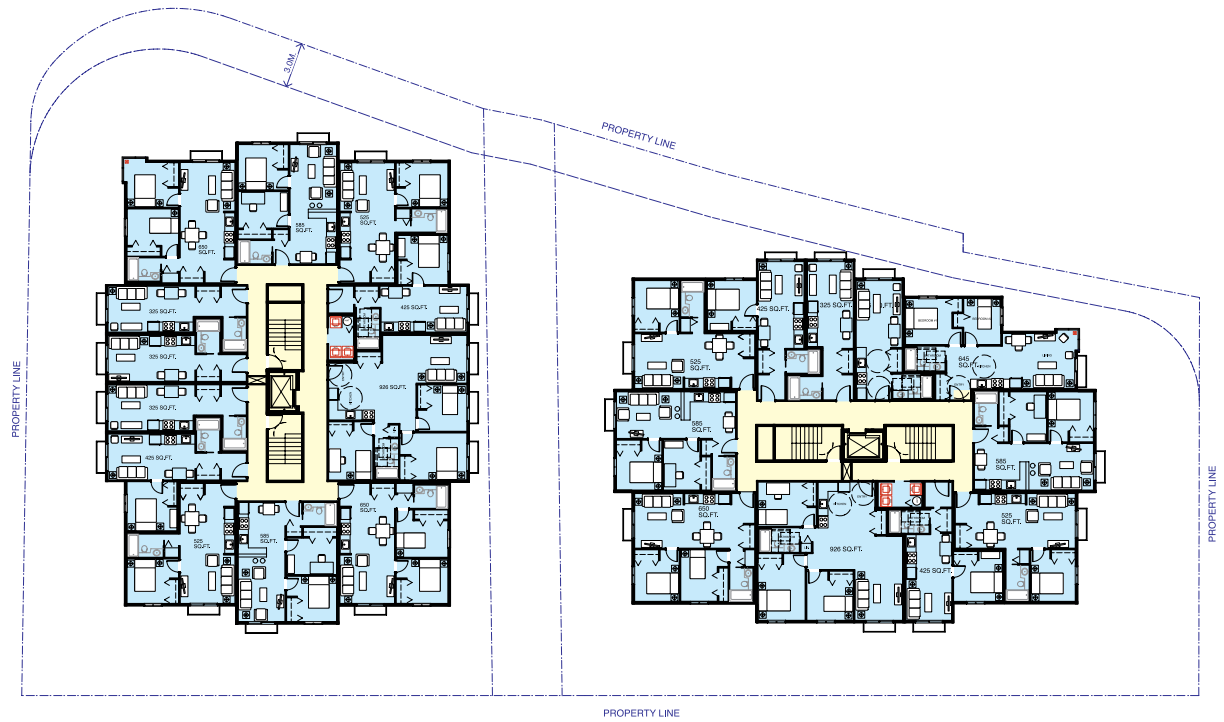

FIGURE 2.5 - HERONS LANDING AND THE ARDEA: TYPICAL UPPER FLOOR PLANS IN PHASE 1 & 2

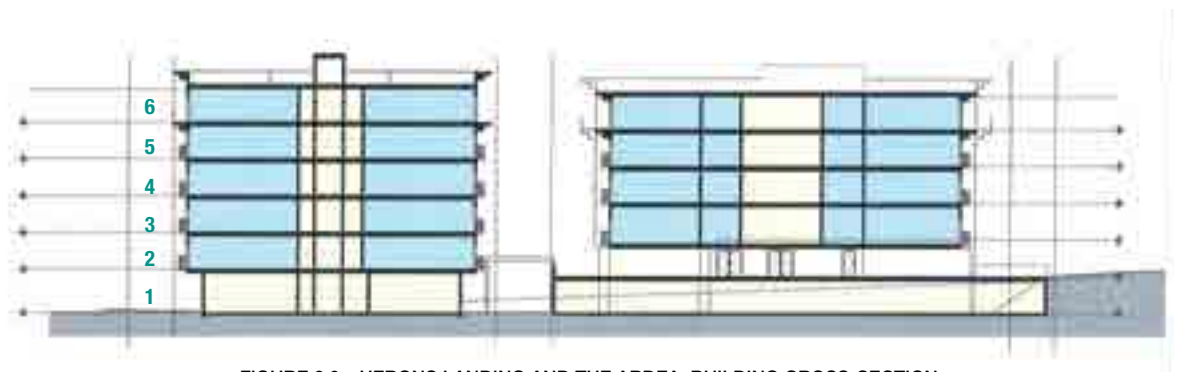

FIGURE 2.6 - HERONS LANDING AND THE ARDEA: BUILDING CROSS-SECTION

Hillcrest Village, Fort St. John, BC

Completion: Phase 1 – 2014

Hillcrest Village is located in the centre of Fort St. John, a city of 20,000 in the Peace River region of northeast BC. It provides much-needed rental accommodation for families working in the region's various resource industries (Figure 2.7).

With a total of 83 two- and three-bedroom suites, this two-phase project includes L-shaped four- and six-storey buildings (Figures 2.8 and 2.9) that together will frame a courtyard. Had four-storey construction been the only option, most of this space would have been required for surface parking.

The poor soil conditions on the site required that the building be as light as possible, while market conditions necessitated innovative and affordable solutions. The structures are built on a grid of parallel strand lumber (PSL) beams supported on concrete pile caps. There is no slab-on-grade, nor concrete toppings used on the upper floors, which instead use rigid insulation board and resilient floor finishes to control sound transmission. In addition to traditional light wood-frame and PSL beams, Hillcrest Village includes laminated strand lumber (LSL) spacer beams, and a nail-laminated timber (NLT) elevator shaft.



FIGURE 2.7 – HILLCREST VILLAGE PHASE 1 PROVIDES RENTAL ACCOMMODATION FOR FAMILIES WORKING IN THE RESOURCE INDUSTRY IN FORT ST. JOHN

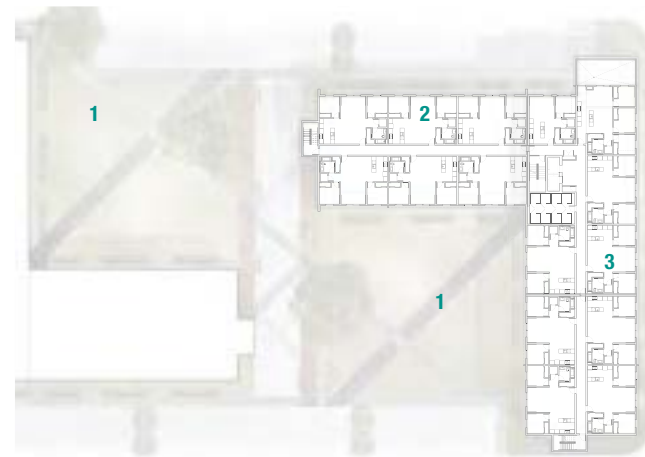

1. courtyard 2. four-storey wing 3. six-storey wing

FIGURE 2.8 – HILLCREST VILLAGE: PHASE 1 TYPICAL FLOOR PLAN



FIGURE 2.9 – HILLCREST VILLAGE: PHASE 1 BUILDING CROSS-SECTION

The Shore, North Vancouver, BC

Completion: 2017

This four-phase market condominium project is located close to the centre of North Vancouver (Figure 2.10). The site borders Mosquito Creek, with its hiking trails and nature walks, and many apartments have balconies or roof decks with views of either the North Shore mountains or Burrard Inlet. The buildings are five and six-storey wood-frame constructed on grade, or on top of a basement parking garage of concrete construction (Figures 2.11 and 2.12).

The complex is arranged around a central courtyard featuring multiple art installations, and has a total of 359 apartment units. Ranging in size from 480 sq. ft. to 1090 sq. ft., the apartments feature high-end finishes and fixtures, floor-to-ceiling windows, and in-floor radiant heating.

As a way to compare the impact of different approaches to construction on economy, efficiency, and performance, the Adera Development Corporation — which was both the developer and construction manager — used traditional site-construction methods and factory prefabrication on different phases of the project. Adera also explored different approaches to noise control and acquired first-hand knowledge of this aspect of building performance, for which little independent testing has been done to date.

All phases of The Shore are constructed using light wood-frame walls, engineered wood I-joist floors, and nail-laminated timber (NLT) elevator shafts, with engineered wood posts, beams, and headers where loading requirements dictate. The close proximity of the buildings led to the installation of dry sprinkler lines on the eaves of each completed phase to protect them from damage should a fire break out while the next phase was under construction.



FIGURE 2.10 – THE SHORE IS A FOUR-PHASE MARKET CONDOMINIUM PROJECT LOCATED ADJACENT TO MOSQUITO CREEK IN NORTH VANCOUVER

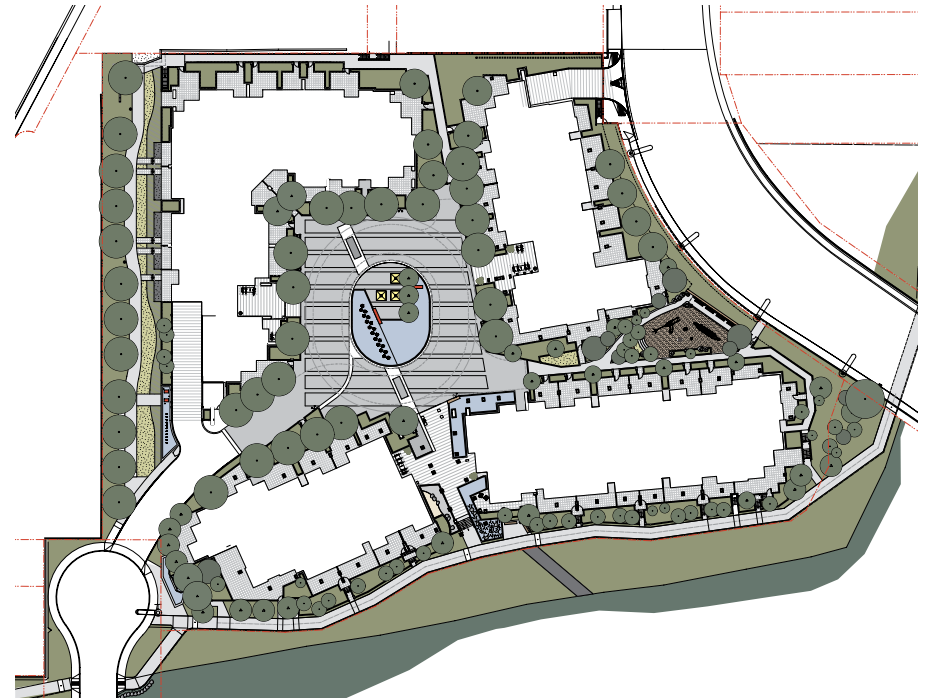

FIGURE 2.11 - THE SHORE: GROUND FLOOR AND LANDSCAPING PLAN

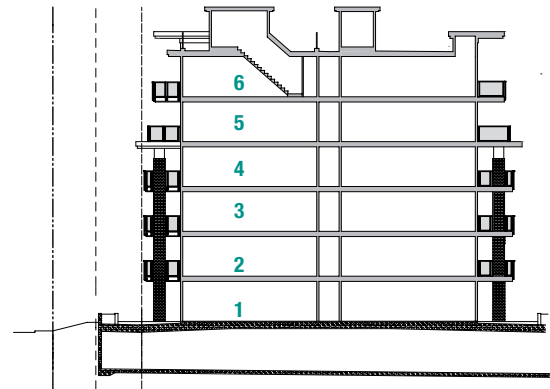

FIGURE 2.12 - THE SHORE: BUILDING 4 CROSS-SECTION

SFU Downtown Residence, Vancouver, BC

Completion: 2016

A precedent-setting contemporary example of a truly urban wood-frame building, this project is located on Victory Square, the historic civic centre of Downtown Vancouver (Figure 2.13). It provides much-needed accommodation for students enrolled in the various programs offered at the downtown campus of Simon Fraser University, just a few blocks away.

The building consists of four storeys of wood-frame construction, containing a total of 36 single- and 16 two-bedroom suites, above two storeys of concrete (Figures 2.14 and 2.15). The lower floors contain retail space at grade, with a collaborative learning area above. The project is built to the property line on all four sides, requiring a firewall between it and the adjacent building to the west.

The narrow (9-ft.-wide) student rooms facilitate the efficient application of light wood-frame construction, using conventional stud walls and wood I-joist floors. The firewall on the property line to the west and the elevator shaft above the second level are constructed using concrete masonry units (CMUs), while the street and lane elevations are finished with a brick masonry rainscreen cladding system.



FIGURE 2.13 – THE SFU DOWNTOWN RESIDENCE IS LOCATED ADJACENT TO VANCOUVER'S HISTORIC VICTORY SQUARE

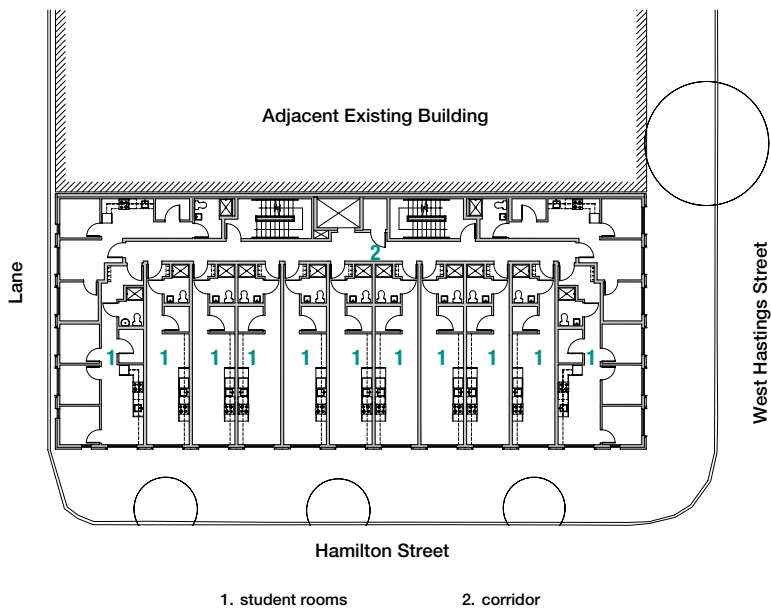
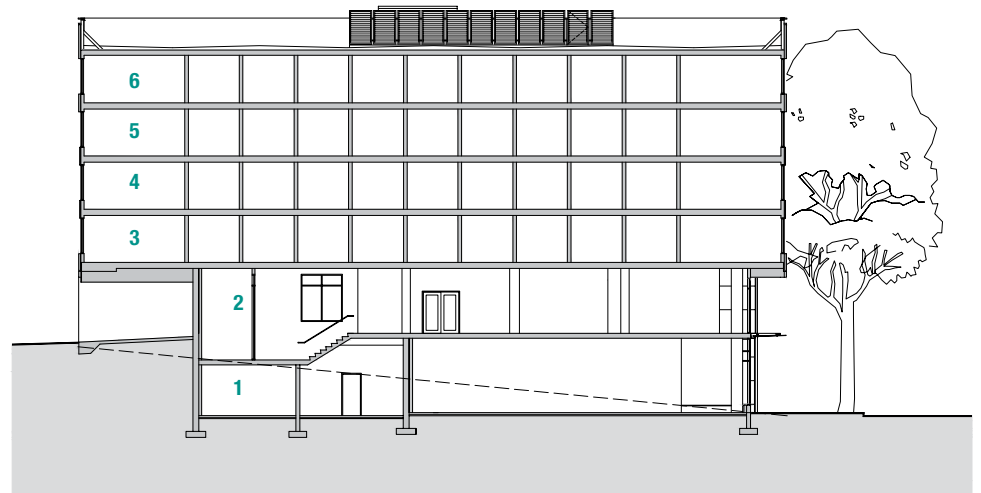

FIGURE 2.14 – SFU DOWNTOWN RESIDENCE: TYPICAL FLOOR PLAN



- | | | |
|--------------------|---------------------|---------------------|
| 1. retail | 3. student bedrooms | 5. student bedrooms |
| 2. student commons | 4. student bedrooms | 6. student bedrooms |

FIGURE 2.15 – SFU DOWNTOWN RESIDENCE: LONGITUDINAL BUILDING SECTION

3. DESIGN FOR INCREASED DEAD AND LIVE LOADS

“The design of plywood shear walls is driven mainly by the allowable deflection. In a major earthquake, a six-storey building could move up to eight inches laterally. That is why it is challenging to incorporate concrete block firewalls, as they cannot accommodate that kind of movement.”

Bruce Johnson – Managing Director, Read Jones Christoffersen Ltd.



FIGURE 3.1 – HILLCREST VILLAGE: A COMBINATION OF FIBRE CEMENT PANELS AND CEDAR SIDING IS USED TO MINIMIZE WEIGHT

From a structural engineer’s perspective, the major difference between four-storey and six-storey wood-frame buildings is that the latter are subject to significantly higher vertical and lateral loads. The self-weight of the building, which accounts for the majority of the vertical load, increases by half, while wind and seismic forces, which are the most common types of lateral loads found in BC, are effectively doubled.

Lateral Loads

The increased wind and seismic loads experienced by five- and six-storey buildings must be addressed by increasing the number, length, and capacity of shear walls.

Because these walls may have to be sheathed with oriented strand board (OSB) or plywood

on both sides (particularly on the lower floors), routing of services within them may be difficult or impossible. It is important that lengths and locations of shear walls are determined at the schematic design stage to ensure that plumbing and other services can be run without compromising the integrity of the walls.

The BCBC also requires that shear walls in five- and six-storey buildings be precisely aligned from one floor to the next so that there are no offsets in the load path. For this reason, Herons Landing, The Ardea, the SFU Downtown Residence, and Hillcrest Village all have identical apartment layouts on every floor, while in the other projects the layouts vary only slightly.

Lateral resistance must be provided in both directions (e.g. north-south and east-west) in a building aligned to the cardinal points of the compass. In a conventional layout with apartments arranged on either side of a central corridor, this will require shear walls to be provided both in the corridors and in the demising walls between suites. Adjacent apartments should be alternately “left-handed” and “right-handed” in plan (as is common practice to have plumbing stacks back-to-back) to maximize the length of the corridor walls between the entrance doors. At Hillcrest Village, where the apartment units are typically 30 ft. wide, approximately 40 percent of the corridor walls, and all the demising walls between suites, are designed as shear walls with sheathing on one side.

This standard approach could not be followed at Herons Landing and The Ardea, where the apartments are arranged around a central service core

with approximately equal numbers of units facing in each direction. This configuration enabled the structural engineer to achieve the required lateral resistance using only the demising walls between suites as shear walls (Figure 2.5).

It is worth noting that, while the forces imposed on a six-storey building are greater than those experienced by a four-storey building of the same construction, wood-frame construction is inherently light, and these forces are considerably less than those that would be experienced by a concrete building of similar size on the same site.

Often design teams decide to further reduce these forces by specifying a lightweight cladding material, particularly above the second floor. Examples include the panelized stucco used at Herons Landing and The Ardea, and the cement-based planks and brick veneer used at The Shore. Although working in a lower seismic zone, the design team for the Hillcrest Village project wanted to minimize the weight of the building because of poor soil conditions. In this case, they specified a combination of cement-based panels and fire-retardant-treated wood (Figure 3.1).

In the historic context of Vancouver’s Victory Square, the SFU Downtown Residence building breaks this general rule, being clad in a full-thickness brick rainscreen system (Figure 3.2).



FIGURE 3.2 – SFU DOWNTOWN RESIDENCE: THE FULL-WIDTH BRICK CLADDING EXTENDS FROM THE THIRD TO THE SIXTH FLOOR

Lateral Deflection

Being relatively light, wood buildings have less mass of inertia with which to resist the uplift forces and lateral deflections caused by wind and seismic loads.

In mid-rise wood-frame buildings, this resistance is provided by tie-down anchors. These are sectional threaded steel rods that run vertically through the walls of the building from the uppermost floor to the concrete slab, whether this be a slab-on-grade, the roof of a parking garage or a podium structure containing commercial or other accommodation. Single or multiple rods are typically located at, or close to, both ends of shear walls.

The tie-down anchors are typically installed in storey-height sections, connected with couplers and spring-loaded, in order to apply a continuous compressive force, even if shrinkage occurs in the structure. The base must be embedded in 24 inches of concrete, which requires coordination with the location of beams or slab bands. At Hillcrest Village (which is located in a low seismic

zone where wind forces govern lateral design) there are no concrete slabs, and grade beams occur only around the perimeter of the building. This means that the majority of tie-down anchors are secured to the interior grid of PSL grade beams using anchor rods drilled through the beams and held in place top and bottom with 4-in.-diameter steel bearing plates (Figures 3.3 and 3.4).

The combination of shear walls and tie-down anchors control, rather than eliminate, potential lateral deflection. Therefore, measures must be taken to ensure that, for example, firewalls separating adjacent building areas are designed to accommodate the anticipated movement. This is usually achieved by the use of proprietary jointing systems that include a rubber or other flexible gasket that spans the gap between building areas, and is anchored on either side by an aluminum profile. This was the typical detail used at The Shore, where fire doors were required in corridors that connected two adjacent building areas within the same phase (Figure 3.5).

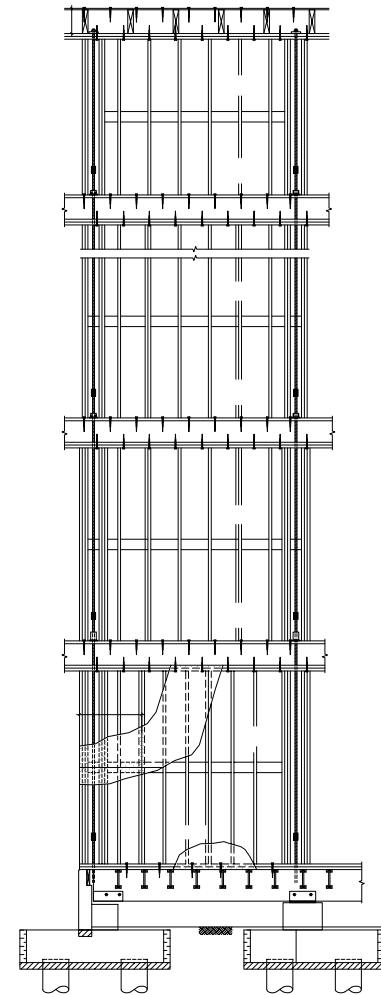
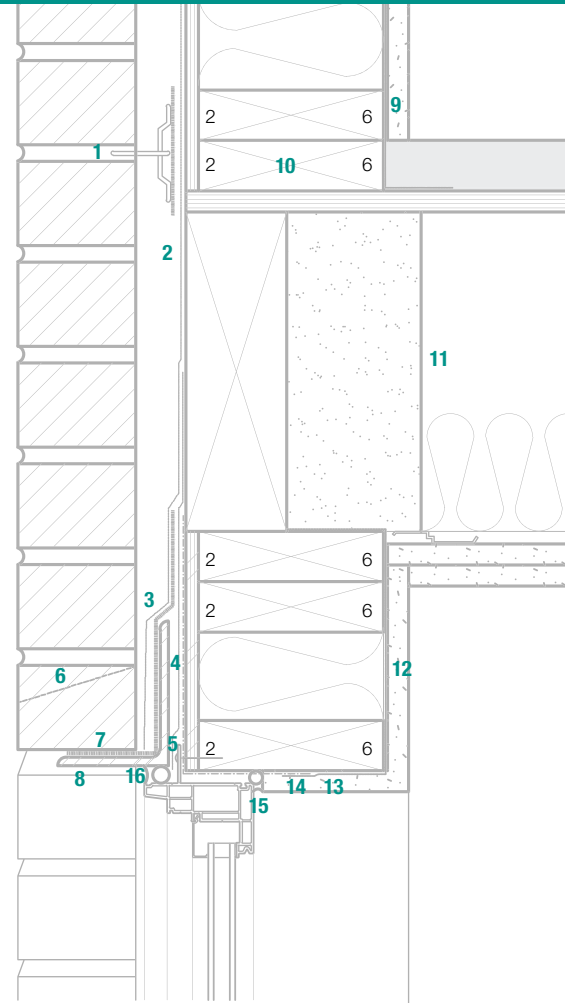

FIGURE 3.3 – HILLCREST VILLAGE:
DETAIL OF TIE-DOWN ANCHORS



1. proprietary firewall 2. roof of four-storey building 3. exterior wall of six-storey building

FIGURE 3.6 – HILLCREST VILLAGE: FIREWALL AND MOVEMENT JOINT BETWEEN FOUR- AND SIX-STOREY PORTIONS OF THE BUILDING



- 1. stainless steel brick tie (see struct. for spacing) on a piece of peel & stick
- 2. scl rim beam, see structural
- 3. lap commercial building wrap over shelf angle and peel & stick
- 4. continous piece of peel & stick under shelf angle
- 5. seal commercial building wrap to window flange with tuck tape
- 6. provide weep holes at 2'-0"o.c. w/ top edge 2" above angle
- 7. peel & stick over shelf angle terminated onto commercial building wrap above
- 8. hot dipped galvanized shelf angle, primed and painted to match colour of brick. supported at both ends by brick coursing. do not fasten to ply sheathing (refer to struct.)
- 9. 6 mil poly air/vapour barrier to turn down on floor
- 10. 2x6 p.t. perimeter bottom plate, typ.
- 11. r-20 spray foam insulation
- 12. 6 mil poly air/vapour barrier
- 13. wrap commercial building wrap starter strip into rough opening
- 14. seal poly air/vapour barrier to commercial building wrap with tuck tape
- 15. rod and caulk to fill gap between window frame and commercial building wrap
- 16. rod and caulk to fill gap

FIGURE 3.7 – SFU DOWNTOWN RESIDENCE: THE FULL-WIDTH BRICK CLADDING IS TIED BACK TO THE STRUCTURE AT EACH FLOOR LEVEL

As noted previously, one exception is the SFU Downtown Residence, where a full-brick masonry rainscreen wall extends to the top of the building. The brickwork is supported on a steel angle mounted to the third floor concrete slab and rises four storeys to the top of the building. It is self-supporting, with none of its weight being carried by the wood-frame wall behind it, but the masonry is tied back at every sixth course with masonry ties (Figure 3.7).

This particular use of masonry was made possible by the narrow plan and elongated geometry of the building (Figure 3.8). Because the long west wall is a reinforced CMU shear wall that experiences almost no drift under wind and seismic loads, the floor diaphragms attached to it are also very rigid. In combination with the closely spaced shear walls that run across the building between the studio units, this creates an exceptionally rigid “egg crate” structure that will experience little or no differential movement, even under significant lateral loads.

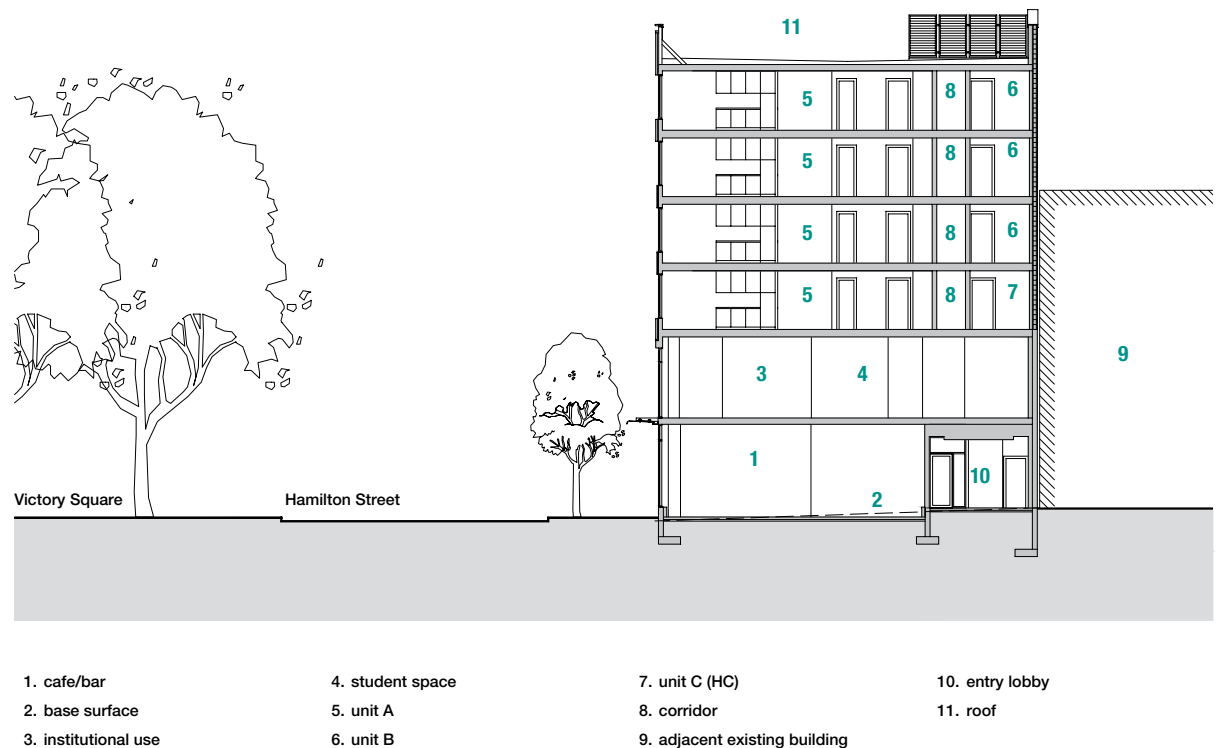

FIGURE 3.8 – SFU DOWNTOWN RESIDENCE: THE NARROW WIDTH OF THE BUILDING, WITH A CONTINUOUS SHEAR WALL ON ONE LONG SIDE, MAKES THE STRUCTURE EXTREMELY RIGID

Vertical Loads

The increased dead loads in five- and six-storey buildings can be resisted using a number of strategies, singly or in combination:

- Conventional studs can be nail-laminated together to form bearing posts
- Higher strength material, such as Douglas fir, can be specified
- Studs can be more closely spaced
- Engineered wood posts can be used where greater strength is needed

These strategies are generally necessary only on the lower floors of the building. At Sail, for example, the structural engineer specified laminated Douglas fir studs on the first four floors, and spruce-pine-fir (SPF) on levels five and six (Figure 3.9).

Since their introduction in 2013, the increased energy conservation requirements for Part 3 buildings of four storeys or more have resulted in the adoption of 2x6 framing as standard for external walls. In many projects, 2x6 internal walls are also used on the lower floors to meet the increased structural load requirements. Demising walls between suites either consist of staggered 2x4 studs between 2x6 sill and header plates; or two separate 2x4 walls (for more detail, see Section 5: Fire Safety and Noise Control). In either case, the load-carrying capacity of these walls is equal to or greater than that of a standard 2x6 wall.



FIGURE 3.9 – SAIL: THE LOWER FLOORS USE DOUGLAS FIR STUDS FOR STRENGTH; THE UPPER FLOORS USE SPRUCE/PINE/FIR (SPF)

4. CONTROLLING SHRINKAGE AND DIFFERENTIAL MOVEMENT

“In order to minimize shrinkage, you have to use engineered floor joists and kiln dried top and bottom plates.

These measures ensure that the shrinkage in a six-storey building is about the same as it used to be when we were building four storeys.”

Dale Staples – Principal, Integra Architecture

Wood is a naturally hygroscopic material, meaning that it absorbs and releases moisture in order to maintain a state of equilibrium with its surroundings. During this process, wood members will expand or contract at a predictable rate.

The cellular structure of wood can be likened to that of a bunch of drinking straws. Liquid water is found in both the tubes of the straws (free or capillary moisture) and in the walls of the straws themselves (bound moisture). The release of free moisture does not cause shrinkage but that of bound moisture does.

When a tree is felled, it is likely that its fibres (the walls of the straws) will be saturated with moisture, and this moisture will weigh approximately 28 percent of the dry weight of the wood in which it is entrained. When wood members are installed in a building, and that building is enclosed and conditioned, the wood will continue to release moisture until it achieves equilibrium with its surroundings. In BC, this equilibrium moisture content (EMC) will vary between eight percent and 12 percent, depending on location and time of year.

Shrinkage

The release of bound moisture results in shrinkage of approximately one percent for every five percent decrease in moisture content (MC) perpendicular-to-grain, and approximately 2.5 percent of this value parallel-to-grain. In the context of mid-rise wood-frame construction, shrinkage parallel-to-grain is negligible and its effect may be ignored.

However, for every four inches of material, shrinkage perpendicular-to-grain may be as much as 5/32 in. between the “green” MC and the in-service EMC. It has always been desirable to use “dry” wood (with a MC of 19 percent or less) in frame construction, but with five- and six-storey buildings, the use of dry lumber or engineered wood is critical to minimize the accumulated shrinkage, which otherwise could be as much as three or four inches over the height of the building.

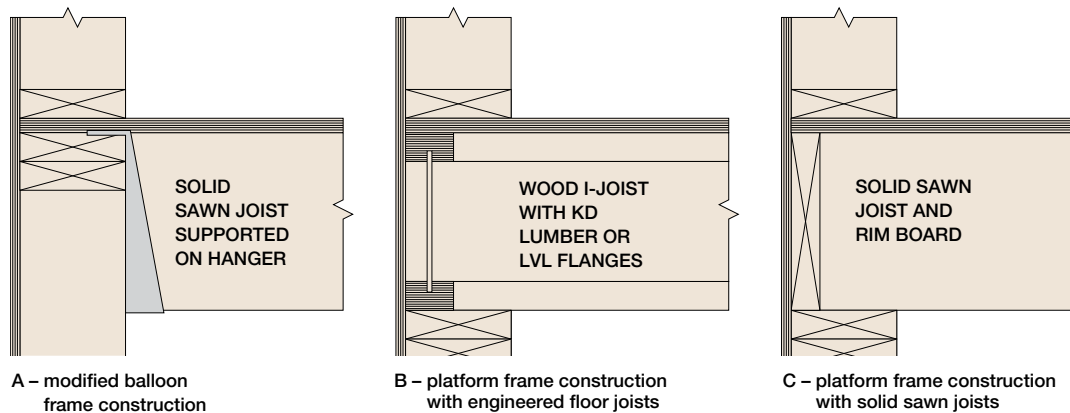

FIGURE 4.1 – OPTIONS FOR FLOOR-TO-WALL CONNECTION DETAILS

Most of the shrinkage will occur in the top plates and sill plates, and potentially in the floor joists, depending on how these are framed into the walls, and whether they are solid-sawn lumber material or engineered wood I-joists (Figure 4.1). Wood I-joists, which may have plywood or OSB webs and laminated veneer lumber (LVL) flanges, are supplied at a MC equal or close to the anticipated in-service EMC, and have become the most popular floor system for five- and six-storey construction.

However, at Hillcrest Village, where economy was of paramount importance, it was necessary to minimize the use of more expensive engineered wood components, and substitute as much solid-sawn lumber as possible. While 2x4 and 2x6 material is readily available at a MC of 12 or 15 percent, the 2x10 material used for joists must be special ordered. To avoid this additional cost, it was necessary for the design team to develop

a detail that would enable them to use solid-sawn lumber joists with a higher moisture content.

Floor panels were prefabricated on site using 2x10 lumber, then lowered into place by crane and bolted to laminated strand lumber (LSL) spacer beams in a modified version of balloon frame construction (Figures 4.2 and 4.3). These LSL beams are 9 1/2 in. deep (equal to the depth of the floor joists), and 2 3/4 in. wide. They were installed in pairs on top of the bearing walls, and topped with a plywood shim before the next storey was constructed. By using an engineered wood member in this location, the solid-sawn lumber material (which is subject to considerable shrinkage) is kept out of the vertical load path of the wall structure.

To accommodate the anticipated shrinkage, the upper surface of the floor joists was set approximately 3/16 in. above the top of the LSL beams,

so that as the joists reached their EMC, they would be flush with the supporting beams. The negligible shrinkage in the LSL meant that the effects of shrinkage were confined to individual floors, rather than accumulating up the building. Twelve months after the building was completed, the contractor conducted an inspection and found that very little shrinkage (other than that planned for) had occurred anywhere in the structure.

Approximate shrinkage values can be calculated based on the specification of the lumber used.

- Lumber that is surfaced green, commonly stamped S-GRN, has a MC greater than 19 percent at the time of manufacture.
- Common dry lumber, including surfaced dry (S-DRY), kiln dried (KD) and kiln dried and heat treated (KD HT), have a maximum MC of 19 percent at the time of manufacture.
- MC 15 or KD 15 has a maximum MC of 15 percent at the time of manufacture.

The MC 15 specification is becoming more common and was used by the design team for the Sail project for all the top and sill plates on the first four floors of the building. Four years after completion, Phase 1 of Sail has experienced no more shrinkage than would have been expected in a four-storey building. Through a similar attention to specification and detailing, other more recent projects appear to be heading for similar outcomes.

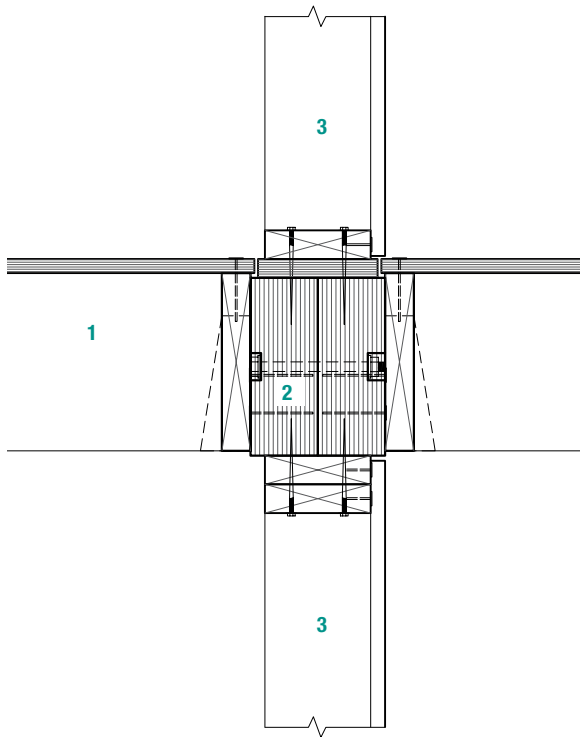

- 1. prefabricated floor panel
- 2. LSL spacer beams
- 3. loadbearing frame wall

FIGURE 4.3 – HILLCREST VILLAGE: FLOOR PANELS ARE SECURED TO LAMINATED STRAND LUMBER (LSL) SPACER BEAMS BUILT INTO THE WALLS



FIGURE 4.2 – HILLCREST VILLAGE: ON-SITE PREFABRICATION OF FLOOR PANELS

Differential Movement

Once it has reached its in-service EMC, wood is relatively stable. By contrast, concrete, steel, masonry, and other materials continue to expand and contract with changes in temperature. Where the wood structure or wood finishes meet another material (including plumbing and other service risers), there can be the potential for dif-

ferential movement between them. This is most likely to occur between wood floors and elevator shafts or firewalls constructed of cast-in-place concrete or concrete masonry. For this reason, most design teams now prefer to use proprietary gypsum firewalls and nail-laminated timber (NLT) elevator shafts.

In the case of Hillcrest Village, the NLT elevator shafts were “stick-built” on site, just as a conventional frame wall might be. The shaft was erected one floor at a time, each storey height wall element being built on top of a 5 1/2 in.-wide and 9 1/2 in.-deep PSL beam, exactly corresponding to the LSL beams to which the floor panels are attached (Figures 4.4 and 4.5).

This detail ensured that, should any shrinkage occur, it would be consistent within each floor level, and evenly spread throughout the building. Despite the advantages of NLT elevator shafts, the use of concrete or other noncombustible construction materials has sometimes been a requirement of municipal authorities. Provincial legislation recently introduced in British Columbia has removed this discretionary power from municipalities in relation to buildings that are permitted under BCBC to be of combustible construction. However, the client or structural engineer may prefer to use cast-in-place concrete or CMU construction for elevator shafts, and adjustable elevator thresholds or other special details may be required. In the case of the SFU Downtown Residence (where a concrete masonry elevator shaft was chosen for reasons described in Section 5, below) shrinkage of the wood-frame elements was strictly controlled by careful specification and detailing, and only a standard threshold detail was required where the wood and CMU structures meet.



FIGURE 4.4 – HILLCREST VILLAGE: INTERIOR VIEW OF NAIL-LAMINATED TIMBER (NLT) ELEVATOR SHAFT

One initial concern with NLT elevator shafts was the possibility of horizontal displacement or distortion that might result in misalignment of the elevator guideways, and hence intermittent stoppages and an increased number of service calls. With the use of engineered wood products to minimize shrinkage, attention to the vertical alignment of the shaft during construction, and increased familiarity on the part of elevator manufacturers, these concerns have been alleviated. None of the buildings included in this practice guide have experienced any undue differential movement of this kind.



FIGURE 4.5 – HILLCREST VILLAGE: CLOSE UP VIEW OF NLT ELEVATOR SHAFT

5. FIRE SAFETY AND NOISE CONTROL

“We are finding that our clients are much more concerned about noise control than they used to be. We pay careful attention to bathroom and kitchen planning to avoid plumbing in the walls between suites, and carefully seal the junctions at floors, walls and ceilings, as well as at any penetrations.”

Dale Staples – Principal, Integra Architecture

Building codes define the minimum standards for fire and life safety, thermal insulation, noise control, and other aspects of performance that any structure of a given size, height, and occupancy must meet. Thus, whatever the primary construction material used, these performance standards are the same.

Fire Safety

When the 2009 changes to the BCBC increased the permissible height for wood residential buildings, they also applied several of the existing requirements for residential buildings of noncombustible construction over four storeys, including:

Mid-rise buildings more than four storeys must be fully sprinklered to the National Fire Protection Association (NFPA) 13 standard.



FIGURE 5.1 – SAIL: EXTERIOR WOOD STRUCTURES SUCH AS ENTRANCE CANOPIES, MUST BE OF HEAVY TIMBER CONSTRUCTION



FIGURE 5.2 – THE SHORE: EXTERIOR WOOD STRUCTURES SUCH AS ENTRANCE CANOPIES, MUST BE OF HEAVY TIMBER CONSTRUCTION

In general, exterior cladding must be noncombustible.

However, the 2009 changes do permit the use of fire-retardant-treated wood cladding on mid-rise wood buildings (as previously noted at Hillcrest Village). The definition of “exterior cladding” in the code refers only to the outer layer of a wall assembly, and not to trims and soffits, which may still be of untreated wood. Wood used in other exterior applications, such as porches and canopies, must conform to the requirements for heavy timber construction (Figures 5.1 and 5.2).

Where NLT elevator shafts are used, the wood surfaces within the shaft must be sheathed in fire-retardant-treated plywood, gypsum wallboard or other material with a flame-spread rating of 25 or less, to meet the flame-spread requirements for vertical service spaces. If the height of the building exceeds 18 metres from grade to the floor level of the uppermost storey, it will be considered a “high building” under the BCBC. In such a case, pressurization of the elevator shafts will be required. This will apply to both combustible and noncombustible shafts. Within the common areas of the building, the assembly fire-resistance ratings and interior finish flame-spread ratings are the same as those required for four-storey combustible construction. In most cases, stair shafts are of light wood-frame construction (Figure 5.3) protected by two layers of Type-X drywall.



FIGURE 5.3 – HILLCREST VILLAGE: AS IS TYPICAL IN MID-RISE CONSTRUCTION, STAIR WELLS ARE CONSTRUCTED WITH LIGHT WOOD-FRAME ELEMENTS

With the exception of the SFU Downtown Residence, all the featured projects use proprietary firewalls of one kind or another. These systems sandwich a gypsum fire barrier between two wood-frame walls, each of which can continue to support the gypsum system should fire compromise the integrity of the wood-frame wall on the other side (Figure 5.4 and refer back to Figures 3.5 and 3.6).

On the SFU Downtown Residence, the four-storey reinforced concrete masonry firewall on the west side of the building, which rises from the concrete podium structure, runs the full 160-ft. length of the property line. The wall was constructed one floor ahead of the wood-frame structure of the building itself, and is both a fire-resistance-rated (FRR) wall and a load-bearing wall. Steel angles at each floor level pick up the ends of the wood I-joists that span the corridor that runs the length of the wall. This wall forms the back of the elevator shaft, which was also constructed with CMUs for simplicity and economy.

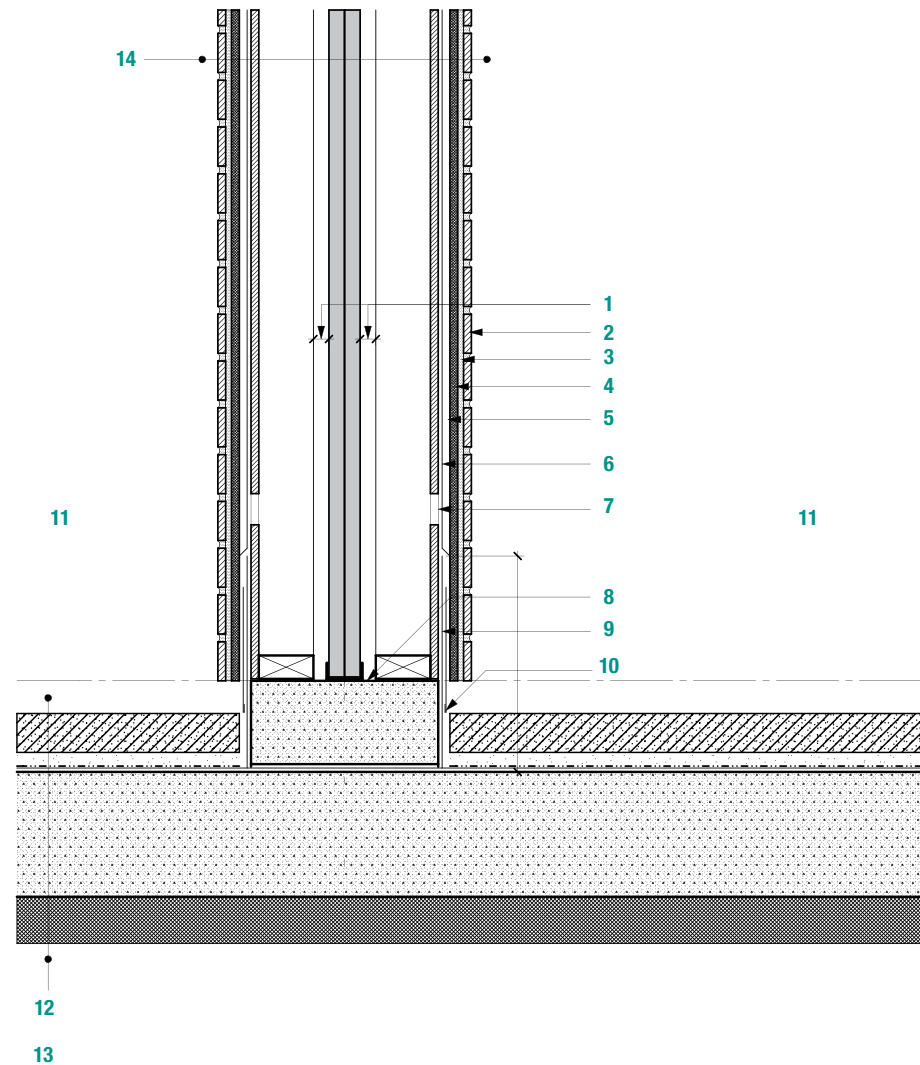

- | | | | |
|---|---|--|--------------------|
| 1. 1" airspace | 6. 'tyvek' moisture barrier continuous over joists and sheathing – applied shingle style – min. 4" horizontal laps & min. 12" vertical laps | 8. concrete wall base – see struc. dwgs. | 11. patio |
| 2. 1/2" brick veneer | 7. provide 2"Ø screened vent holes @ every stud space | 9. extend waterproof membrane min. 1'-0" above column base | 12. floor type f2b |
| 3. 3/8" scratch coat | | 10. 26 ga. prefinished steel flashing – slate grey | 13. parkade |
| 4. 1/2" cement backer board | | | 14. wall type w11 |
| 5. 3/4" x 1 1/2" cca pressure treated plywood strapping @ max. 16" o.c. | | | |

FIGURE 5.4 – THE SHORE: TYPICAL PROPRIETARY FIREWALL CONSTRUCTION

At Hillcrest Village, where four- and six-storey portions of the building meet, the firewall extends beyond the roof of the four-storey building to the top of the six-storey building. This two-storey portion was designed to be self-supporting should the six-storey building collapse in a fire. It contains no openings, other than intake and exhaust ducts that are protected by fire dampers (Figure 5.5). The other approach considered, which would have permitted operable windows in the wall for the taller building, was to make the roof of the lower building a fire-rated assembly. This option was rejected on grounds of cost.

On this project, additional firewalls were added to limit the building area on either side and so reduce the size of any potential fire. Although this was not required by code, it was considered a necessary precaution because of the limited water supply available for firefighting in Fort St. John.

Noise Control

In regard to the acoustic performance of buildings, the code concerns itself largely with the control of transmission of airborne noise generated within multi-unit residential buildings. Reducing the sound transmission through the horizontal (floor/ceiling) and vertical (wall) separations between suites is critical in multi-family residential construction. The majority of complaints from tenants of rental buildings relate to issues of unwanted noise, as do the majority of new home warranty program complaints from owners of units in multi-family residential buildings.

Sound is propagated either through the air (airborne sound), or through building elements (structure-borne sound). Noise reduction strategies for both types of sound propagation begin with maximizing the mass of the building element between the source and the receiver, so that more of the sound energy is absorbed as a result of the increased inertia of the element. This required mass may be achieved by using a concrete topping and/or a suspended drywall ceiling in the case of floor/ceiling assemblies; or, by using multiple layers of drywall on one or both sides of a demising wall between suites.



FIGURE 5.5 – SFU DOWNTOWN RESIDENCE: ACOUSTIC PARTITIONS BETWEEN SUITES ARE CONSTRUCTED USING STAGGERED STUDS

Beyond the considerations of mass, the strategies for controlling airborne and structure-borne sound diverge. To reduce airborne sound transmission, acoustic insulation (e.g. mineral wool, fibreglass or cellulose) can be placed within the ceiling or wall cavities. The labyrinthine internal structure of such insulation reflects sound energy at every turn, transforming noise into heat.

To reduce structure-borne sound, the main concern is to create discontinuity along the direct path of travel (e.g. from one side of a wall or floor assembly to the other). For walls, this can be achieved using staggered 2x4 studs mounted between 2x6 sill and top plates (Figure 5.5) or by constructing two separate 2x4 walls with a 1-in. gap between them. Further discontinuity can be achieved by fastening the drywall on resilient channels. For floor/ceiling assemblies, discontinuity can be achieved by installing a suspended ceiling beneath the floor structure, or if space is limited, by mounting the drywall ceiling to the underside of the joists using resilient channels.

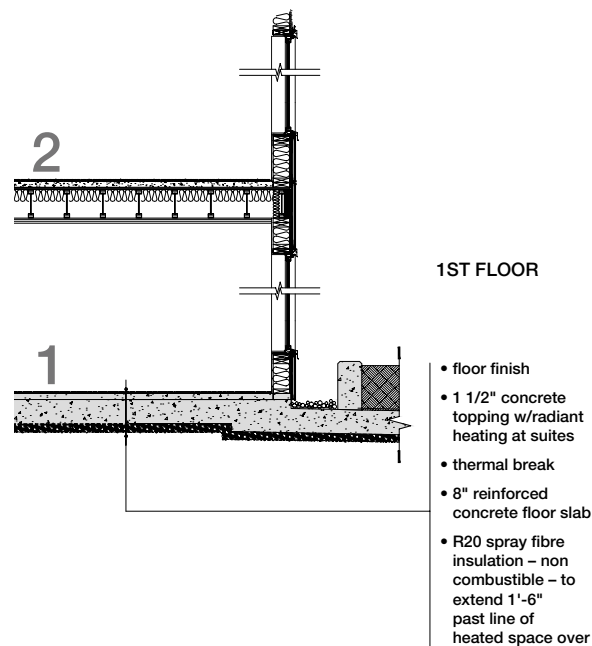

FIGURE 5.6 – SAIL: THE CONCRETE FLOOR TOPPING INCLUDES PIPING FOR THE RADIANT HEATING SYSTEM, AS WELL AS IMPROVING ACOUSTIC ISOLATION BETWEEN SUITES

Attention must also be paid to the continuity of these sound barriers to avoid the phenomenon of “flanking sound”. This can be seen as analogous to water leaking from an otherwise perfect bucket through a tiny hole. The junctions between walls, floors, and ceilings, and penetrations for pipes, ducts, and other services must be carefully and completely sealed. These potential weak spots can be minimized through careful planning: for example, by organizing bathrooms and kitchens so that no services run in the demising walls between suites.

The choice of noise reduction strategies will depend on budget and market expectations, which in turn may be, in part, a function of whether the project is a rental or condominium building. The choice of using a concrete topping for sound transmission control may also depend on whether a hydronic radiant heating system is being installed, in which case a minimum topping thickness of 1 3/4 in. is required. This was the case at The Shore, where the City of North Vancouver requires major developments to tie into its district energy system, and thus install hydronic heating. A radiant floor system was also used at Sail (Figure 5.6).

At Hillcrest Village, no concrete toppings were used, partly because the soil conditions required the building to be as light as possible, and partly for reasons of cost. Instead, an acoustic mat was installed below the resilient floor finish, and the ceilings were constructed using two layers of drywall mounted on resilient channels attached to the underside of the 2x10 floor joists (Figure 5.7).

As developer of Sail, The Shore and many similar projects, the Adera Development Corporation has been searching for the optimal balance between performance and price point. Adera has experimented with different floor/ceiling and wall configurations, to find the combination that meets or beats the performance of concrete with regard to acoustics. Phase 4 of The Shore may well achieve this goal, although the precise details of the system are not being disclosed.

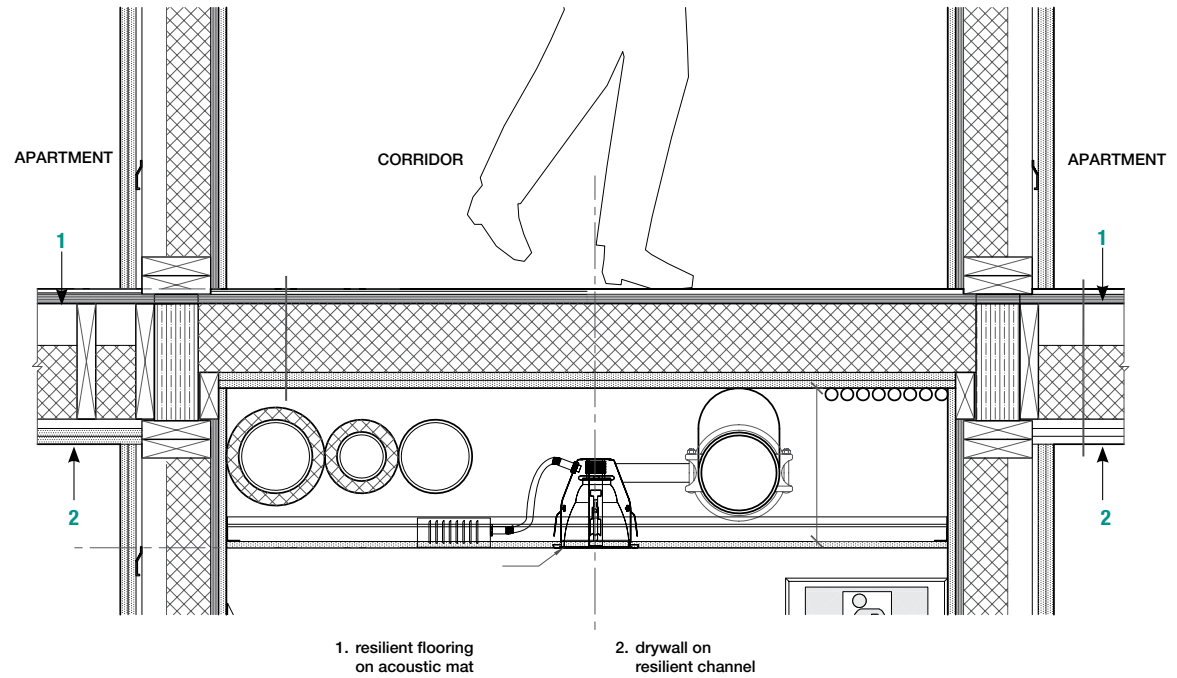

FIGURE 5.7 – HILLCREST VILLAGE: TO MINIMIZE BOTH WEIGHT AND COST, THE PROJECT USES RESILIENT FLOORING AND A DRYWALL CEILING RATHER THAN CONCRETE TOPPING FOR ACOUSTIC ISOLATION

6. BUILDING ENVELOPE CONSIDERATIONS

“In addition to insulation in the stud cavities, continuous exterior insulation was required to meet current code standards. We typically recommend insulation to be all exterior for much better efficiency and insulative continuity, but considering the owner’s requirements for this project we went with a split assembly in order to minimize the overall wall thickness, and maximize the useable floor area.”

Jordan Van Dyck – Associate, MGA | Michael Green Architecture

All of the projects featured in this practice guide received building permits before the BCBC introduced new insulation standards in December 2015. With the exception of Hillcrest Village, which is in a more extreme climate zone than those in the Lower Mainland and Vancouver Island, they achieved the required insulation levels for the walls using only cavity insulation. From inside to outside, the typical wall construction is: interior drywall finish; polyethylene vapour barrier; fibre-glass or mineral wool insulation in cavity; exterior plywood or OSB sheathing; vapour permeable air barrier; rainscreen cavity; exterior cladding (Figures 6.1 and 6.2).

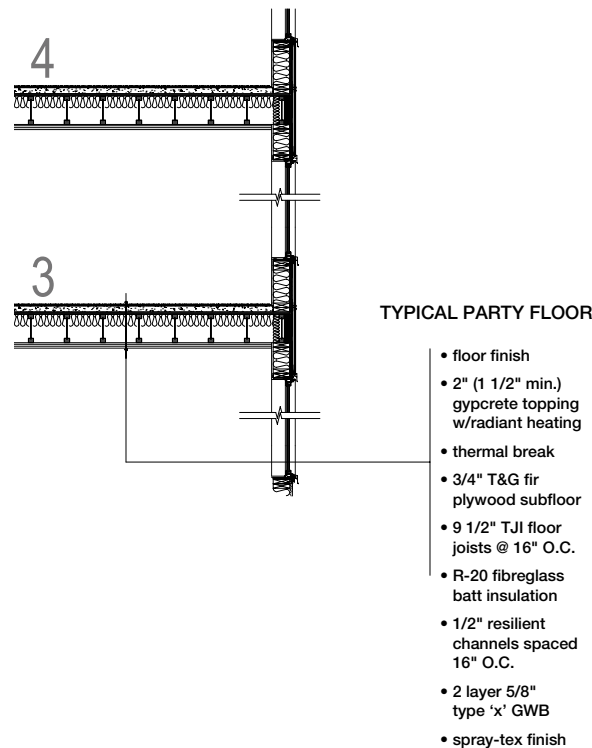

FIGURE 6.1 – SAIL: TYPICAL WALL SECTION

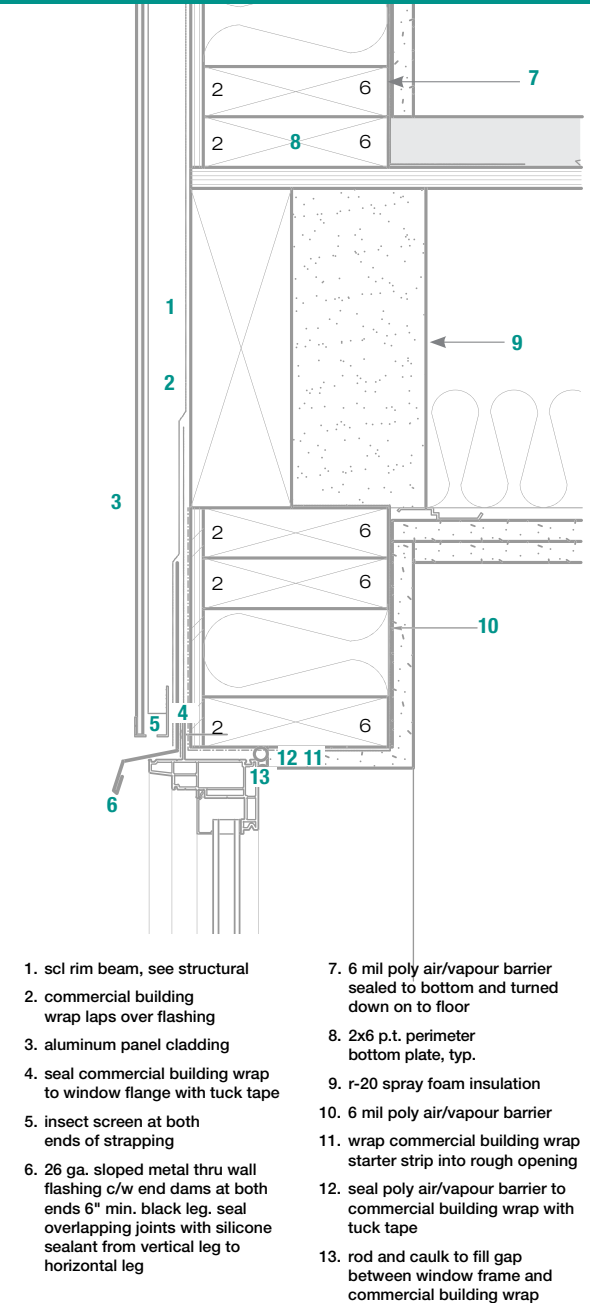
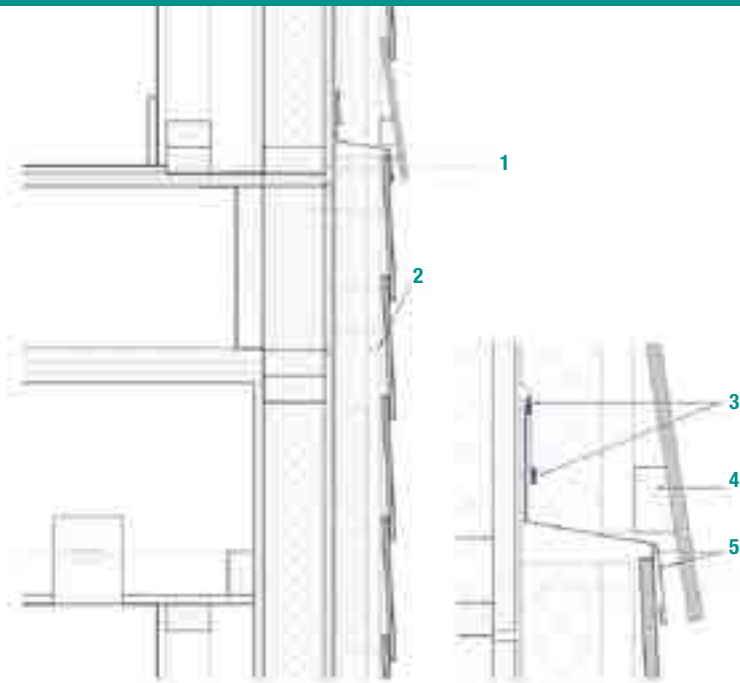
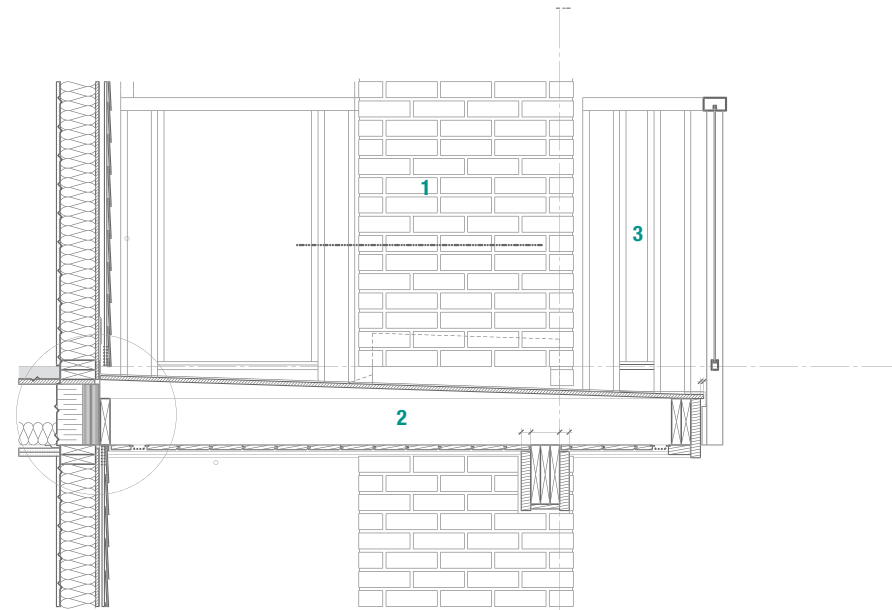

FIGURE 6.2 – SFU DOWNTOWN RESIDENCE: TYPICAL WALL SECTION



- | | |
|---|------------------|
| 1. levels 3 and 5 finished floor | 3. tape |
| 2. provide shrinkage gap at vertical strapping to correspond with location at sheathing as required | 4. blocking |
| | 5. insect screen |

FIGURE 6.3 – HILLCREST VILLAGE: COMBINED CAVITY AND EXTERIOR INSULATION (LEFT); CLADDING FASTENED THROUGH RIGID EXTERIOR INSULATION DIRECTLY INTO STUDS (RIGHT)



- | | | |
|--|---------------------------------|--------------------|
| 1. masonry clad wood post supporting balcony | 2. wood-frame balcony structure | 3. balcony railing |
|--|---------------------------------|--------------------|

FIGURE 6.4 – THE SHORE: SECTION THROUGH EXTERIOR BALCONY

This is a wall assembly with which most developers and contractors are familiar, and that has a proven performance and a known cost. However, Hillcrest Village provides an example of the split insulation system that may well be required for buildings to meet the new energy conservation standards. In addition to mineral wool cavity insulation, the project includes 3 in. semi-rigid mineral wool insulation installed on the outside of the plywood sheathing. This is then covered with the air barrier, and strapping and exterior cladding

installed. The insulation is sufficiently rigid so that it will support the strapping and cladding without compressing. The strapping is screwed directly into the studs, thus avoiding any thermal bridges across the insulation layers (Figure 6.3).

The same level of thermal performance could also have been achieved using a thicker layer of exterior insulation, eliminating cavity insulation altogether. However, the split system was chosen as it minimized the wall thickness, and provided

the maximum internal floor area within the allowable floor space ratio.

As energy standards become more stringent, and greater thicknesses of insulation are required, different types of insulation may be used in combination. This will require architects to consider the composition of wall assemblies even more carefully to ensure that the vapour permeance of the layers increases from inside to outside, enabling vapour to pass through the wall without causing condensation.

It will also be necessary to devise details that will eliminate thermal bridging through the envelope altogether. One place where this is already being considered is in the design of exterior balconies. The traditional detail, as used in Herons Landing and The Ardea, is to install a dropped beam in the exterior wall and have a series of header joists cantilever over it to support the balcony. While wood is a poor conductor of heat, this nonetheless results in multiple penetrations through the envelope, potentially compromising its performance.

An alternative approach is that used at The Shore, where the balconies are simply supported. Pairs of vertical posts are erected five feet away from the building, and support horizontal beams at each floor level. From this beam, joists are framed back to the building where they are attached to a ledger. The ledger is screwed through the plywood sheathing directly into the studs, eliminating thermal bridges (Figure 6.4). To integrate these balconies visually with the buildings, the vertical structure was clad in masonry (Figure 6.5) – refer also to the building section (Figure 2.12). At Hillcrest Village, instead of projecting balconies, railing is installed at the sliding patio doors in each suite, so that the sliding door may be opened completely. This solution is commonly referred to as a “French balcony” (Figure 6.6).



FIGURE 6.5 – THE SHORE: BALCONY SUPPORTS CLAD IN MASONRY



FIGURE 6.6 – HILLCREST VILLAGE: NO PROJECTING BALCONIES

7. CONSTRUCTION PRACTICES

“On The Shore, the developer wanted to compare the speed of prefabrication with that of traditional stick framing, so we used different approaches on different phases of the project. When we had an experienced framing crew, we found that work proceeded as quickly as when prefabrication was used.”

Dale Staples – Principal, Integra Architecture

When six-storey wood-frame construction was re-introduced to British Columbia following the code changes of 2009, it was widely believed that prefabrication held the key to the increased precision required for these taller buildings. Concerns were also raised about weather protection, as a six-storey building takes approximately 50 percent longer to construct than a four-storey version using the same techniques. Lastly, while a completed wood-frame building is statistically just as safe as a noncombustible one, it was understood that special measures might be required to protect wood structures from fire while under construction.

On-site and Off-site Prefabrication

Although prefabrication, either on-site or off-site, is more prevalent in six-storey construction than in four-storey construction, it is by no means universal. Of the five projects featured in this guide, only Hillcrest Village employed off-site prefabrication, and this was only for the walls (Figure 7.1). The floors for Hillcrest were prefabricated on-site (Figure 7.2) as were the walls for Sail, Herons Landing and The Ardea. At the SFU Downtown Residence, all framing was done on site (Figure 7.3).

The Shore presents the most interesting case study, because the Adera Development Corporation chose to prefabricate Phase 1 on site and to stick-build Phase 2. The aim was to determine whether one method was demonstrably superior to the other in terms of economy, speed, and precision. The results were so close that Adera now considers that this decision should be left up to the framing subcontractor. However, architect Dale Staples of Integra Architecture believes that, as the code requirements and market expectations for performance and durability increase, prefabrication will provide the necessary assurance of quality and consistency.



FIGURE 7.1 – HILLCREST VILLAGE: FACTORY PREFABRICATION OF WOOD-FRAME WALLS



FIGURE 7.2 – HILLCREST VILLAGE: SITE PREFABRICATION OF FLOOR PANELS

The storey-height walls used at Hillcrest Village were prefabricated by Mitsui Homes in Langley, BC, to a tolerance of +/- 1/8 in. At Sail, similar results were achieved by different means. Here, the walls were prefabricated under cover on site. As each storey was completed, the top-of-wall elevation was surveyed and checked against the datum on the construction drawings. Any errors were compensated for by adjusting the height of the walls on the next storey, so there was no possibility of errors accumulating as work progressed. Prefabrication proceeded one or two days ahead of demand on site, with quality control being the responsibility of the senior site carpenter. In this case, prefabrication was employed for reasons of speed and economy, rather than for increased precision.



**FIGURE 7.3 – SFU DOWNTOWN RESIDENCE:
ALL FRAMING FOR THIS PROJECT WAS DONE ON SITE**

At Hillcrest Village, the installation of the prefabricated components proceeded so quickly that maintaining the correct sequence of other trades proved to be a challenge. While this disruption might initially seem to be a disadvantage, it has been overcome on other large wood projects through early consultation with — and commitments from — all the trades. On projects such as Brock Commons Tallwood House, the recently completed student residence building at the University of British Columbia, this approach has resulted in much shorter construction times and improved quality. It could greatly reduce the soft costs for developers in the private sector.

Prefabrication also offers other advantages on larger projects. It optimizes material use, minimizes waste and centralizes recycling, permits just-in-time delivery of components to sites with limited access or storage space, and also lets framing begin in the factory while concrete work is still happening on site.

Weather and Moisture Protection

Longer construction times increase the risk of materials getting wet before the building is enclosed. In addition, the greater number of laminated or built-up solid-sawn studs required to carry the increased weight of the building further exacerbates the issue. In the event that these grouped studs are exposed to water, they tend to retain it longer than do single studs. There are many strategies that can be employed to manage weather and moisture during construction. For example, to reduce dampness of wood sill plates, creating a concrete up-stand around the perimeter of the building at the lowest level raises the sill plates above the level of any water that may pond on the slab. This strategy was successfully used at Sail.

It is common practice to monitor the MC of the framing lumber, and if necessary, this must be brought down to less than 19 percent before the finishes are installed.

Fire Safety for Buildings Under Construction

The first six-storey mid-rise wood-frame residential building constructed in BC was the Remy project in Richmond, which was unexpectedly destroyed by fire while under construction in 2010. It was subsequently rebuilt, and since then, more than 100 five- and six-storey wood-frame residential buildings have been successfully completed throughout the province. The Remy construction site fire did not negatively impact the uptake of mid-rise wood-frame construction as a whole, but it did prompt the creation of a construction safety protocol that is now being adopted either formally or informally by most developers and municipal fire authorities.

“The Remy fire ... prompted the creation of a construction safety protocol that is now being adopted ...”

Developed by the Adera Development Corporation for the Sail project, the protocol includes several recommendations relating to fire safety during construction, including:

- Running water should be available on site for firefighting throughout the construction period
- Drywall should be installed from the ground floor up rather than the reverse, which has always been the standard practice
- Hot trades, such as welding and torch-on roofing, should be carefully supervised, or eliminated altogether
- In multi-phase projects where buildings are in close proximity, a dry sprinkler system should be installed in the eaves soffits of completed structures to prevent the spread of any fire that might start while the adjacent phase is under construction

Site Logistics

Six-storey wood-frame buildings present a similar level of complexity to that of traditional high-rise construction. Most projects will require the use of a crane, particularly if there is prefabrication involved or if there are multiple phases to be built (Figure 7.4).

Construction managers must exercise a high degree of control, and sub-trades must meet required schedule deadlines to ensure the efficient use of expensive crane time, and to prevent the backing up of sub-trade work if, for example, installation of prefabricated components proceeds at a rapid pace.



FIGURE 7.4 – SAIL: A CRANE WAS POSITIONED BETWEEN THE PHASE 1 AND PHASE 2 BUILDINGS

8. ENVIRONMENTAL BENEFITS OF WOOD CONSTRUCTION

“By going to six storeys, we were able to free up the site, and provide the open space that the City of Fort St. John required, as well as provide soft green spaces for the residents of the buildings.

The courtyard we created is framed by the two L-shaped buildings and feels like a small park with ample seating, bermed lawns for recreation and relaxation, and various landscaped areas for creative play for children.”

Jordan Van Dyck – Associate, MGA | Michael Green Architecture

Whatever the construction method used, mid-rise buildings have several environmental benefits when compared to single-family dwellings. They have a smaller surface-to-volume ratio, which makes them more efficient in terms of energy use, and they create denser neighbourhoods that bring amenities and services closer to people’s homes, encouraging walking, cycling and transit use. These environmental benefits are further enhanced when mid-rise buildings are constructed in wood.

The sustainable attributes of wood are now well understood by most architects. They are founded on the premise that all wood used in construction

be harvested from third-party-certified, sustainably managed forests. Canada has the largest area of certified forests in the world (Figure 8.1).

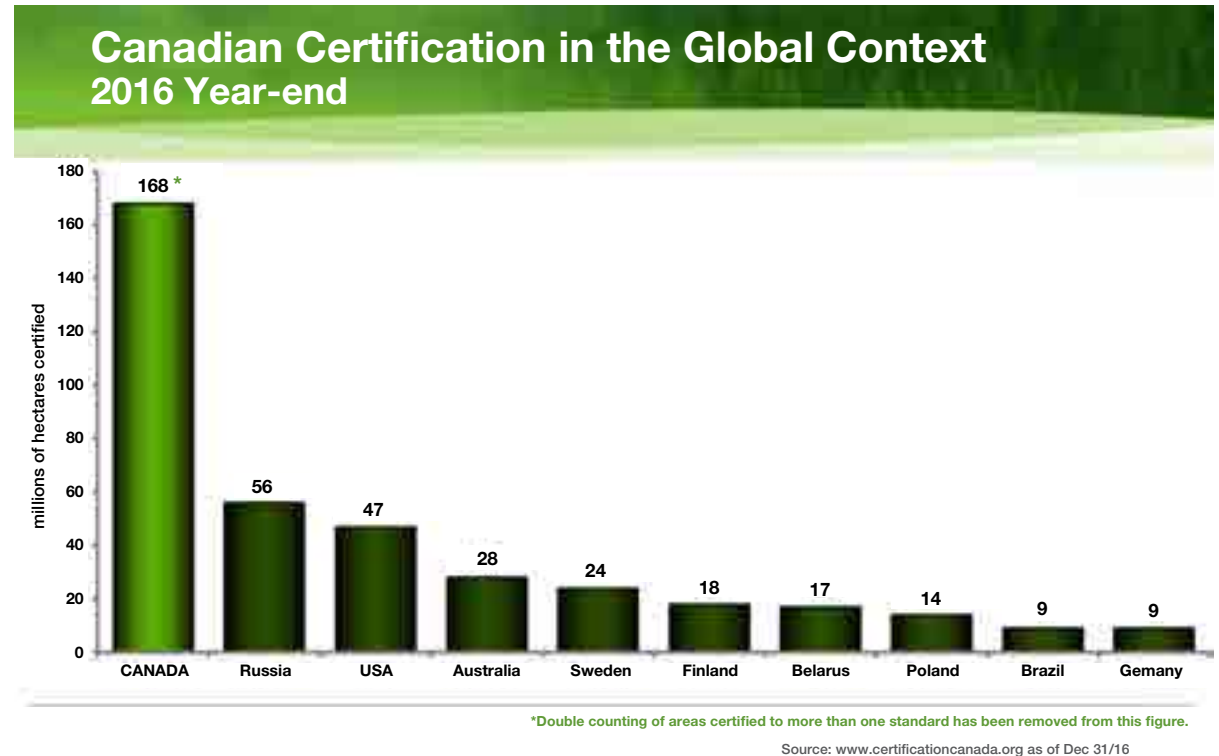

FIGURE 8.1 – AREA OF SUSTAINABLY MANAGED FORESTS IN CANADA AND INTERNATIONALLY

Whether administered by the Canadian Standards Association (CSA), the Sustainable Forestry Initiative (SFI) or the Forest Stewardship Council (FSC) (the three most common certification systems used in BC and Canada), sustainable forest management has several goals in common. These include: maintaining or increasing the volume of wood fibre contained in the forest; maintaining biodiversity and animal habitat; maintaining soil health and preventing erosion; and maintaining the natural mix of tree species. All such systems provide an assurance to design professionals and the public alike that building in wood does not compromise the ecological value of our forests.

Manufactured by the sun, wood is the only major construction material that is truly renewable. Furthermore, as trees use the sun's energy to create cellulose (the main component of wood fibre) they sequester carbon dioxide from the atmosphere. When trees are harvested to create buildings and other durable products, this carbon remains locked in the wood until it finally decays or is destroyed by fire (Figure 8.2).

Wood also requires minimal energy to be transformed into construction lumber, making it potentially a carbon negative product. In situations where wood products can be used in place of others with a greater carbon footprint (such as concrete and steel) the benefits can be multiplied by this substitution effect.

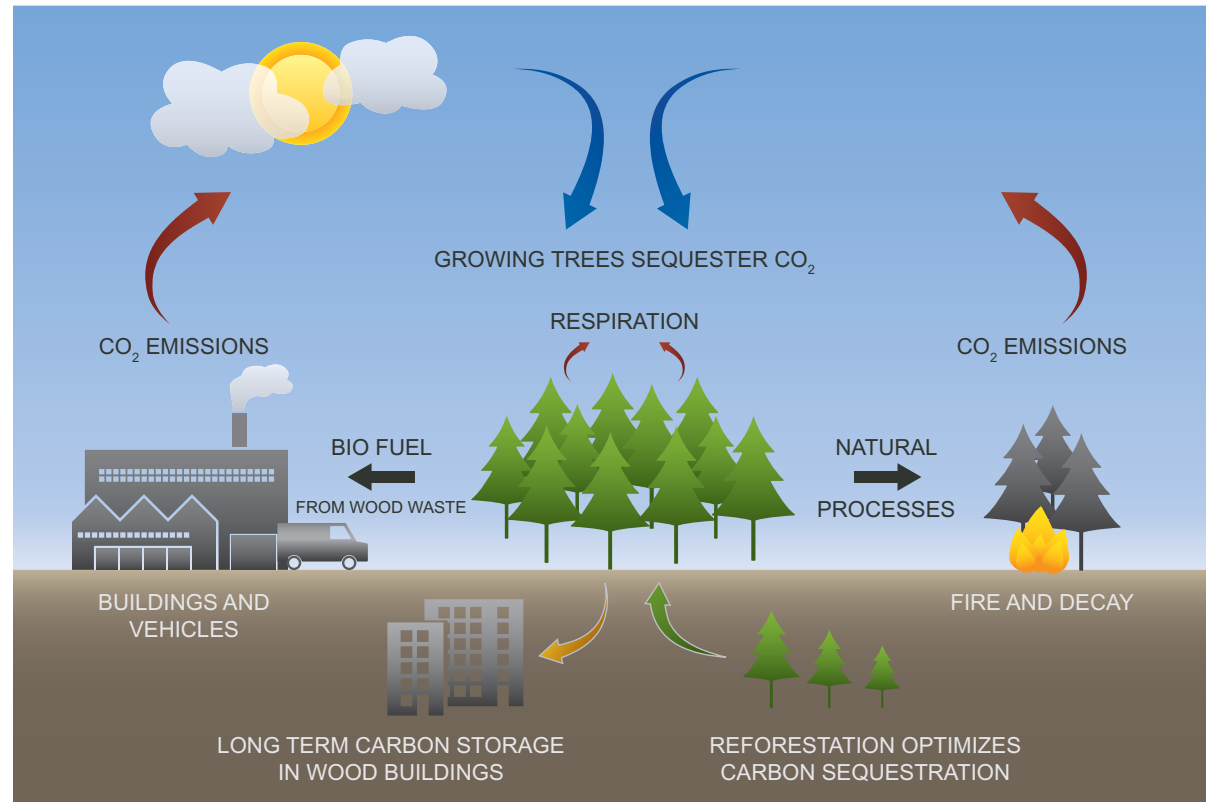

FIGURE 8.2 – THE CARBON CYCLE RELATING TO THE USE OF SUSTAINABLY MANAGED WOOD IN BUILDINGS

9. COST BENEFITS OF WOOD CONSTRUCTION

“The Ardea and Herons Landing are the first new rental buildings to be constructed in Saanich in 25 years. I don’t believe they would have been economically viable in anything other than wood-frame construction.”

Tony James – Principal, KPL James Architecture Inc.

In 2016, Atlantic **Wood WORKS!** published a research report entitled **Wood for Mid-rise Construction**. The report included analyses of the local practice environment, technical issues related to wood construction, and a Class C cost comparison between wood and other materials traditionally used in mid-rise buildings. The baseline for this cost comparison was a six-storey building in Kamloops, BC, for which comprehensive data was available.

The comparison was performed by QS Online Cost Consultants of Halifax, NS, who described the models as follows:

“All models are six-storey, and varying in typical composition from the base model which is comprised of one level of concrete construction and five levels of wood construction above, one model with all wood construction, one model with all concrete construction, and one model with all structural steel construction. All models are based on a 4’ foot deep frost foundation, without basement, slab-on-grade, and the ground floor is considered as vacant shell space for commercial tenants, while the upper five floors are for residential.”

Based solely on the initial capital costs, the consultants concluded that “**the cost analysis findings indicate that wood construction models are the least expensive to build.**”

In relation to the substitution of factory-produced elements for traditional site-built components, the consultants further stated:

“Although this report is not including impacts to soft costs or cash flow differentials, the result of extending any project’s duration, cascades into a direct impact to occupancy timing, construction financing costs, extended exposure to weather and seasons etc.”

“It would be reasonable to conclude that the return on investment for these manufactured products, is not in the hard or direct costs incurred during construction, but rather in the soft or indirect cost evaluations of the overall project achieved by shortening the overall duration of the project and gaining earlier occupancy.”

This suggests that the predictability of factory prefabrication, and its ability to compress construction times by overlapping different phases of work, can reduce the soft costs of a project and make wood construction an even more favourable option.

10. CONCLUSIONS

Over the past 20 years, sustainability has increased in importance as a driver of the design of cities and of the buildings that comprise them. Originally understood as simply an environmental issue, the definition of sustainability now embraces social and economic concerns.

As it has done for more than a century, wood-frame construction has evolved to reflect prevailing social values, and to embrace the potential of new materials and technologies. As shown by the projects featured in this best practice guide, wood-frame construction has

successfully scaled up in response to the need for denser, more compact communities, while still continuing to offer efficiency and economy of construction. Mid-rise buildings are being built by the same local labour, using locally sourced materials, and established construction techniques.

Even as performance expectations for mid-rise buildings increase, wood-frame construction will continue to adapt to the changing circumstances. It is expected that the provisions of the NBC (which already permit wood structures to be used for mercantile occupancies on the ground and first

floors of six-storey mixed-use buildings) will be adopted in BC and elsewhere, making the current concrete podium structures unnecessary. Other practices, such as prefabrication, will come into their own as their advantages are more widely recognized. Double stud exterior wall construction or full exterior insulation may emerge as the most effective way to accommodate the insulation levels required by tomorrow's energy codes.

In summary, we can continue to rely on wood-frame construction to deliver affordable and durable buildings, meeting the needs of communities for generations to come.



PROJECT CREDITS

SAIL

Owner/Developer: Adera Development Corporation
Architect: Rositch Hemphill Architects
Structural Engineer: Weiler Smith Bowers
General Contractor: Adera Development Corporation

HILLCREST VILLAGE

Owner/Developer: Cape Construction
Architect: MGA | Michael Green Architecture
Structural Engineer:
Read Jones Christoffersen Ltd. (Vancouver)
General Contractor: Cape Construction

THE ARDEA & HERONS LANDING

Owner/Developer: EY Properties Ltd.
Architect: KPL James Architecture Inc.
Structural Engineer:
Read Jones Christoffersen Ltd. (Victoria)
General Contractor: Farmer Construction Ltd.

THE SHORE

Owner/Developer: Adera Development Corporation
Architect: Integra Architecture
Structural Engineer: London Mah & Associates
General Contractor: Adera Development Corporation

SFU DOWNTOWN RESIDENCE

Owner/Developer: 308 Hastings Joint Venture
Architect: Raymond Letkeman Architects Inc.
Structural Engineer: Bogdanov Pao Structural Engineers
General Contractor: Vanmar Constructors Inc.



PUBLICATION FUNDING AND SUPPORT



NATIONAL FUNDER



Natural Resources
Canada

Ressources naturelles
Canada



Forestry Innovation
Investment

NATIONAL PARTNERS



StructureCraft



INDUSTRY FUNDERS



FOR MORE INFORMATION ON WOOD WORKS!, CONTACT: www.wood-works.ca • WOOD WORKS! HELP DESK: help@woodworks.org



Canadian
Wood
Council
Conseil
canadien
du bois

BC Program
1-877-929-9663

Alberta Program
1-780-392-1952

Ontario Program
1-866-886-3574

Québec Program
1-418-650-7193

Atlantic Program
1-902-667-3889

National Office
1-800-463-5091

US Program
1-858-243-1620