

Canadian
Wood
Council

Conseil
canadien
du bois



Request for Proposal

The Development of the CWC Wood Handbook for Builders

March 2020

Revised April 23, 2020

Due Dates	Activity
Monday, April 6 2020	Intention to Bid
Saturday, April 11 2020	Question period
Friday, April 17 2020	Answer Period (if applicable)
Friday, May 1 2020	Proposals Due
Friday, May 15 2020	Oral presentations – if requested
Monday, May 25 2020	Proponent selection announcement

TABLE OF CONTENTS

1	INTRODUCTION	3
1.1	Background	3
2	GENERAL CONDITIONS	4
2.1	Confidentiality/Non-Disclosure	4
2.2	Proponent's Proprietary Information	4
2.3	Conflict of Interest	4
2.4	Verification of Proponent's Proposal	4
2.5	Liability for Errors	4
2.6	Right of Rejection	5
2.7	Cost of Proposals	5
2.8	Proposal Validity Period	5
2.9	Right to Cancel	5
3	PROPOSAL INSTRUCTIONS AND TIME FRAMES	6
3.1	Intention to Bid	6
3.2	Proposal Delivery	6
3.3	RFP Questions	6
3.4	Schedule of Events	7
3.5	Evaluation of Proposals	7
3.6	Awarded Contract	8
4	PROPOSAL PREPARATION	9
4.1	General Preparation	9
4.2	RFP Response Format	9
4.3	Cost Proposal	11
4.4	Exceptions to the RFP	11
5	SCOPE OF SERVICES	12
5.1	Overview of Section	12
5.2	Project Background	12
5.3	Work Objectives	12
5.4	Scope, methodology, and detailed phases	13
5.5	Deliverables	14
	APPENDIX A	15
	APPENDIX B	86

1 INTRODUCTION

The Canadian Wood Council is seeking a vendor/service provider who will provide technical writing services for the notionally titled ‘Wood Handbook for Builders.’

The objective of this Request for Proposal (RFP) is to obtain proposals from vendors/service providers that may be used to establish a short list of potential vendors. Following oral presentations (if required) and reference checks, a preferred vendor will be selected and an agreement negotiated.

The vendor/service provider may submit proposals to write the entire CWC ‘Wood Handbook for Builders’ publication, or choose to write individual Chapters within the publication.

1.1 Background

The Canadian Wood Council (CWC) represents the Canadian wood products industry through a national federation of associations. The Mission of the Council is to expand market access and increase demand for Canadian wood products through excellence in codes, standards, regulations and education. The CWC’s vision is to be passionate, credible agents of change leading to an advanced and sustainable wood culture.

A role of the CWC is to act as the conduit for the transfer of technical knowledge for the people (builders, architects, engineers) who specify wood in construction. One way the CWC does this is by providing essential technical tools and field support needed to design and build with wood.

For a number of years, the Canadian Wood Council has developed publications for engineers, architects, building officials, builders, and developers such as the ‘Wood Design Manual’, the ‘Span Book’, the ‘Introduction to Wood Design’, as well as design tools such as WoodWorks® software and the ‘EffectiveR.ca’ wall thermal resistance calculator.

A new publication, notionally titled ‘Wood Handbook for Builders,’ will attempt to fill identified gaps for light wood frame and mass timber buildings. The Handbook will extend existing and available builder resources and focus on how buildings are constructed. It will document how construction practices are changes because of technology improvements and new wood products. The intended audience for this new publication is builders, technologists, and students.

The existing CWC publication ‘Introduction to Wood Building Technology,’ is an example of a publication that demonstrates the level of detail and length of content that is expected of this new publication.

2 GENERAL CONDITIONS

This RFP is not an offer to contract. CWC shall not be obligated in any manner to any Proponent until a written contract has been duly executed relating to an approved proposal. Neither the issuance of this RFP, nor the delivery of a proposal by a Proponent commits CWC to award a contract to any Proponent, even if all requirements stated in this RFP are met, nor limits CWC's right to negotiate in its best interest, nor to accept (nor to decline to accept) non-compliant proposals. CWC reserves the right to contract with a Proponent for reasons other than lowest price.

2.1 Confidentiality/Non-Disclosure

The information contained in this RFP (or accumulated through other written or verbal communication) is confidential and proprietary to CWC. It is for proposal purposes only and is not to be disclosed or used for any other purpose. It is solely for the Proponent organization's use and is not to be copied, scanned, or distributed to any other individual and/or company without prior written consent from CWC. All personnel should also be so advised of this clause.

2.2 Proponent's Proprietary Information

Proponents shall identify those specific portions of their proposals deemed to be proprietary, confidential, and legitimately under protection. CWC will neither accept nor honor requests to keep the entire proposal confidential.

CWC shall use only reasonable efforts to keep confidential those specific portions of the proposal identified as confidential by a Proponent. In the event of disclosure, however, CWC shall not be liable to the Proponent.

CWC undertakes to not share proprietary methodology with other Proponents.

2.3 Conflict of Interest

The Proponent shall disclose in its Proposal any potential conflict of interest between themselves (or their agents, principals, officers and employees) and CWC or its employees.

2.4 Verification of Proponent's Proposal

The Proponent shall authorize CWC to conduct such investigations as it may deem appropriate to verify the contents of the Proponent's proposal.

2.5 Liability for Errors

While CWC has used considerable efforts to ensure an accurate representation of information in this RFP, the information contained herein is supplied solely as a guideline for Proponents. The information is not guaranteed or warranted to be accurate by CWC, nor is it necessarily comprehensive or exhaustive. No information in this RFP is intended

to relieve Proponents from forming their own opinions and conclusions in respect to the matters addressed in this RFP.

2.6 Right of Rejection

CWC reserves the right to enter into discussions and/or negotiations with one or more qualified Proponents at the same time and to reject any or all responses to this RFP.

2.7 Cost of Proposals

Expenses incurred in the preparation of proposals in response to this RFP are the Proponent's sole responsibility.

2.8 Proposal Validity Period

Proposals are irrevocable and open for acceptance by CWC for a period of 90 days after the Submission Deadline.

2.9 Right to Cancel

CWC reserves the right to cancel this RFP process at any stage without liability to any Proponent.

3 PROPOSAL INSTRUCTIONS AND TIME FRAMES

This section contains instructions governing the proposal to be submitted.

3.1 Intention to Bid

Proponents must notify the CWC of their intention to bid by **4:00 PM (EST), Monday, April 6 2020**. Notification can be by email, or in writing. Please provide the name, address, telephone, and e-mail address for the Proponent contact who should receive answers to questions and RFP revisions and updates. Any Proponent who elects not to bid is requested to destroy this RFP.

Intentions to bid should be submitted in writing or by e-mail to the contact detailed in section 3.2 and 3.3 below.

3.2 Proposal Delivery

Deliver one (1) electronic copy of the proposal to the following address **not later than 4:00 PM (EST), Friday, May 1, 2020** (the 'Submission Deadline').

Reed Kelterborn
National Education Manager
Email: RKelterborn@cwc.ca

Note: CWC reserves the right not to consider proposals delivered after the Submission Deadline or sent by facsimile or e-mail, or delivered to any other location or contact person other than the above address and contact person.

3.3 RFP Questions

Proponents are requested to carefully review this RFP without delay for any ambiguity, conflict, discrepancy, omission, or other error.

Questions regarding this RFP are encouraged and should be submitted in writing or by e-mail to:

Reed Kelterborn
National Education Manager
CWC
400-99 Bank Street
Ottawa, ON K1P 6B9
Email: RKelterborn@cwc.ca

3.4 Schedule of Events

Due Dates	Activity
Monday, April 6 2020	Intention to Bid
Saturday, April 11 2020	Question period
Friday, April 17 2020	Answer Period (if applicable)
Friday, May 1 2020	Proposals Due
Friday, May 15 2020	Oral presentations – if requested
Monday, May 25 2020	Proponent selection announcement

3.5 Evaluation of Proposals

The CWC will conduct the evaluation of proposals in the following stages:

Stage I

Stage I will consist of a review to determine which proposals comply with all of the mandatory requirements (outlined in section 4). Proposals, which do not comply with all of the mandatory requirements, may be disqualified and not evaluated further.

Stage II

Stage II will consist of a scoring by the CWC of each qualified proposal on the basis of the rated criteria, shown below:

Criteria Category	Points
Response to Statement of Work (Proposed Workplan)	30
Proponent's Qualifications and Writing Sample	50
Project management plan	20
Total	100

Stage III

Stage III will consist of the evaluation of price/cost. Each Proponent will receive a percentage of the total possible points allocated to price for the particular chapter it has bid on. Pricing will be scored based on a relative pricing formula described below:

Points for rate = 50
 Points for price = 50
 Total available points = 100

$$(lowest\ rate\ or\ price / Proponent\ rate\ or\ price) \times total\ points = Proponent\ points$$

For example, if the lowest bid rate for a particular chapter is \$120/hr, that Proponent will receive 100% of the 50 possible points for bid rate. If the next Proponent has a bid rate for the same chapter at \$150/hr, that Proponent will receive 40 points because $((120/150) \times 50) = 40$.

Similarly, if the lowest bid price for a chapter is \$10,000, that Proponent will receive 100% of the 50 possible points for bid price. If the next Proponent has a bid rate for the same chapter at \$15,000, that Proponent will receive 33 points $((10,000/15,000) \times 50) = 33$.

The lowest Proponent will thus receive the full 100 points (50 + 50) while the next Proponent will receive 73 points (40 + 33) out of a possible 100 points.

Cumulative Score

All scores from Stage II and Stage III will be added and, subject to satisfactory reference checks, the highest scoring Proponent will be selected to enter into a formal contract with the CWC, described in section 3.6. The maximum cumulative score is 200 points.

3.6 Awarded Contract

The selected Proponent will be required to enter into a formal Contract with CWC and the award of the Contract is conditional upon the parties agreeing upon the terms and conditions of the final Contract.

The CWC reserves the right to award the Contract to 1) a single proponent to develop the entire 'Wood Handbook for Builders' publication or, 2) multiple Proponents to develop individual Chapter(s) in the 'Wood Handbook for Builders' publication. Separate contracts will be awarded to each Proponent.

4 PROPOSAL PREPARATION

All submitted proposals must adhere to the specifications contained herein. Proponents are not restricted from providing additional details if they feel they would meet or exceed CWC's objectives.

The proposal to should be clear, complete, and concise.

4.1 General Preparation

- Number pages consecutively within a section using section and page numbering (e.g. page 3-30).
- Follow the proposal outline in Section 4.2. For each response, identify the RFP item to which the proposal is responding to.

4.2 RFP Response Format

The Proponent should provide their RFP response in the following format:

Letter of Transmittal

The letter of transmittal should be no longer than two (2) pages and should include the following:

- a) A brief statement of the Proponent's understanding of CWC's business and the project requirements.
- b) A brief statement of services and products to be provided.
- c) Contact information (name, address, e-mail, phone numbers and role in the company) for the principal individuals to be contacted regarding the information in the RFP.

Table of Contents

The table of contents should include clear and complete identification of the materials submitted by section and page number.

Project Human Resources

The proposal should include information about the qualifications of the firm, and all individuals who will work on the project. The Proponent must submit the qualifications for each individual author. In addition, the qualifications of any support personnel who will be participating in the development of the publication content must also be included in the Proposal.

Proponent qualifications include, but are not limited to:

- (a) A description of the Proponent, the organization, number of full-time employees, its experience and expertise.
- (b) A summary of qualifications for all individuals who will work on the project including:

- a. Education, including completed degrees, diplomas, and certificates
 - b. Expertise (e.g. building science, low-rise building envelopes etc.)
 - c. Specific project experience
 - i. Ensure that the experience is specific to the Chapter(s) that are being bid on. If the Proponent is bidding on multiple Chapters, the Proponent must organize the qualifications in such a way that specifically addresses the content of that Chapter.
 - d. Experience in publication development
- (c) A sample of writing done by the Proponent, representative of the quality of writing to be provided to CWC in all draft and final material to be submitted.
- (d) Provide a minimum of three (3) client references.
- a. For each reference please provide: an overview of the work the Proponent has completed including size of the project and timeframe, the company name, contact person's name, phone number and e-mail address.

Project Management Plan

The proposal should address and describe the project management plan, including:

- (a) The project management approach and the organizational structure, including reporting levels and lines of authority.
- (b) The approach to quality control including details of the methods used in ensuring quality of the work, and response mechanisms in the case of errors, omissions, delays, etc.
- (c) The approach to ensure compliance to the work schedule and regular status reporting to CWC.

Response to Statement of Work (Proposed Workplan)

The body of the proposal should address the scope of services in Section 5.4. It should be structured in a fashion that is easy for the evaluation panel, established by CWC, to follow and to evaluate. The proposal should also identify any issues and challenges associated with meeting the objectives of this project as described in Section 5, and it should outline how the Proponent plans to address these issues and challenges if awarded the contract.

The Proponent must indicate which Chapter(s) in the 'Wood Handbook for Builders' they wish to develop. If the Proponent intends to write the entire publication, then that must be indicated this in the proposal. The Proponent should provide an estimate of the length of each Chapter (word count).

If submitting a proposal with multiple authors, then the Proponent must include information which lists each Chapter and its intended author.

Budget

Please see section 4.3

4.3 Cost Proposal

In order for proper comparison to other proposals, please standardize costing for any consultation on a 'per hour' basis. Please list provincial tax or Goods and Services tax separately from the project estimate.

Please break down costs on a Chapter by Chapter basis. For example, if bidding on Chapter 1 and 3, the Proponent's budget should be as follows:

- the estimated number of hours for Chapter 1 development x hourly rate, and
- the estimated number of hours for Chapter 3 development x hourly rate

If the proposal has multiple authors, please break down costs on a Chapter by Chapter basis, in addition to an average rate. For example, if Author A and Author B intend to write Chapter 1 and 3 together, the budget should be as follows:

- Chapter 1 costs:
 - Author A work hours x Author A hourly rate = amount A
 - Author B work hours x Author B hourly rate = amount B
 - **Chapter 1 average rate** = (amount A + amount B) / (Author A work hours + Author B work hours)

- Chapter 3 costs:
 - Author A work hours x Author A hourly rate = amount A
 - Author B work hours x Author B hourly rate = amount B
 - **Chapter 2 average rate** = (amount A + amount B) / (Author A work hours + Author B work hours)

See section 3.6 awarding contract details.

4.4 Exceptions to the RFP

There may be instances where the Proponent's services are not offered in a manner consistent with the specification in this RFP. In such cases, it is permissible to take exception to portions of the RFP. The exceptions should be clearly identified. If necessary, attach an additional page describing the scope of the exceptions and a summary of any advantages these exceptions represent to CWC.

5 SCOPE OF SERVICES

5.1 Overview of Section

This section of the RFP is intended to provide the prospective Proponent with the information necessary to develop a competitive proposal. The Statement of Work is a complete description of the tasks to be completed, results to be achieved, and/or the goods to be supplied.

5.2 Project Background

The new CWC publication, temporarily titled ‘Wood Handbook for Builders,’ will help to address the transition from commonly-understood low-rise to emerging mid-rise buildings, and tall wood building typologies. The Handbook will be relevant to college construction technology programs, in a similar way that the ‘Introduction to Wood Design’ is relevant to an undergraduate university wood engineering courses, and currently used by numerous post-secondary educators across Canada.

The CWC has developed an outline for the ‘Wood Handbook for Builders’, which is intended to guide the development of this publication. The outline describes the organization of the publication. The outline also describes each chapter’s contents, including suggested topics and narratives, sources of information, and suggested illustrations. Proponents are encouraged to review the outline and propose improvements.

The outline is provided in Appendix A of this Request for Proposal.

The CWC has also established a Steering Committee of industry experts to provide feedback and guidance on the development of the publication. The Steering Committee has also been involved in the development of the ‘Wood Handbook for Builders’ outline. The Proponent will be expected to continue to seek feedback from the Steering Committee for this project.

The list of Steering Committee members is provided in Appendix B of this Request for Proposal.

5.3 Work Objectives

The successful Proponent will be expected to:

1. Review the ‘Wood Handbook for Builders’ Outline for currency and completeness.
2. Identify proposed changes to the Outline and update the Outline as necessary.
3. Review Outline as necessary
4. Engage the existing steering committee to review project materials, to ensure the final publication meets the needs of the intended audience.
5. Create content for chapters in the Handbook, including identifying illustrations (figures, diagrams, photographs).

The Successful Proponent is not responsible for the production of the final publication layout. A separate contractor will be retained by the CWC to fulfill the responsibilities of a publication editor. The editor will be responsible for the final publication layout and preparation of print-ready files.

Similarly, the Successful Proponent is not responsible for the production of the final publication illustrations. A separate contractor will be retained by the CWC to fulfill the responsibilities of a publication illustrator.

5.4 Scope, methodology, and detailed phases

a) Review and update of the outline for the Wood Handbook for Builders

Proponents are encouraged to review the outline and propose improvements. The successful Proponent will ensure the content suggested by the outline is current and complete. If necessary, the successful Proponent will undertake the research required to update the Outline, reference list, and suggested illustrations list.

The successful Proponent will provide the draft and final outlines and reference lists to the CWC for review and comment.

b) Engage with the existing project Steering Committee

To help ensure the final publication will meet the needs of the intended audience, the successful Proponent is required to have the project material reviewed by the project Steering Committee. Please see Appendix B for a list of Steering Committee members. The CWC will provide the contact details for each Steering Committee member to the Successful Proponent.

The successful Proponent shall meet with the Steering Committee at several milestones as outlined in the Proponent's Workplan. The Steering Committee will advise the successful Proponent and the CWC throughout the development of the publication, and identify any revisions that must be made to the publication. The CWC will review the Steering Committee's recommendations and direct the Successful Proponent of any alterations to the content that must be made.

The successful Proponent will have in place, the required resources to host and facilitate the Steering Committee conference calls and/or meetings. The Successful Proponent is also expected to undertake secretariat duties for the Steering Committee.

c) Coordination with other authors

Where multiple proponents have been awarded contracts, the Successful Proponents should consider the effort required to coordinate with other chapter authors to ensure consistency of the Handbook content.

d) Create draft content for each Chapter(s) of the Handbook

The successful Proponent will research, draft, and develop each chapter(s) of the Publication. This work should draw on the references identified in the updated Outline.

e) Identify illustrations and supplementary content

The Successful Proponent will identify and describe the necessary illustrations (figures, diagrams, photographs etc.) that accompany their writing. The Successful Proponent will indicate the location of the illustrations in their Chapter, and describe what the illustration will look like. New illustrations should be submitted by the Successful Proponent in the form of hand sketches, facsimile, photocopy or examples. The Successful Proponent is not responsible for the production of the final publication illustrations. A separate contractor will be retained by the CWC to fulfill the responsibilities of a publication illustrator.

f) Reviews and revisions

The successful Proponent will develop each chapter of the Publication separately, and submit each chapter to CWC for review and comment. The draft of each chapter will be revised to reflect the comments received. The frequency of draft content reviews should be clear in the Proponent's Workplan (see section 4.2).

The successful Proponent should also accommodate for at least two (2) Steering Committee review cycles (draft content review and final draft review), to be determined by the Proponent's Workplan (see section 4.2).

g) Prepare final documents

The Successful Proponent will prepare the final documents, to be submitted to the CWC and/or publication editor for print production.

5.5 Deliverables

Final deliverables will be determined by the Proponent's Workplan and response to the statement of work. See section 4.2 for more details.

APPENDIX A – OUTLINE FOR CWC WOOD HANDBOOK FOR BUILDERS

Proposed Topics for “Wood Technology Handbook for Builders” textbook

By: buildABILITY Corporation

Introduction

For a number of years, the Canadian Wood Council has developed publications for engineers, architects, building officials, builders, and developers such as the “Wood Design Manual”, the “Span Book”, the “Introduction to Wood Design”, as well as design tools such as WoodWorks® software and the “EffectiveR.ca” wall thermal resistance calculator.

This new publication, titled “Wood Technology Handbook for Builders,” will attempt to fill an identified technical publication and resource gap for light wood frame and mass timber buildings. The Handbook will extend existing and available builder resources and focus on how buildings are constructed, why engineers and architects specify certain details, and how construction practices are changing because of technology improvements and new wood products. The Handbook will help to address the transition from commonly-understood low-rise to emerging mid-rise buildings as well as from other materials traditionally used in larger buildings to new mass timber buildings, including similarity and differences in design details and construction.

The Handbook will also be relevant to college construction technology programs, in a similar way that the Introduction to Wood Design is relevant to an undergraduate university wood engineering courses, and currently used by numerous post-secondary educators across Canada.

How to read this outline/document

The proposed topics for the “Wood Technology Handbook for Builders,” are organized into six chapters and a Teacher’s compendium. This outline will describe each chapter’s contents using four parts (A, B, C and D).

Part A contains a complexity, benefit, cost and time analysis.

Part B contains the proposed outline for the chapter and will describe the chapter’s different sections, sources of information that the sections reference (see section below on references) and any recommendations from the Wood Technology Handbook Steering Committee.

Part C is an expanded description of the chapter contents. This part will describe the intended narrative and content of the chapter sections.

Part D includes pictorial examples of the section contents, from existing references and sources of information. These are meant to be representative only, and may be outdated.

References

As part of the initial gap analysis and literature review, 52 references were reviewed. The references that were reviewed are listed below. If a reference is directly cited for a part or section, that reference will be listed under the 'reference materials' heading in its corresponding part or section.

	Title	Publisher	Year
1	Wood-Frame House Construction	U.S. Department of Agriculture	1975
2	Fundamentals of Carpentry: Practical Construction	American Technical Society	1977
3	Limit States of Design of Wood Structures	Morrison Hershfield Ltd	1986
4	Fire Safety Design in Wood Buildings	Canadian Wood Council	1996
5	Introduction to Wood Building Technology	Canadian Wood Council	1997
6	Wood-Frame Envelopes Best Practice Guide Building Technology	CMHC	1999
7	Wood-Frame Envelopes in the Coastal Climate of British Columbia	CMHC	1999
8	Wood Reference Handbook	Canadian Wood Council	2000
9	Details for Conventional Wood Frame Construction	American Wood Council	2001
10	Graphic Guide to Frame Construction	Taunton Press	2002
11	Plank and Beam Framing for Residential Buildings	American Wood Council	2003
12	Engineering Guide for Wood Frame Construction	Canadian Wood Council	2004
13	Tongue and Groove Roof Decking	American Wood Council	2004
14	Heavy Timber Construction	American Wood Council	2004
17	Introduction to Wood Design	Canadian Wood Council	2005
18	Wood Design Manual	Canadian Wood Council	2005
19	Fire and Sound Control in Wood-Frame Multi-Family Buildings	CMHC	2006
20	Design of Wood Frame Structures for Permanence	American Wood Council	2006
21	Building Enclosure Design Guide - Wood-Frame Multi-Unit Residential Buildings	BC Housing	2011
22	Meeting Residential Energy Requirements with Wood-Frame Construction	American Wood Council	2012
23	Canadian Wood-frame House Construction	CMHC	2013
24	CHBA Builders' Manual	Canadian Home Builders' Association	2013
25	Guide for Designing Energy-Efficient Building Enclosures for Wood-Frame Multi-Unit Residential Buildings in Marine to Cold Climate Zones in North America	Homeowner Protection Office, Canadian Wood Council	2013
26	Post-Frame Buildings	American Wood Council	2013
27	Code and Construction Guide for Housing	Ministry of Municipal Affairs and Housing (Ontario)	2014
28	Design of Fire-Resistive Exposed Wood Members	American Wood Council	2014
29	Tall Wood buildings in Canada - A Technical Guide for Design and Construction	FPIInnovations	2014
30	Illustrated User's Guide - NBC 2015: Part 9 of Division B	National Research Council Canada	2015
31	Mid-Rise Wood Frame Construction Handbook	FPIInnovations	2015

32	Reference Guide: Mid-rise Wood Construction in the Ontario Building Code	Morrison Hershfield	2015
33	Prescriptive Residential Wood Deck Construction Guide	American Wood Council	2015
34	Illustrated Guide: Building Safe and Durable Wood Decks and Balconies	BC Housing	2016
35	Mid-Rise Wood Construction: A Cost-Effective and Sustainable Choice For Achieving High-Performance Goals	Think Wood	2016
36	APA Engineered Wood Construction Guide	APA	2016
37	APA Advanced Framing Construction Guide	APA	2016
38	Guide technique sur la conception de bâtiments de 5 ou 6 étages à ossature légère en bois	Cecobois	2016
39	Acoustic Testing of CLT and Glulam Floor Assemblies	National Research Council Canada	2016
40	CLT Handbook	FPIInnovations	2016
41	Illustrated Guide: R22+ Effective Walls in Wood-Frame Construction in British Columbia	BC Housing	2017
42	Ontario's Tall Wood Building Reference	Ministry of Natural Resources and Forestry, Ministry of Municipal Affairs	2017
43	Residential Structural Design Guide	U.S. Department of Housing and Urban Development Office of Policy Development and Research	2017
44	Flame Spread Performance of Wood Products Used for Interior Finish	American Wood Council	2017
45	Costing comparison of 6 storey structure: wood, concrete, steel	WoodWORKS Atlantic	2017
46	Mid-Rise 2.0 Innovative Approaches to Mid-Rise Wood Frame Construction	WoodWORKS, CWC	2017
47	Mid-Rise Best Practice Guide: Proven Construction Techniques for five- and six-storey wood-frame builders	BC Housing	2018
48	Wood Frame Construction Manual for One-and Two-Family Dwellings	American Wood Council	2018
49	Fire-Resistance-Rated Wood Floor and Wall Assemblies	American Wood Council	2018
50	Wood Construction Systems (woodsolutions.com.au)	Forest and Wood Products Australia	2018
51	Acoustics and Mass Timber: Room-to-Room Noise Control	WoodWORKS	2018
52	Rethinking Timber Buildings	ARUP	2019
53	Fundamentals of Building Construction: Materials and Methods	John Wiley and Sons	2004
54	Accommodating Shrinkage in Multi-Story Wood-Frame Structures	WoodWORKS	2019

Outline Part 1: Introduction

1-A Complexity, benefit, cost and time analysis

Complexity	Low	Information is readily available
Benefit	High	Case studies will provide good references.
Cost	Low	Information is readily available for the majority of topics. Further research may be required to provide a complete overview of the economic benefits of wood construction, especially with regards to mid-rise and high-rise buildings. Information is also readily available for case studies. The majority of work for the case studies would be in organization and layout.
Time required		

1-B Proposed Outline

	Content – Part 1 Introduction	References	SC recommended
1.1	General information		
1.2	Historical use of wood in buildings	5, 6	
1.3	Contemporary Wood Buildings	6, 42	Yes
	1.3.1 Single Family Residential 1.3.2 Multi-unit Residential 1.3.3 Medical 1.3.4 Mercantile 1.3.5 Offices 1.3.6 Schools 1.3.7 Religious 1.3.8 Industrial 1.3.9 Recreational		
1.4	Wood as a resource – introduction to the forestry industry	8	
1.5	Why wood? Benefits of Building with wood	1, 5, 24, 25,	Yes
	1.5.1 Economic benefits, and affordable housing	45, 50, 52	
1.6	Sustainable and net zero buildings 4.8.1 Energy performance 4.8.1.1 Canadian Building Codes and Energy Codes 4.8.1.2 ASHRAE Standard 90.1 4.8.1.3 Voluntary energy performance standards 4.8.2 Carbon emissions 4.8.3 Construction waste	24, 25	
1.7	Case Studies 1.7.1 Brock Commons, Vancouver, British Columbia, Canada 1.7.2 Wood Innovation and Design Centre, Prince George, British Columbia (BC), Canada 1.7.3 British Columbia (BC), Canada 1.7.4 Sail, Vancouver, BC, Canada 1.7.5 Herons Landing & The Ardea, Saanich, BC, Canada 1.7.6 Hillcrest Village, Fort St. John, BC, Canada 1.7.7 The Shore, North Vancouver, BC, Canada	46, 47, 52	Yes

	1.7.8 SFU Downtown Residence, Vancouver, BC, Canada 1.7.9 King Edward Villa, Vancouver, BC, Canada 1.7.10 Virtuoso, Vancouver, BC, Canada		
--	---	--	--

1-C Content

1.1 General Information

This first introductory part draws primarily from CWC’s Introduction to Wood Building Technology publication. Other publications may also be referenced. The introduction section will include a high-level overview of the Wood Handbook’s content, intended audience and applicable uses.

1.2 Historical use of wood in buildings

This section will provide an overview of the use of wood as a building material in Canada. Several references can be used for this section, including the Canada Mortgage and Housing Corporation’s (CMHC) publication, “Wood frame envelopes: Best Practice Guide Building Technology.” It will also tie into a new CWC Architectural book (scheduled for 2021), referring the reader to a similar section within the architect book.

The section will describe heavy timber frames to balloon framing in the mid-1800s, practices in the 1900s, and to contemporary energy efficient construction and standards.

1.3 Contemporary wood buildings

This section will include photographic examples of contemporary wood buildings. This section will also describe the current scenario of wood frame building in Canada, including applicable building code changes and technologies. Examples of contemporary buildings can be sourced from existing references (See Section 1-B), with some sample pages given below in Section 1-D. The handbook will include a complete list of building occupancy types that can be constructed in Canada with wood as the main structural element:

- 1.3.1 Single Family Residential
- 1.3.2 Multi-unit Residential
- 1.3.3 Medical
- 1.3.4 Mercantile
- 1.3.5 Offices
- 1.3.6 Schools
- 1.3.7 Religious
- 1.3.8 Industrial
- 1.3.9 Recreational

1.4 Wood as a resource – introduction to the forestry industry

This section will introduce wood as a natural resource. This section will provide an updated overview of Canada’s forests, similar to the summary provided in the Canadian Wood Council’s “Wood Reference Handbook.” This section will lead directly into the following sections on the benefits of wood construction.

1.5 Why wood?

This section will introduce the benefits of wood as the main construction material, and will include sub-sections that describe the environmental and economic benefits of wood.

Sub-sections will address the issue of housing affordability in Canada, and to a lesser extent, around the world. It will provide a brief narrative on the role that wood and timber buildings can play in improving housing affordability. The economic benefits of wood construction, especially with regards to mid-rise and high-rise buildings, may require additional research.

The last sub-section will describe how timber and wood products are diverse, and can provide the basis for light, versatile and creative design solutions. This section will follow the Dan Tingley's, "Wood Construction Systems," issued by Forest and Wood Products Australia.

- 1.5.1. Economic benefits, affordable housing, and value engineering

1.6 Sustainable and net zero buildings

This section will present sustainability considerations when designing wood buildings. The considerations will be grouped into three general categories: energy performance, carbon emissions, and construction waste. This section will also highlight the important role that timber buildings can play in reducing the construction industry's carbon emissions, explain how timber's material properties reduce a building's carbon footprint, and describe wood's role in what is now described as a "circular economy"

Section 1.6.2 will provide an overview of the role that wood buildings play in reducing Canada's carbon emissions. It will briefly introduce the broader policy framework that specifies Canada's goals of reducing its carbon emissions. This section will also introduce various voluntary standards that specify carbon reduction requirements for buildings, such as the LEED standard.

- 1.6.1 Energy performance
 - 1.6.1.1 Canadian Building Codes and Energy Codes
 - National Building Code of Canada
 - National Energy Code for Buildings
 - 1.6.1.2 ASHRAE Standard 90.1
 - 1.6.1.3 Voluntary energy performance standards
- 1.6.2 Carbon emissions and the circular economy
- 1.6.3 Construction waste
- 1.6.4 Carbon calculations

1.7 Case studies

This section will present several case studies of completed wood buildings across Canada. This section could also include exceptional buildings around the world. The suggested case studies in this section is based on existing building case studies that have been published (see references in table above). This list will be expanded as necessary, based on CWC case studies as they are published. Other case studies that will be included are a church project, a school, and a gymnasium.

- Brock Commons, Vancouver, British Columbia, Canada
- Wood Innovation and Design Centre, Prince George, British Columbia (BC), Canada
- Sail, Vancouver, BC, Canada
- Herons Landing & The Ardea, Saanich, BC, Canada
- Hillcrest Village, Fort St. John, BC, Canada
- The Shore, North Vancouver, BC, Canada
- SFU Downtown Residence, Vancouver, BC, Canada
- King Edward Villa, Vancouver, BC, Canada
- Virtuoso, Vancouver, BC, Canada
- Fast and Epp new office, Vancouver, BC, Canada
- 2102 Keith Avenue, Vancouver, BC, Canada

The structure of the content for each case study is based on the 'Mid-Rise Best Practice Guide' published by Wood Works and the Canadian Wood Council. Each case study will present their strategies for achieving each of the following:

- Featured projects
- Designing for increased loads
- Controlling shrinkage and differential movement
- Fire safety and noise control
- Building envelope considerations
- Construction practices
- Cost benefits

1-D Examples of Content

Wood Building Technology 5

1.2 Contemporary Wood Buildings





Because wood is strong, economical, available, and easy to work, it is the structural material of choice for residential construction in North America. Many countries are reviewing and adapting North American residential construction methods to meet local housing needs.

But the suitability of wood as a structural building material does not end with residential construction. Wood is also being used successfully for larger commercial buildings.

The photograph above shows a stunning example of wood used as both a structural and finishing element in a residential building. The following pages include photographs depicting a range of budgets and building types, both residential and commercial.

Introduction 6

Single-Family Residential







Builders' Guide Steering Committee - Do not duplicate or distribute

Wood Building Technology 7



Introduction 8

Multi-unit Residential



Builders' Guide Steering Committee - Do not duplicate or distribute

2. FEATURED PROJECTS

Sail, Vancouver, BC

Completion: 2014

Sail is a two-phase market condominium project in the Wesbrook Place neighbourhood, a 95-acre "urban village" under development on the Point Grey campus of the University of British Columbia. The Phase 1 and 2 buildings include a total of 170 apartment units (Figure 2.1).

The buildings are six storeys in height, constructed using traditional light wood framing for walls, engineered wood joists for floors, and occasional engineered wood posts, beams, headers, and lintels where load requirements dictate. The wood-frame structure is built on top of a two-storey underground parking garage of reinforced concrete construction (Figures 2.2 and 2.3).

In this much coveted location, the apartments at Sail include high-end finishes and fixtures, large balconies, in-floor radiant heating, and nine-foot ceilings.



FIGURE 2.1 – SAIL IS A TWO-PHASE MARKET CONDOMINIUM PROJECT LOCATED IN THE WESBROOK PLACE NEIGHBOURHOOD OF THE UNIVERSITY OF BRITISH COLUMBIA CAMPUS IN VANCOUVER

The Shore, North Vancouver, BC

Completion: 2017

This four-phase market condominium project is located close to the centre of North Vancouver (Figure 2.10). The site borders Mosquito Creek, with its hiking trails and nature walks, and many apartments have balconies or roof decks with views of either the North Shore mountains or Burrard Inlet. The buildings are five and six-storey wood-frame constructed on grade, or on top of a basement parking garage of concrete construction (Figures 2.11 and 2.12).

The complex is arranged around a central courtyard featuring multiple art installations, and has a total of 359 apartment units. Ranging in size from 480 sq. ft. to 1090 sq. ft., the apartments feature high-end finishes and fixtures, floor-to-ceiling windows, and in-floor radiant heating.

As a way to compare the impact of different approaches to construction on economy, efficiency, and performance, the Adera Development Corporation — which was both the developer and construction manager — used traditional site-construction methods and factory prefabrication on different phases of the project. Adera also explored different approaches to noise control and acquired first-hand knowledge of this aspect of building performance, for which little independent testing has been done to date.

All phases of The Shore are constructed using light wood-frame walls, engineered wood I-joist floors, and nail-laminated timber (NLT) elevator shafts, with engineered wood posts, beams, and headers where loading requirements dictate. The close proximity of the buildings led to the installation of dry sprinkler lines on the eaves of each completed phase to protect them from damage should a fire break out while the next phase was under construction.



FIGURE 2.10 – THE SHORE IS A FOUR-PHASE MARKET CONDOMINIUM PROJECT LOCATED ADJACENT TO MOSQUITO CREEK IN NORTH VANCOUVER

KING EDWARD VILLA



12 Credit: Jim Toppert



3.1: King Edward Villa NE-SW cross section

Completed in the spring of 2017, King Edward Villa is a six-storey mixed-use building located on the corner of East King Edward and Kingsway Avenues on Vancouver's east side. The ground level commercial space and the single level of underground parking are constructed in concrete, with 77 apartments, ranging in size from 420-square-foot studios to 700-square-foot two-bedroom units, occupying the five storeys of wood frame construction above (Fig. 3.1).

On behalf of the family who had owned the previously C-2 (four-storey commercial) zoned lot for many years, the design team led by GBL Architects approached the City of Vancouver to rezone the property and construct a rental apartment building under the Rental 100 program. Permission was granted for a six-storey building with an overall floor area determined by the application of the pre-existing setback requirements to the new structure (Fig. 3.2).



Fig. 3.2: Aerial photo showing urban context



Fig. 3.3: Restricted site access at rear of property

With a four-foot setback from the sidewalk, the plan of the building follows the property line, making an oblique angle where the two streets meet. The ends of the building abut the property line at either side of the site, giving the long front and rear elevations a north-northeast and south-southwest orientation, respectively. The rear yard is narrow, with an opening width of only 40 feet between the building footprint and a large tree (Fig. 3.3). Leading south to the adjacent lane, this was the only vehicular access to the site.

A Low Energy Solution

Once a development permit had been received and building permit drawings were in process, the project was let as a construction management contract. Up to this point, it was assumed that the building would be constructed using conventional nominal 2x6 wood framed exterior walls to meet the energy requirements of ASHRAE 90.1 and achieve a LEED Gold certification as mandated by the City of Vancouver.

The contract was awarded to Performance Construction, who persuaded the developer to consider a low energy option based on Passive design principles, using a similar business case to that described previously for The Heights.

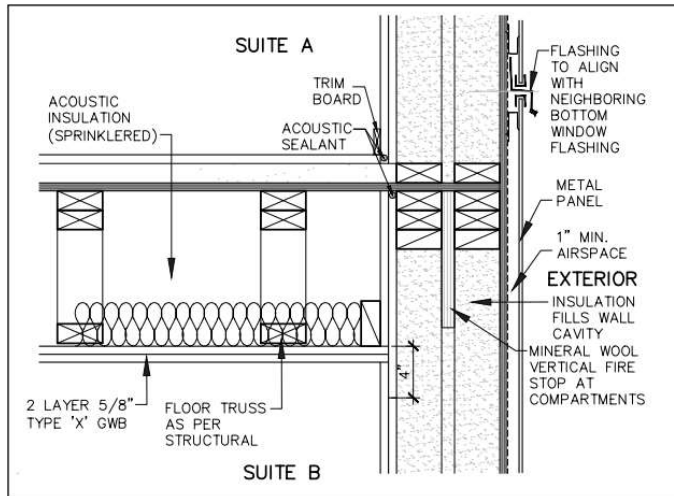

Fig. 3.4: Panel exterior wall at wood floor

The energy conservation strategies are the same in this project as in 388 Skeena, but the implementation differs in detail from the strict requirements of Passive House.

The super-insulated envelope was achieved by using two nominal 2x4 wood stud walls with a one-inch space between them. The exterior sheathing is plywood with a vapour permeable (breathable) peel-and-stick membrane, that also acts as an air barrier. The entire wall depth is filled with two layers of spray-applied cellulose insulation that achieves an R-value of 28. The cellulose eliminates heat transfer by convection and, because it is hygroscopic (able to absorb and release moisture), it provides added insurance against interstitial condensation (Fig. 3.4).

The inside of the wall is lined with airtight drywall with a vapour barrier paint on the interior face. Two layers of 5/8-inch fire-rated drywall were required to achieve the one-hour fire resistance rating mandated by code, and these were installed with gaskets around power receptacles and other openings, and the edges were sealed with fire-resistant caulking (Fig. 3.5).



Fig. 3.5: The edges of the drywall were caulked to meet fire and acoustic requirements

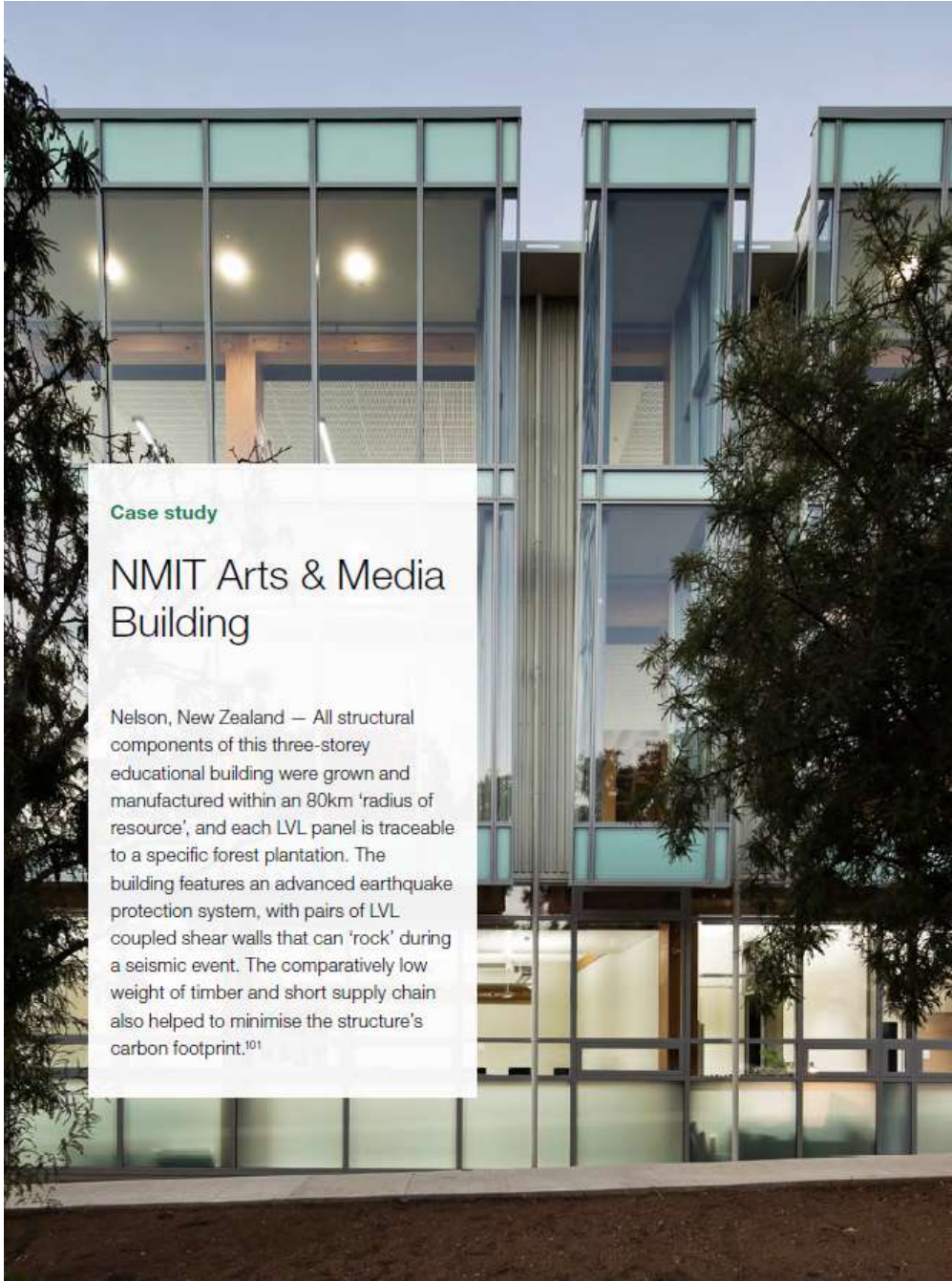

Case study

NMIT Arts & Media Building

Nelson, New Zealand — All structural components of this three-storey educational building were grown and manufactured within an 80km 'radius of resource', and each LVL panel is traceable to a specific forest plantation. The building features an advanced earthquake protection system, with pairs of LVL coupled shear walls that can 'rock' during a seismic event. The comparatively low weight of timber and short supply chain also helped to minimise the structure's carbon footprint.¹⁰¹



Reference material

Anderson, L.O. *Wood-Frame House Construction*. U.S Department of Agriculture: Washington, 1975

ARUP. *Rethinking Timber Buildings*. ARUP: London, 2019

Canada Mortgage and Housing Corporation. *Wood-Frame Envelopes: Best Practice Guide Building Technology*. Canada Mortgage and Housing Corporation, 2004

Canadian Home Builders' Association. *CHBA Builders' Manual*. Canadian Home Builders' Association: Ottawa, 2013

Canadian Wood Council. *Wood Reference Handbook*. Canadian Wood Council: Ottawa, 2000

Homeowner Protection Centre and Canadian Wood Council. *Guide for Designing Energy-Efficient Building Enclosures for Wood-Frame Multi-Unit Residential Buildings in Marine to Cold Climate Zones in North America*. Canadian Wood Council: Ottawa, 2013

Mid-Rise 2.0 Innovative Approaches to Mid-Rise Wood Frame Construction. Wood-WORKS BC, Canadian Wood Council: 2017

Mid-Rise Best Practice Guide: Proven Construction Techniques for five- and six-storey wood-frame builders. Wood-WORKS BC, Canadian Wood Council: 2018

Ministry of Natural Resources and Forestry, and Ministry of Municipal Affairs. *Ontario's Tall Wood Building Reference*. Ministry of Natural Resources and Forestry, and Ministry of Municipal Affairs: 2017.

QS Online Cost Consultants. *Six Storey Model Comparison*. Atlantic Woodworks: Amherst, 2017

Tingley, Dan. *Wood Construction Systems*. Forest and Wood Products Australia, 2018

Outline Part 2: Wood Building Products

2-A Complexity, benefit, cost and time analysis

Complexity	Moderate	Information is readily available, needs curating
Benefit	Moderate	
Cost	Moderate	High volume of information exists, with some exceptions (hybrid buildings), needs curating
Time required		Some further research required for mid-rise and high rise detail drawings

2-B Proposed Outline

	Content – Part 2 Wood Building Products	References	SC recommended
2.1	Introduction		
2.2	Basic Properties of Wood Building Products		
	2.2.1 Dimensional change 2.2.2 Mold and decay 2.2.3 Preservative treatments	5, 6, 18, 23, 29, 50	Yes
2.3	Wood structural members and components		
	2.3.1 Sawn lumber 2.3.2 Sawn timber	5, 50	
2.4	Engineered wood products		
	2.4.1 Glulam 2.4.2 SCL 2.4.2.1. LVL 2.4.2.2. LSL 2.4.2.3. PSL 2.4.3 NLT 2.4.4 CLT 2.4.5 I-joists 2.4.6 Trusses	5, 36	
2.5	Panel Products – sheathing and decking	5	

2-C Content

2.1 Introduction

This section will provide a builder-oriented summary of the CWC Introduction to Wood Design chapter on material properties, with an emphasis on how these material properties were considered by the engineer and architect when determining detailing, and how they vary among the vast array of wood products available.

It will be demonstrated that decisions on material handling and storage methods should consider the basic material properties of wood, and that some products are more susceptible to

damage than others. It will also describe how understanding wood properties is key to successfully integrating wood with other structural materials.

This introduction will point to detailed examples in other sections related to moisture and movement: such as brick veneer over wood structure, steel column balconies attached to wood studs, accommodating differential movement in concrete elevator shafts within midrise buildings.

This introduction will also point to structural examples related to wood properties, such as weak perpendicular-to-grain resistance and how certain connections facilitate splitting due to this weakness. Specific examples include: hanging heavy equipment through a hole drilled into a wood beam near the bottom of the beam; if notching and drilling holes is required, why an engineer should be consulted, and enlightening to the best locations in structural members to drill or notch (i.e. low stress areas); how bolt placement is key to mitigating splitting of wood etc.

2.2 Basic Properties of Wood Building Products

Introductory text about timber and wood products, including the natural variability in wood fibre properties, such as the variability between structural species used in Canada, and the variability across the log itself, will set the basis.

In addition, the anisotropic properties of wood and how it relates to the strength and stiffness of timber will be described. Similarly, how wood density can be used as an indicator for other key timber properties such as strength and stiffness, fire resistance and ease of machining.

2.2.1. Dimensional change

This section describes how the change in moisture content of wood products causes shrinkage (when it dries) and swelling (when it becomes wet). The fibre saturation level will be described, and how wood below this level shrinks and expands will be detailed. Specifically, how shrinkage or expansion occurs at different rates in the three principle grain directions: radially – across the growth rings, tangentially – around the growth rings, and longitudinally – along the grain, and at different rates for each species.

The difference between tangential and radial shrinkage rates and how it can result in the distortion in a board's cross-section as the timber dries will be depicted (see sample figure below).

Figure 2.2
Shrinkage
effects

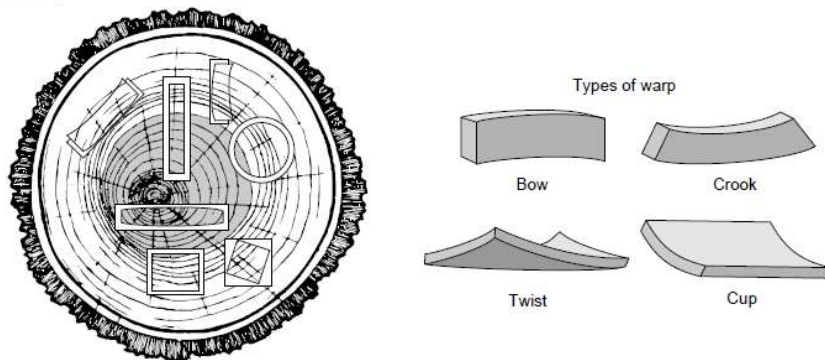

This section will describe how dimensional change is addressed during the production of lumber products to avoid warping, splitting and checking. It will list the actions required to minimize the possibility of dimension change and deterioration.

It will then expand on these basic principles to explain how dimensional change must be understood in order to properly detail the building.

2.2.2 Mold and Decay

This section will describe how wood deteriorates by decay. It will include the definition of decay as the softening, weakening or total decomposition of wood by fungi: microorganisms that eat organic material. The four conditions that must be met for wood-eating fungi to survive (and decay to occur) will be described. Most importantly, this intro will point to other sections that describe how to test for and recognize decayed wood, and how to prevent it in the first place (storage and handling, and detailing). This section will describe the growing interest of constructing more durable buildings, and how wood, properly detailed, is a very durable material that can last centuries.

It will then point to a chapter that provides illustrated examples of good detailing vs bad detailing, Examples: vapour retarders, rain screens, exterior details that hold water vs drain away water. (Reference durability section of cwc.ca (durable-wood.com)).

2.2.3 Preservative treatments

This section will provide an overview of the preservative treatments used for wood products. This section will present the types of preservatives commonly used for treating wood products, and their applicable standards. It will also describe the Use Classes of products in CSA O80 and as referenced in the NBC.

2.3 Wood Structural members and components

This section will provide information on the different types of wood building products available, that are commonly used for main structural members.

2.3.1 Sawn Lumber species and grades

This section will explain the process of *grading*, and how lumber grades are established in accordance with the National Lumber Grades Authority. The section will include an overview of how lumber is visually assessed. This section will also present commercial species of combinations of lumber, typical structural lumber sizes, grades, moisture content, and dimension lumber sizes. The figures from the CWC's Introduction to Wood Building Technology are shown below.

Table 2.1
Commercial
species combi-
nations of
lumber

Species combination	Abbreviation	Species included in combination
Douglas Fir-Larch	D.Fir-L	Douglas fir Western larch
Hem-Fir	Hem-Fir	Pacific coast hemlock Amabilis fir
Spruce-Pine-Fir	S-P-F	Spruce (all species except coast sitka spruce) Jack pine Lodgepole pine Balsam fir Alpine fir
Northern Species	Northern	Western red cedar Red pine Ponderosa pine Western white pine Eastern white pine Trembling aspen Largetooth aspen Balsam poplar Any other Canadian species graded in accordance with the NLGA rules

Table 2.2
Typical struc-
tural lumber
sizes, grades,
and moisture
content

Use	Common sizes		Visual grades	Moisture content
	mm	in. (nom.)		
Wall studs	38 x 89 38 x 140 38 x 184	2 x 4 2 x 6 2 x 8	Stud	S-Dry or S-Grn
Joists, rafters, and built-up beams	38 x 184 to 38 x 286	2 x 8 to 2 x 12	Select Structural No.1 No.2 No.3	S-Dry or S-Grn
Purlins	64 x 184 to 89 x 286	3 x 8 to 4 x 12	Select Structural No.1 No.2 No.3	S-Grn only

Table 2.3
Dimension
lumber sizes

Nominal size in.	Surfaced green (S-Grn) size in.	Surfaced dry (S-Dry) size in.	Metric size mm
2 x 2	1-9/16 x 1-9/16	1-1/2 x 1-1/2	38 x 38
3	2-9/16	2-1/2	64
4	3-9/16	3-1/2	89
6	5-5/8	5-1/2	140
8	7-1/2	7-1/4	184
10	9-1/2	9-1/4	235
12	11-1/2	11-1/4	286
3 x 3	2-9/16 x 2-9/16	2-1/2 x 2-1/2	64 x 64
4	3-9/16	3-1/2	89
6	5-5/8	5-1/2	140
8	7-1/2	7-1/4	184
10	9-1/2	9-1/4	235
12	11-1/2	11-1/4	286
4 x 4	3-9/16 x 3-9/16	3-1/2 x 3-1/2	89 x 89
6	5-5/8	5-1/2	140
8	7-1/2	7-1/4	184
10	9-1/2	9-1/4	235
12	11-1/2	11-1/4	286

Notes:

- 38mm (2") lumber is readily available as S-Dry.
- S-Dry lumber is surfaced at a moisture content of 19% or less.
- After drying, S-Grn lumber sizes will be approximately the same as S-Dry lumber.
- Tabulated metric sizes are equivalent to imperial S-Dry sizes, rounded to the nearest millimetre.

Other specific wood building product definitions and grades will also be introduced in this section. These include:

- Machine Stress Rated Lumber
- Fingerjoined lumber

2.3.2 Sawn Timber species and grades

This sub-section will follow the same format as the above section, but will deal specifically with larger sized Sawn Timber. This section will follow the CWC's "Introduction to Wood Building Technology," sections on sawn timber. Sample figures are shown below.

Table 2.4
Typical sizes and grades of sawn timber for structural applications

Use	Common sizes		Visual grade
	mm	in. nom.	
Posts (square sections)	140 x 140	6 x 6	Select Structural No.1 No.2
	to 394 x 394	to 16 x 16	
Beams (rectangular sections)	140 x 241	6 x 10	Select Structural No.1 No.2
	to 292 x 394	to 12 x 16	

Notes:

1. Availability of large sizes should be checked with suppliers.
2. S-P-F and Northern species groups may not be available in sizes larger than 241 x 241mm (10" x 10" nom.).
3. All material is available as S-Grn only.

Table 2.5
Typical sizes and grades of sawn timber

Nominal size in.	Surfaced green (S-Grn) size in.	Metric size mm
6 x 6	5-1/2 x 5-1/2	140 x 140
8	7-1/2	191
10	9-1/2	241
12	11-1/2	292
14	13-1/2	343
16	15-1/2	394
8 x 8	7-1/2 x 7-1/2	191 x 191
10	9-1/2	241
12	11-1/2	292
14	13-1/2	343
16	15-1/2	394
10 x 10	9-1/2 x 9-1/2	241 x 241
12	11-1/2	292
14	13-1/2	343
16	15-1/2	394
12 x 12	11-1/2 x 11-1/2	292 x 292
14	13-1/2	343
16	15-1/2	394

Notes:

1. Timbers are always surfaced green.
2. Tabulated metric sizes are equivalent to imperial dimensions.

2.4 Engineered wood and mass timber components and systems

This section will provide information on the different types of engineered wood building products that are commonly used for main structural members, including the following sub-sections:

- 2.4.1 Glulam
- 2.4.2 SCL
 - 2.4.2.1. LVL
 - 2.4.2.2. LSL
 - 2.4.2.3. PSL
- 2.4.3 NLT
- 2.4.4 CLT
- 2.4.5 I-joists
- 2.4.6 Trusses

This section will compare structural properties of wood products, including the bending resistance, tension resistance, and compression resistance used for strength as well as stiffness values, to give an idea of possible substitutions that could be feasible, with the approval of an engineer. Comparisons of fire properties, preservative treatments (and relative treatability), durability and durability treatments, will also be included. Typical specifications that should be expected on drawings from the engineer for various products will also be described. This section will also provide a table from the Introduction to Wood Design regarding span length ranges, in order to get an idea of the strength and stiffness of members without necessarily getting into structural numbers. In addition, production processes will also be described within each sub-section.

2.5 Panel products & Sheathing

This section will describe sheathing with panel products and decking, that are used as structural elements. This section will follow the same format as the CWC's Introduction to Wood Building Technology. In addition, it will explain the roles of panel products, and references the APA Building for High Wind Resistance, Raised Heel trusses, and Nail-based sheathing for siding and trim attachment.

The section will include information on available grades, typical sizes, and CSA standards (sample figures below). The section will be organized to include the following sub-sections:

- 2.5.1 Sheathing
 - Plywood
 - Oriented strand board
- 2.5.2 Plank Decking

Table 2.14
CSA O437
sizes for
OSB and
waferboard

Imperial thickness (in.)	Metric thicknesses for the following grades (mm)		
	O-2	O-1	R-1
1/4	6.00	6.35	6.35
5/16	7.50	7.90	7.90
3/8	9.50	9.50	9.50
7/16	11.0	11.1	11.1
15/32	12.0		
1/2	12.5	12.7	12.7
19/32	15.0		
5/8	15.5	15.9	15.9
23/32	18.0		
3/4	18.5	19.0	19.0
7/8	22.5		
1-1/8	28.5		

Note:

Panel sizes are 4' × 8' (1220 × 2440 mm) or cut to size.

Larger sizes up to 8' × 24' (2440 × 7320 mm) are available on special order.

The preservative treatments used for panel products and sheathing will be introduced. Applicable standards, and classes of products in CSA O80 will be described.

2-D Examples of Content

Specific examples of content have been provided in their respective sub-sections above.

Reference material

APA – The Engineered Wood Association. *Engineered Wood Construction Guide*. APA – The Engineered Wood Association, 2016

Burrows, John. *Canadian Wood-frame House Construction*. Canada Mortgage and Housing Corporation: Canada, 2013

Canada Mortgage and Housing Corporation. *Wood-Frame Envelopes: Best Practice Guide Building Technology*. Canada Mortgage and Housing Corporation, 2004

Canadian Standards Association. *General requirements for wood preservation CAN/CSA-O80*. Canadian Standards Association, 2015

Canadian Wood Council. *Introduction to Wood Building Technology*. Canadian Wood Council: Ottawa, 1997

Canadian Wood Council. *Wood Design Manual*. Canadian Wood Council: Ottawa, 2005

Karacabeyli, Erol, and Lum, Conroy. *Technical Guide for the Design and Construction of Tall Wood buildings in Canada*. FP Innovations, 2014

Tingley, Dan. *Wood Construction Systems*. Forest and Wood Products Australia, 2018

Outline Part 3: Structural Systems

3-A Complexity, benefit, cost and time analysis

Complexity	Moderate	Information is readily available
Benefit	Moderate	
Cost	Moderate	Information is readily available
Time required		This part is extensive and content heavy.

3-B Proposed Outline

	Content – Part 3 Structural Systems	References	SC recommended
3.1.	Loads and Limit states design		
	3.1.2 Design Criteria 3.1.2.1 Vertical/gravity loads 3.1.2.2 Horizontal/lateral loads 3.1.2.3 Other	3, 5, 18	
3.2	Gravity Systems and vertical load paths		
	3.2.1. Beams 3.2.2. Columns 3.2.3. Joists 3.2.4. Plates 3.2.5. Trusses 3.2.6. Panels (mass timber)	3, 43	
3.3	Lateral load resisting systems		
	3.3.1 Shearwalls 3.3.2 Diaphragms	43	
3.4	Light wood framing		
	3.4.1. Features of light framing 3.4.2. Types of framing 3.4.3. Building Code requirements 3.4.4. Floor design 3.4.5. Wall design 3.4.6. Roof design 3.4.7. General guidelines 3.4.8. Differences between three storeys and four to six storey	5, 8	
3.5	Heavy Timber		
	3.5.1. Description of Post and Beam Construction 3.5.2. Heavy Timber Construction 3.5.3. Erection	1, 5	
3.6	Mass Timber		
	3.6.1. Conventional framing versus mass timber 3.6.2. Concrete and steel construction versus mass timber 3.6.3. Opportunities and challenges of mass timber 3.6.4. Hybrid buildings 3.6.4.1 Mass timber and mass concrete	5, 29, 42	

	<ul style="list-style-type: none"> 3.6.4.2 Mass timber and steel 3.6.4.3 Connections and details 3.6.5. Mass timber examples 		
3.7	Connections		
	<ul style="list-style-type: none"> 3.7.1. Light connections <ul style="list-style-type: none"> 3.7.1.1. Nails 3.7.1.2. Screws 3.7.1.3 Proprietary screws 3.7.1.4. Framing connectors 3.7.2. Heavy connections <ul style="list-style-type: none"> 3.7.2.1. Bolts 3.7.2.2. Lag Screws 3.7.2.3. Timber Rivets 3.7.2.4. Examples of Mass timber connections 3.7.3. Timber joinery 3.7.4. Adhesives 3.7.5. Connection details <ul style="list-style-type: none"> 3.7.5.1. Wood to wood 3.7.5.2. Wood to masonry/concrete 3.7.5.3. Wood to steel 3.7.6. Opportunities for CNC milling 3.7.7. Applicable standards 		
3.8	Shrinkage in wood frame buildings		
	<ul style="list-style-type: none"> 3.8.1. Non-uniform shrinkage 3.8.2. Metal connections with solid sawn timber or glue-laminated timber 3.8.3. Shrinkage and finish material 3.8.4. Shrinkage and plumbing, electrical and mechanical systems 3.8.5. Elevator shaft to wood frame 3.8.6. Steel post balconies connecting to wood frame 		
3.9	Integrating Mechanicals		
	<ul style="list-style-type: none"> 3.9.1. Integrating heating systems 3.9.2. Integrating ventilating 3.9.3. Integrating plumbing 3.9.4. Integrating rooftop renewables 		
3.10	Typical framing details		
	<ul style="list-style-type: none"> 3.10.1. Light wood framing details <ul style="list-style-type: none"> 3.10.1.1. Floor framing 3.10.1.2. Columns 3.10.1.3. Beams 3.10.1.4. Wood joists 3.10.1.5. Wall framing 3.10.1.6. Roof framing 3.10.1.7. Shearwall and Diaphragms 3.10.2. Heavy timber, and Post and Beam details <ul style="list-style-type: none"> 3.10.2.1. Detailing for dimensional change 3.10.3. Mass timber details 3.10.4. Examples for controlling shrinkage and differential movement 		

3-C Content

3.1 Making sense of loads

This section will introduce the typical loads that must be resisted by the building's structural system. It will differentiate between dead loads and movable loads (live loads). It will identify the range of live loads that push and pull on the building including (snow, wind, people, furniture). This section will attempt to make the way we measure loads real for the builder. It will differentiate between loads on residential buildings and loads on commercial buildings. It will also present the various ways loads resolve themselves within the supported element as shear bending moment, deflection, and vibration. It will discuss how structural members fail, and how failure is assessed. It will review deflection limits for floors, and other building systems. At some point, it will compare load measurements in imperial units and metric.

This section will provide a builder narrative to understanding the loads that could affect a building. Examples of these would be why a narrow roof has high snow loads, and other practical, as well as on-site applications. It will also relate building code load requirements to easy to understood phenomenon for e.g. snow loading on narrow roofs, or loads on guards.

The gravity load path will be the most familiar to builders. Diagrams will demonstrate the relative ease of determining breaks in the load path, such as cutting out or severely weakening a joist. Builders are generally less familiar with lateral load paths, and therefore this section will also include case studies and examples of these loads on buildings. Other loads that are often misunderstood by builders, such as the uplift load path, and resisting wind uplift loads, will also be described, with case studies and examples. Each load and their explanations will be separated into their own sub-sections.

These sub-sections will also introduce concerns as they relate to resisting high wind forces, and address the pros and cons of using less wood sheathing, often seen in new wood buildings. This section will also reference subsequent Parts on Building Information Modelling (BIM), and how BIM software could help reduce on-site corrections.

The section will address and provide definitions for the following specified loads:

- 3.1.2 Design Criteria
 - 3.1.2.1 Vertical/gravity loads
 - D – Dead loads
 - E – Earthquake/seismic loads
 - L – Live loads
 - S – Snow and rain loads
 - W – Wind loads
 - 3.1.2.2 Horizontal/lateral loads
 - H – Lateral loads due to earth pressure
 - E – Earthquake/seismic loads
 - W – Wind loads
 - 3.1.2.3 Other
 - P – Permanent effects caused by prestress
 - T – Loads due to temperature, shrinkage and settlement effects

3.2 Gravity load resisting systems and vertical load paths

This section refers back to the discussion in 3.1 for gravity loads and uplift load paths. This section will also illustrate the uplift wind load path. Specifically, how the roof is connected to the foundation, through all the walls. Better practise options will be included as discussion. The goal of this section will be to help builders understand how the performance of buildings is affected by the detailing and sizing of its structural members. This section will reference the APA's "Building for High Wind Resistance in Light-Frame Wood Construction," and the Institute for Catastrophic Loss Reduction's (ICLR), "Increasing High Wind Safety for Canadian Homes: A Foundational Document for Low-Rise Residential and Small Buildings," publication.

The key message in this section will be how each member resists the specific loads it is designed to resist, and how altering these members on site has consequences. For example, notching and drilling holes, different placement of members that may cause eccentric loads or cross-grain bending; changing bracing that is designed to resist lateral torsional buckling, cutting truss members, all have consequences that will need to be addressed (or the change should be avoided).

The importance of the location of the gravity and uplift system members, and of adequate connections to complete the load path will be emphasized. For example, hurricane straps placed on the gypsum side instead of the wood sheathing side is ineffective, and using them without wood sheathing is significantly less effective than using them with wood sheathing.

Brief sub-sections which contain specific information for each main structural component such as:

- 3.2.1. Beams
- 3.2.2. Columns
- 3.2.3. Joists
- 3.2.4. Plates
- 3.2.5. Trusses
- 3.2.6 Panels

Sample figures illustrating vertical load paths are provided below.

FIGURE 2.1 Vertical Load Path for Gravity Loads

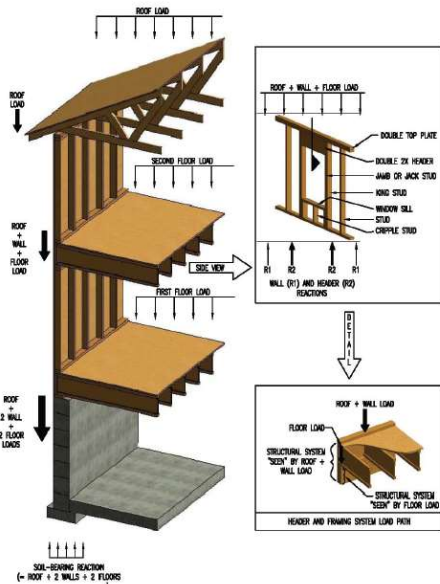
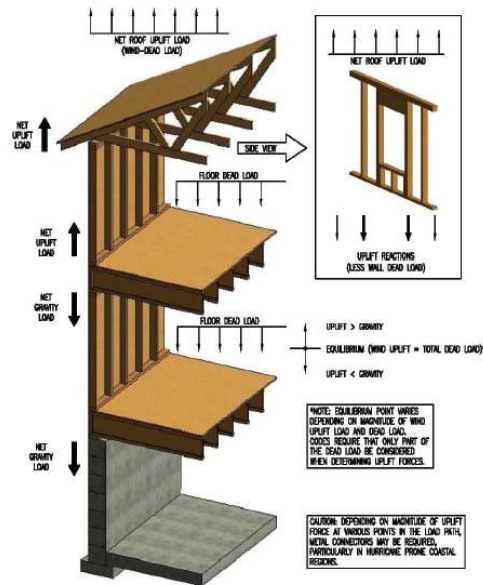

FIGURE 2.2 Vertical Load Path for Wind Uplift



3.3 Lateral Systems and lateral load paths

This section will include the definition of lateral load paths, followed by brief sub-sections which contain specific information for each structural component.

This first sub-section (3.3.1) will address braced walls, as defined by article 9.23.13 in the NBC. This section will show the history of prescriptive lateral load resisting systems. This sub-section will also include a description of NBC 9.23.13, particularly the conditions where no wind design or seismic design is required, and the potential implications of these requirements. The complete load path from roof sheathing to the foundation will be illustrated. Braced walls (i.e. conventionally framed walls) will be compared to fully engineered shearwalls, with a discussion of redundancies in light frame buildings that provide for extra strength in low-rise buildings. This sub-section will also include recommendations for better building, referencing ICLR's "Increasing High Wind Safety for Canadian Homes: A Foundational Document for Low-Rise Residential and Small Buildings," publication. Additional references to Thor Matteson's "Wood-framed Shear wall Construction," APA's "A guide to the 2018 IRC Wood Wall Bracing Provisions," BCHousing's "Illustrated Guide to seismic design," and NBC 9.23.13 -2020 will be made.

Repercussion of changes to designs, not following shearwalls schedules, incorrectly sized nails (especially short nails, even with the correct penetration length, and slightly different diameter nails) and over-driven nails will be discussed. Why screws are ok for gypsum, and for wood sheathing resisting wind, are ok, but not for seismic design. Why gluing wall sheathing in seismic areas is not appropriate. Illustrating strength differences between different nailing spacing and sheathing thicknesses will also be done.

Sub-section 3.3.2 may also include a section on mass timber shearwalls, including the types of fasteners expected on site, and why a simple substitution may not be feasible. The major differences in design

concept will be the main discussion. This will require additional expertise, and will reference the new Advanced Engineering book, as well as AWC's SDPWS -2021, if complete. This material will be included only if time permits.

The lateral systems section will include the following sub-sections:

- 3.3.1. Braced walls (i.e. 9.23.13 of NBC)
- 3.3.2 Shearwalls
- 3.3.3. Diaphragms
 - floor and roof assemblies clad with structural sheathing panels
 - hold downs
 - drag struts

Sample figures for the lateral systems and load paths are provided below.

FIGURE 2.3 Lateral Load Path

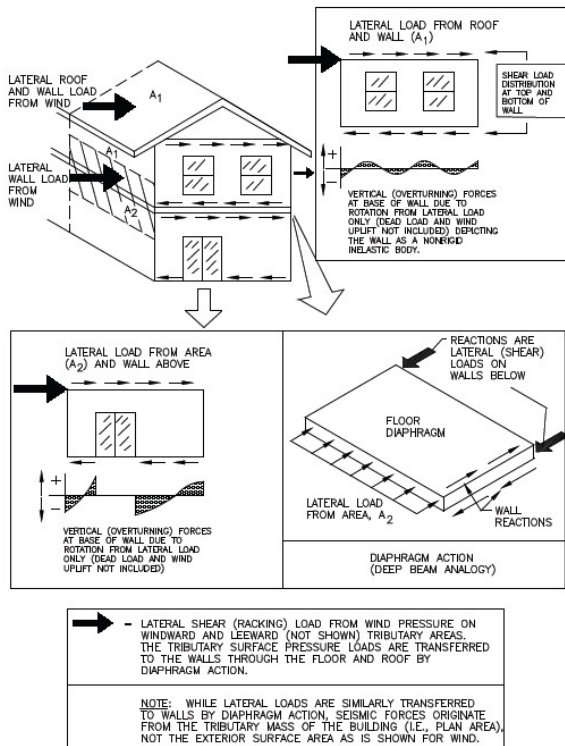
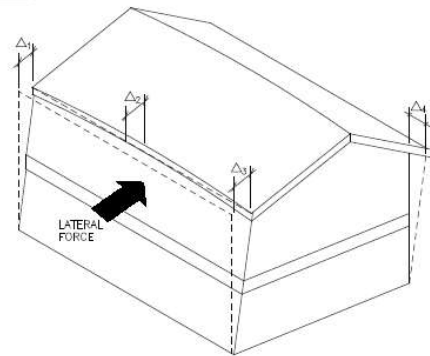

FIGURE 2.4 Building Deformation Under Lateral Load



NOTE: IF STIFFNESS OR LOAD IS NONSYMMETRICAL BUILDING ROTATION OCCURS ($\Delta_1 \neq \Delta_3$) AND LOADS ARE DISTRIBUTED BY TORSION ($\Delta_2 \neq 0$) AS WELL AS BY DIRECT SHEAR IN THE DIRECTION OF THE LATERAL FORCE. THIS CONDITION VARIES BUT IS A REALITY FOR MOST DESIGNS. Δ_2 IS THE BENDING DEFORMATION OF THE HORIZONTAL DIAPHRAGM (I.E., ROOF).

3.4 Light Wood framing

This section will introduce the two most common methods used to construct light wood-frame buildings (balloon and platform framing). This section will also outline the requirements for wood-frame construction under Part 9 and Part 4 of the National Building Code of Canada. This section will largely reference the content in the Canadian Wood Council's 'Introduction to Wood Building Technology', and 'Wood Reference Handbook'.

This section will also include commentary that highlights the differences in wood framing techniques for three storeys and four to six storey construction.

The section will include the following sub-sections:

- 3.4.1. Features of light framing
- 3.4.2. Types of framing
- 3.4.3. Building Code requirements
- 3.4.4. Floor design
- 3.4.5. Wall design
- 3.4.6. Roof design
- 3.4.7. General guidelines
- 3.4.8. Differences between three storeys and four to six storey

Sample figures from 'Introduction to Wood Building Technology,' are provided below.

Figure 3.1
Platform frame
construction

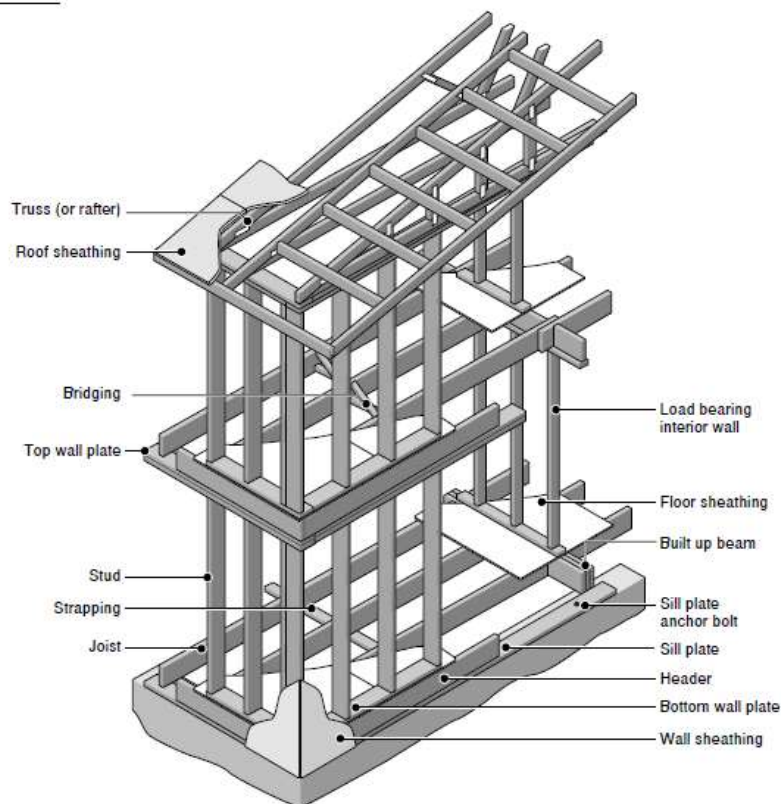

3.5 Heavy Timber – Post and Beam construction

This section will use the same content layout as the Canadian Wood Council’s ‘Introduction to Wood Building Technology,’ chapter titled, ‘post and beam construction.’ The section will describe the characteristics of post and beam construction. References to heavy timber construction will be also be made where applicable. A reference to the CWC’s “Introduction to Wood Design for Architects,” textbook (currently under production) will also be made. The section will include the following sub-sections:

- 3.5.1. Description of Post and Beam Construction
- 3.5.2. Heavy Timber Construction
- 3.5.3. Erection

3.6 Mass timber – low rise commercial, mid-rise and tall wood buildings

This section provides information mass timber structural systems for low rise commercial, mid-rise and tall wood buildings. The characteristics of mass timber systems will be described. Mass timber systems will be compared with conventional light wood framing, and concrete and steel construction. The opportunities and challenges to mass timber will be presented in separate sections. The best span for CLT and NLT floor systems will be discussed.

A section will be dedicated to hybrid buildings. This section will contain specific considerations when constructing hybrid buildings, and the interaction of mass timber and non-combustible materials. It will highlight previously mentioned material differences, and how the detailing is very important to follow. This section will require new research.

Finally, sub-section 3.6.5. will provide examples of mass timber, tall wood buildings. This section will use the case studies that have been constructed, or currently in construction, from FP Innovations’ Technical Guide for the Design and Construction of Tall Wood Buildings, and the Ontario Ministry of Municipal Affairs’ Tall Wood Building Reference



- 3.6.1. Conventional framing versus mass timber
- 3.6.2. Concrete and steel construction versus mass timber
- 3.6.3. Opportunities and challenges of mass timber
- 3.6.4. Hybrid buildings
 - 3.6.4.1 Mass timber and mass concrete
 - 3.6.4.2 Mass timber and steel
 - 3.6.4.3 Connections and details
- 3.6.5. Mass timber examples
 - Case studies: Origine (Quebec), Brock Commons (BC), Fast + Epp office 9BC), and possibly 2102 Keith Avenue (BC)

3.7 Connections

This section will focus on the connectors and fasteners used to join elements together in wood structures. This section will describe how shrinkage should be taken in consideration where wood framing is combined with materials not subject to dimensional change. For example, masonry block elevator shafts in a wood frame building.

Other topics to be included in this section include: detailing metal connections to prevent distress due to wood shrinkage, differential movement problems for connections, plumbing stacks, elevator shafts, and other services. This section is able to draw material from a large variety of sources.

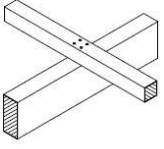
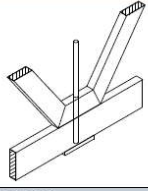
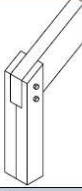
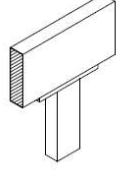
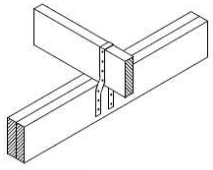
The section will begin by describing the connection approaches and types. Definitions for connection types will be given, and explained through diagrams and illustrations (examples below).

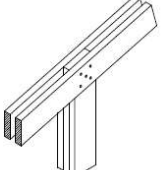
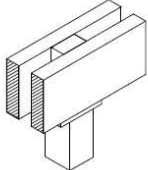
3.4.1 Contact transfer		
Purlin or batten to beam 	Truss node 	Rafter to a column 
Beam to post 	Joist to bearer 	Beam to post 
Rafter to a column 	Beam to post 	

The section will be focused heavily on metal fasteners, because of their prominence in wood building construction. For each connection method, information will also be provided on the appearance of the connection. Connection details will be provided, including details for connecting wood to wood, and to other major building materials. This section will be arranged according to the topics listed below:

- 3.7.1. Light connections
 - 3.7.1.1. Nails
 - 3.7.1.2. Screws
 - 3.7.1.3. Framing connectors
- 3.7.2. Heavy connections (from intro to wood building tech)
 - 3.7.2.1. Bolts
 - 3.7.2.2. Lag Screws
 - 3.7.2.3. Timber Rivets
 - 3.7.2.4. Examples of Mass timber connections

- 3.7.3. Timber joinery
- 3.7.4. Adhesives
- 3.7.5. Connection details
 - 3.7.5.1. Wood to wood
 - 3.7.5.2. Wood to masonry/concrete
 - 3.7.5.3. Wood to steel
- 3.7.6. Opportunities for CNC milling
- 3.7.7. Applicable standards

3.8 Shrinkage in wood frame buildings

This section reminds the reader about key points made earlier about the effects of wood shrinkage in buildings. The section will provide examples of different types of lumber products and their shrinkage characteristics. The equilibrium moisture content of wood and how this can mitigate shrinkage will also be described.

A description of the effect of shrinkage on fasteners will also be included, in addition to common defects resulting from shrinkage, such as nail popping. General recommendations to reduce these potential defects will be described. Another section dedicated to the effects of shrinkage in multi-storey wood frame buildings will be included. For high wood buildings, shrinkage of the wood frame is an important consideration in the design of the structures. The section will describe the importance of evaluating the shrinkage of a building's wood frame in four major areas:

- 3.8.1. where non-uniform shrinkage may occur
- 3.8.2. where metal connections are used to support large solid sawn timber or glue-laminated timber
- 3.8.3. where shrinkage could cause distress to the finish material
- 3.8.4. where shrinkage could cause distress in plumbing, electrical and mechanical systems

Sub-sections will also be dedicated to specific details unique to high wood buildings:

- 3.8.5. Elevator shafts of concrete or masonry, connected to wood framed structures
- 3.8.6. Steel post balconies connecting to wood frame structures.

3.9 Integrating Mechanicals

This section will contain an overview of the considerations that must be given when designing for plumbing, electrical, heating and ventilation in wood-frame buildings. A sub-section on integrating rooftop renewables will also be included. The benefits of BIM will be mentioned here, as a powerful tool that allows multi-discipline sharing and clash detection.

Specific details and specifications for mid-rise and high-rise buildings will be highlighted. In addition, this section will also contain emphasis of engineered specified details for the mid-rise and high-rise buildings.

- 3.9.1. Integrating heating systems
- 3.9.2. Integrating ventilating
- 3.9.3. Integrating plumbing
- 3.9.4. Integrating rooftop renewables

3.10 Typical framing details

This section will provide typical framing details for light wood, heavy timber, post and beam, and mass timber structural systems. The sub-section on light wood framing details will be arranged from the 'ground' and up: floor framing, columns, beams, joists, walls, and roof framing.

For heavy timber, and post and beam details, a sub-section will be provided that illustrates how to design details that account for dimensional change. This includes the arrangement of framing members and detailing connections.

- 3.10.1. Light wood framing details
 - 3.10.1.1. Floor framing
 - 3.10.1.2. Columns
 - 3.10.1.3. Beams
 - 3.10.1.4. Wood joists
 - 3.10.1.5. Wall framing
 - 3.10.1.6. Roof framing
 - 3.10.1.7. Shearwall and Diaphragms
- 3.10.2. Heavy timber, and Post and Beam details
 - 3.10.2.1. Detailing for dimensional change
- 3.10.3. Mass timber details
- 3.10.4. Examples for controlling shrinkage and differential movement

3-D Examples of Content

Specific examples have been provided in each section, where applicable.

Reference material

Anderson, L.O. *Wood-Frame House Construction*. U.S Department of Agriculture: Washington, 1975

APA – The Engineered Wood Association. *Building for High Wind Resistance in Light-Frame Wood Construction*. APA – The Engineered Wood Association, 2015

Burrows, John. *Canadian Wood-frame House Construction*. Canada Mortgage and Housing Corporation: Canada, 2013

Canadian Wood Council. *Introduction to Wood Building Technology*. Canadian Wood Council: Ottawa, 1997

Canadian Wood Council. *Wood Design Manual*. Canadian Wood Council: Ottawa, 2005

Canadian Wood Council. *Wood Reference Handbook*. Canadian Wood Council: Ottawa, 2000

Cecobois. *Guide technique sur la conception de bâtiments de 5 ou 6 étages à ossature légère en bois*. Cecobois: 2016

Coulbourn Consulting. *Residential Structural Design Guide*. U.S. Department of Housing and Urban Development Office of Policy Development and Research: 2017

Karacabeyli, Erol, and Lum, Conroy. *Technical Guide for the Design and Construction of Tall Wood buildings in Canada*. FP Innovations, 2014

Keenan, F.J. *Limit States Design of Wood Structures*. Morrison Hershfield Limited: 1986

McLain, Richard, and Steimle, Doug. *Accommodating Shrinkage in Multi-Story Wood-Frame Structures*. WoodWORKS: 2019

Mid-Rise Best Practice Guide: Proven Construction Techniques for five- and six-storey wood-frame builders. Wood-WORKS BC, Canadian Wood Council: 2018

Ministry of Natural Resources and Forestry, and Ministry of Municipal Affairs. *Ontario's Tall Wood Building Reference*. Ministry of Natural Resources and Forestry, and Ministry of Municipal Affairs: 2017

Plank and Beam Framing for Residential Buildings. American Wood Council: 2003

Sandink, Dan, et. al. *Increasing High Wind Safety for Canadian Homes: A Foundational Document for Low-Rise Residential and Small Buildings*. Institute for Catastrophic Loss Reduction: April 2019

Tingley, Dan. *Wood Construction Systems*. Forest and Wood Products Australia: 2018

Outline Part 4: Building Envelope

4-A Complexity, benefit, cost and time analysis

Complexity	Moderate	Information is readily available
Benefit	Moderate	
Cost	Moderate	Information is readily available
Time required		

4-B Proposed Outline

	Content – Part 4 Building Envelope	References	SC recommended
4.1	Introduction: Building envelopes in Canada	6, 25	
	4.1.1 Climate considerations and environmental loads		
4.2	House-as-a-system	24	
4.3	Thermal insulation	6, 25	Yes
	4.3.1. Controlling heat flow <ul style="list-style-type: none"> 4.3.1.1. Solar control 4.3.1.2. Minimizing conductive losses 4.3.1.3. Minimizing air leakage 4.3.2. Thermal insulation strategies <ul style="list-style-type: none"> 4.3.2.1. Interior insulated 4.3.2.2. Exterior insulated 4.3.2.3. Split insulation 4.3.3. Insulation material – thermal resistance tables, pros and cons <ul style="list-style-type: none"> 4.3.3.1. Effectiveness of different insulation materials 4.3.3.2. Application considerations 4.3.3.3. Tall building applications 4.3.3.4. Different insulation materials and moisture 4.3.3.5. Different insulation materials and fire 4.3.4 Structure and Insulation details <ul style="list-style-type: none"> 4.3.4.1. Insulating wood buildings: Common assemblies and their thermal resistances 4.3.4.2. Insulating post and beam timber construction 4.3.4.3. Log buildings 4.3.4.4. Ice damming 4.3.4.5. Impacts of thermal bridging caused by framing 4.3.4.6. Thermal mass effects of heavy timber framing 4.3.4.7. Spray foam and stud shrinkage 		
4.4	Moisture Control		Yes
	4.4.1. Sources of moisture 4.4.2. Moisture movement 4.4.3. Rain penetration 4.4.4. Vapour diffusion 4.4.5. Ground water 4.4.6. Precautions for protection of materials on the job site		

	<ul style="list-style-type: none"> 4.4.6.1 Durability 4.4.6.2. Moisture storage and dissipation 4.4.6.3. Managing lumber with a high moisture content 4.4.7. Moisture deflection <ul style="list-style-type: none"> 4.4.7.1. Air barriers and air barrier systems 4.4.7.2. Vapour diffusion retarders 4.4.7.3. Rainscreen principles 4.4.8. Drainage 4.4.9. Drying 		
4.5	Air, Vapour and weather barriers		
	<ul style="list-style-type: none"> 4.5.1. Air and vapour barriers <ul style="list-style-type: none"> 4.5.1.1. How vapour barriers work 4.5.1.2. Double vapour barrier concept 4.5.1.3. Air barriers as weather barriers and why their fail 4.5.1.4. Assembly details 4.5.2. Appropriate Air Barrier Systems for tall wood buildings <ul style="list-style-type: none"> 4.5.2.1. Exterior-insulated mass timber panel 4.5.2.2. Avoiding Wood-Frame Infill Wall for Wood Post-and-Beam Construction 4.5.3. Rainscreen principle <ul style="list-style-type: none"> 4.5.3.1. Moisture content considerations 4.5.3.2. Definitions and descriptions 4.5.3.3. Depth of air spaces 4.5.3.4. Application considerations 4.5.4. Cladding and cladding attachments <ul style="list-style-type: none"> 4.5.4.1. Wood siding grades, sizes, patterns, nailing patterns 4.5.4.2. Shingles and shakes, grades, treatments 4.5.4.3. Softwood plywood 4.5.4.4. Oriented Strandboard Panels 4.5.4.5. Structural adhesives: EIFS 4.5.4.6. Long screws through exterior insulation 4.5.4.7. Metal clips 4.5.4.8. Masonry ties and shelf angles 4.5.4.9. Intermittent Thermal Spacers 4.5.4.10. Continuous Wood Framing 4.5.5. Application 	5, 25	Yes
4.6	Managing wood shrinkage		
	<ul style="list-style-type: none"> 4.6.1. Managing dimensional change <ul style="list-style-type: none"> 4.6.1.1. Ceiling-partition separation 4.6.1.2. Nail popping 4.6.2. Compatibility with other materials 4.6.3. Balconies and Horizontal Projections 4.6.4. Window flashing 4.6.5. Elevator cores with wood framing and detailing for movement 	6, 25, 41	Yes
4.7	Fenestration Selection and Installation considerations		
	<ul style="list-style-type: none"> 4.7.1. Window materials 4.7.2. Window standards <ul style="list-style-type: none"> 4.7.2.1. Air leakage 4.7.2.2. Water leakage 	5	

	<ul style="list-style-type: none">4.7.2.3. Wind load resistance4.7.3. Heat loss and gain through windows<ul style="list-style-type: none">4.7.3.1. Window panes and energy loss reduction4.7.4. Thermal resistance of windows4.7.5. Condensation on windows4.7.6. Curtain walls and window wall systems4.7.7. Exterior doors4.7.8. Installation considerations		
--	--	--	--

4-C Content

4.1 Introduction: Building envelopes in Canada

This section will contain an updated description of the evolution of the building envelope in Canada, based on, “Wood-Frame Envelopes: Best Practice Guide Building Technology,” publication. This will not be a full building science text book summary, but rather concentrate specifically demonstrating how wood assemblies perform well if detailed well, and what happens when the details are insufficient.

4.1.1 Climate considerations and environmental loads

Climate considerations are particularly important for building enclosures in Canada. This section will provide specific recommendations for constructing wood-frame enclosures in climate zones 4 and above.

This section will provide the definition of heating degree days and climate zones, and how they determine energy or thermal performance requirements. An overview of the climate zones applicable to Canada will be provided, with various figures (sample below, from *Guide to Designing Energy-Efficient Building Enclosures*, to be revised to show the Canadian map with 7A and 7B).

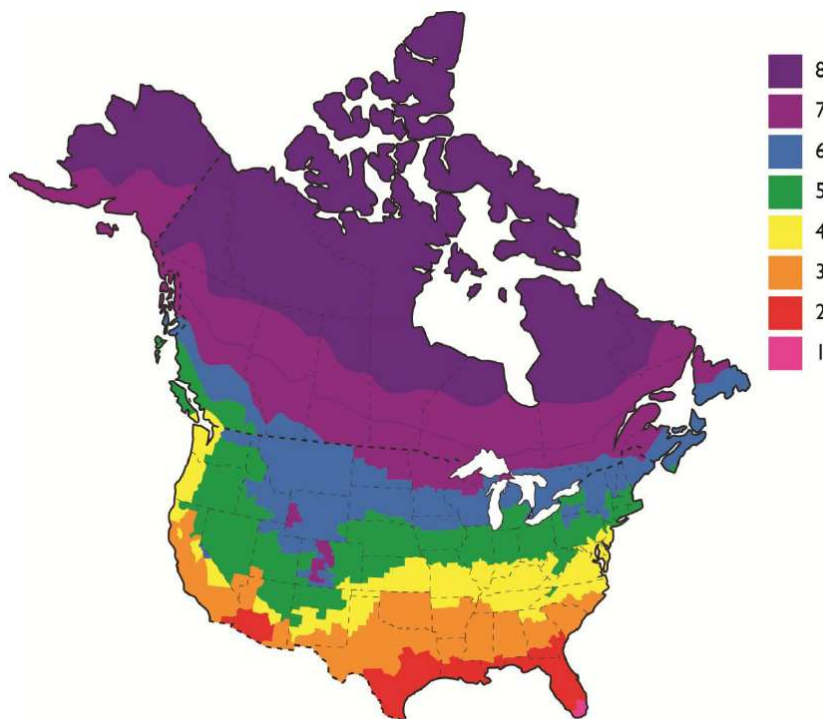

Fig. 2.4.4 ASHRAE climate zone map, based on current U.S. IECC/DOE and Canadian Climate Zones 1 to 8.

4.2 House-as-a-system

This section will introduce the ‘house as a system’ building science concept. This section will reference the Canadian Home Builders’ Association Builders’ Manual material on the house-as-a-system concept. The section will list the components within a house that have an effect on the overall system, the individual characteristics of these components, and how they can affect the performance of the house as a whole. To better illustrate the concept, an example will be used.

4.3 Thermal insulation

This section will focus specifically with temperature control aspect of the building envelope. This section will reference BCHousing's "R22+ Effective Walls in Residential Construction in BC," and "R30+ Effective Vaulted and Flat Roofs in Residential Construction."

To begin, the three mechanisms of heat flow will be discussed. Subsequent topics will be presented in the order provided below:

- 4.3.1. Controlling heat flow
 - 4.3.1.1. Solar control
 - 4.3.1.2. Minimizing conductive losses
 - 4.3.1.3. Minimizing air leakage
- 4.3.2. Thermal insulation strategies
 - 4.3.2.1. Interior insulated
 - 4.3.2.2. Exterior insulated
 - 4.3.2.3. Split insulation
- 4.3.3. Insulation material – thermal resistance tables, pros and cons
 - 4.3.3.1. Effectiveness of different insulation materials
 - 4.3.3.2. Application considerations
 - Storage and handling
 - Manufacturer instructions
 - 4.3.3.3. Tall building applications
 - 4.3.3.4. Different insulation materials and moisture
 - 4.3.3.5. Different insulation materials and fire
- 4.3.4 Structure and Insulation details
 - 4.3.4.1. Insulating wood buildings: Common assemblies and their thermal resistances
 - 4.3.4.2. Insulating post and beam timber construction
 - 4.3.4.3. Log buildings
 - 4.3.4.4. Ice damming
 - 4.3.4.5. Impacts of thermal bridging caused by framing
 - 4.3.4.6. Thermal mass effects of heavy timber framing
 - 4.3.4.7. Spray foam and stud shrinkage

Figure 6.12
Cathedral
ceiling

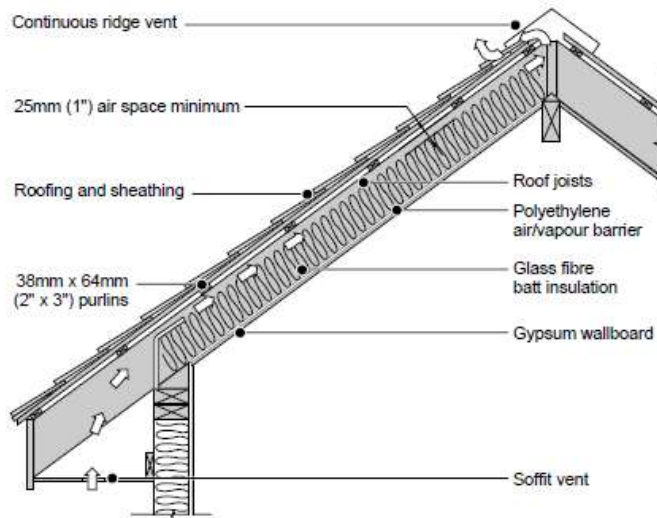

Material	Thermal resistance	
	RSI	R
Interior air film	0.11	0.6
12.7mm (1/2") gypsum wallboard	0.08	0.4
Air/vapour barrier	0.00	0.0
178mm (7") glass fibre batt insulation	4.20	24
Enclosed air films	0.22	1.2
15.5mm (5/8") plywood or OSB sheathing	0.13	0.8
Asphalt shingles	0.078	0.4
Exterior air film	0.03	0.15
Total	4.85	27.6

4.4 Moisture Control

This section will introduce moisture control concepts for wood-frame building envelopes. The section will begin by covering some introductory topics, listed below:

- 4.4.1. Sources of moisture
- 4.4.2. Moisture movement
- 4.4.3. Rain penetration
- 4.4.4. Vapour diffusion
- 4.4.5. Ground water

The section will then describe how to design building enclosure to protect against all the mentioned sources of moisture. The section will cover the following protection concepts using the “deflection, drainage, drying and durability,” principles. The section will include the following:

- 4.4.6. Precautions for protection of materials on the job site
 - 4.4.6.1 Durability
 - 4.4.6.2. Moisture storage and dissipation
 - 4.4.6.3. Managing lumber with a high moisture content
- 4.4.7. Moisture deflection

- 4.4.7.1. Air barriers and air barrier systems
- 4.4.7.2. Vapour diffusion retarders
- 4.4.7.3. Rainscreen principles
- 4.4.8. Drainage
- 4.4.9. Drying
 - Vapour barriers case study: Case study on the Vancouver’s “Leaky condo crisis,” where buildings were damaged by rainwater infiltration, with an estimated \$4 billion in damage. This section will describe what went wrong and how the code or proper design and detailing could help prevent a similar situation from reoccurring.

4.5 Air, vapour and weather barriers

This section will cover how air, vapour and weather barriers control moisture movement in buildings. For air and vapour barriers, component and material specifications will be included. Applicable performance standards will also be included. This section will follow the Introduction to Wood Building Technology book. A sample of the figures that could be included are provided below.

Table 7.1
Perm rating
of building
materials

Material	Perm rating ⁽¹⁾	
Sheathing (low insulation value)	12.7mm (1/2") foil-faced gypsum board	Negligible
	6.4mm (1/4") plywood	23 – 74
	12.7mm (1/2") gypsum board sheathing	1373
	11mm (7/16") oriented strandboard (OSB)	44
	11mm (7/16") fibreboard sheathing	772 – 2465
	17mm (2/3") wood sheathing	982
Insulation	25mm (1") foil-faced urethane	Negligible
	25mm (1") extruded polystyrene	23 – 92
	25mm (1") urethane foam	69
	25mm (1") phenolic foam	133
	25mm (1") expanded polystyrene (type 2)	86 – 160
	Fibrous insulations	Very high
Membrane Materials	Metal	Negligible
	0.15mm (0.006") polyethylene	1.6 – 5.8
	Breather type sheathing membrane	170 – 1400
	Spun bonded polyolefin film	3646

Notes:

1. Perm ratings are derived from:
 - Bombaru, D., Jutras, R., and Patenaude, A. Air Permeance of Building Materials. Summary report prepared by, AIR-INS Inc. for Canada Mortgage and Housing Corporation, Ottawa, 1988.
 - The Details of Air Barrier Systems for Houses. Ontario New Home Warranty Program, Don Mills, 1993.
2. One metric perm represents one nanogram of water per second per square metre of material under a pressure of one Pascal (1 metric perm = 1ng/(Pa • s • m²)).

Table 7.2
Measured air permeability of building materials

Material		Air permeability ⁽²⁾ L/(s·m ²)
Sheathing (low insulation value)	12.7mm (1/2") foil-faced gypsum board	Negligible
	6.4mm (1/4") plywood	0.0084
	12.7mm (1/2") gypsum board sheathing	0.0091
	11mm (7/16") oriented strandboard (OSB)	0.0108
	11mm (7/16") fibreboard sheathing	0.8285
	17mm (2/3") wood sheathing	High – depends on no. of joints
Insulation	25mm (1") foil-faced urethane	Negligible
	25mm (1") extruded polystyrene	Negligible
	25mm (1") urethane foam	Negligible
	25mm (1") phenolic foam	Negligible
	25mm (1") expanded polystyrene (type 2)	0.0214
	Fibrous insulations	Very high
Membrane Materials	Metal	Negligible
	0.15mm (0.006") polyethylene	Negligible
	Breather type sheathing membrane	0.2706
	Spun bonded polyolefin film	0.9593

Notes:

1. Air permeability values are derived from:

- Bombaru, D., Jutras, R., and Patenaude, A. Air Permeance of Building Materials. Summary report prepared by, AIR-INS Inc. for Canada Mortgage and Housing Corporation, Ottawa, 1988.
- The Details of Air Barrier Systems for Houses. Ontario New Home Warranty Program, Don Mills, 1993.

2. Air Permeability is measured at 75 Pa.

This section will also cover appropriate air barrier systems that could be used for tall wood buildings.

A final subsection will present wood cladding products as part of the weather barrier, including strategies, products and techniques for cladding attachments that do not compromise the thermal performance of wood frame wall assemblies. The arrangement of the topics is listed below:

- 4.5.1. Air and vapour barriers
 - 4.5.1.1. How vapour barriers work
 - 4.5.1.2. Double vapour barrier concept
 - 4.5.1.3. Air barriers as weather barriers and why they fail
 - 4.5.1.4. Assembly details
- 4.5.2. Appropriate Air Barrier Systems for tall wood buildings
 - 4.5.2.1. Exterior-insulated mass timber panel
 - Cladding support
 - Air and vapour barriers
 - 4.5.2.2. Avoiding Wood-Frame Infill Wall for Wood Post-and-Beam Construction
- 4.5.3. Rainscreen principle
 - 4.5.3.1. Moisture content considerations
 - 4.5.3.2. Definitions and descriptions
 - Ventilated versus vented
 - Pressure equalization
 - Compartmentalization

- 4.5.3.3. Depth of air spaces
- 4.5.3.4. Application considerations
 - Vertical siding with strapping
 - Mortar droppings and other blockages
- 4.5.4. Cladding and cladding attachments
 - 4.5.4.1. Wood siding grades, sizes, patterns, nailing patterns
 - 4.5.4.2. Shingles and shakes, grades, treatments
 - 4.5.4.3. Softwood plywood
 - 4.5.4.4. Oriented strand board panels
 - 4.5.4.5. Structural adhesives: EIFS
 - 4.5.4.6. Long screws through exterior insulation
 - 4.5.4.7. Metal clips
 - 4.5.4.8. Masonry ties and shelf angles
 - 4.5.4.9. Intermittent Thermal Spacers
 - 4.5.4.10. Continuous Wood Framing
- 4.5.5. Application
 - Rain penetration case studies and examples: deck ledgers, windows and illustration of correct and incorrect methods of installation)

Sample figures and tables are provided below:

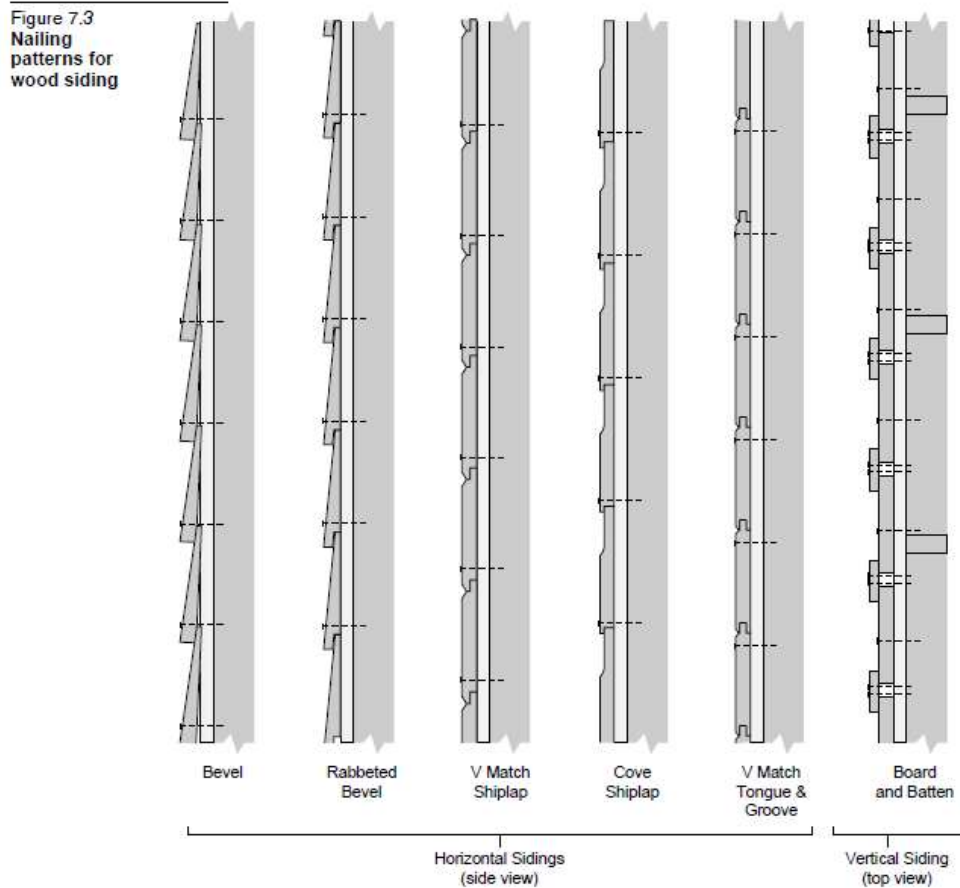

Table 7.5
Typical grades
for exterior
cladding

Grade category	Category description	Grades	Principal characteristics
Finish, Paneling, Ceiling and Drop Siding	This category is usually dressed four sides and kiln dried.	Clear heart	Highest quality for top quality appearance, many pieces are absolutely clear.
		A	Very good appearance but allows some small imperfections.
		B	Good appearance, many pieces have a fine appearance on one side and larger or more numerous growth characteristics on the back side.
Bevel Siding	This category is made by resawing kiln dried surfaced lumber on a bevel to produce two beveled pieces. Most commonly used for exterior siding.	Clear heart	Intended for highest quality applications, exposed width is all heartwood and free from imperfections.
		A	Very good appearance with some small imperfections permitted.
		B	This grade, permitting small imperfections and two or less cutouts, is a good quality siding where a painted surface is required.
		Rustic	This grade has a rough finish on the better side and is used as a sidewall covering where a rustic appearance is desired.
Tight-knotted Stock, Rough or Dressed Knotty Paneling and Siding	Knots and other markings are the distinguishing characteristics of this grade category.	Select knotty	Good quality siding with a knotty appearance. Knots are tight and small.
		Quality knotty	Larger knots are permitted and some may be loose or unsound.
Knotty Bevel Siding	This is like the preceding grade category except the siding is beveled.	Select knotty	see above
		Quality knotty	see above

Notes:

1. The grades in each of these categories are not stress-graded but are graded according to the appearance of the better face. The reverse side often has characteristics approximately one grade lower than the face.

Air barrier details for tall buildings:

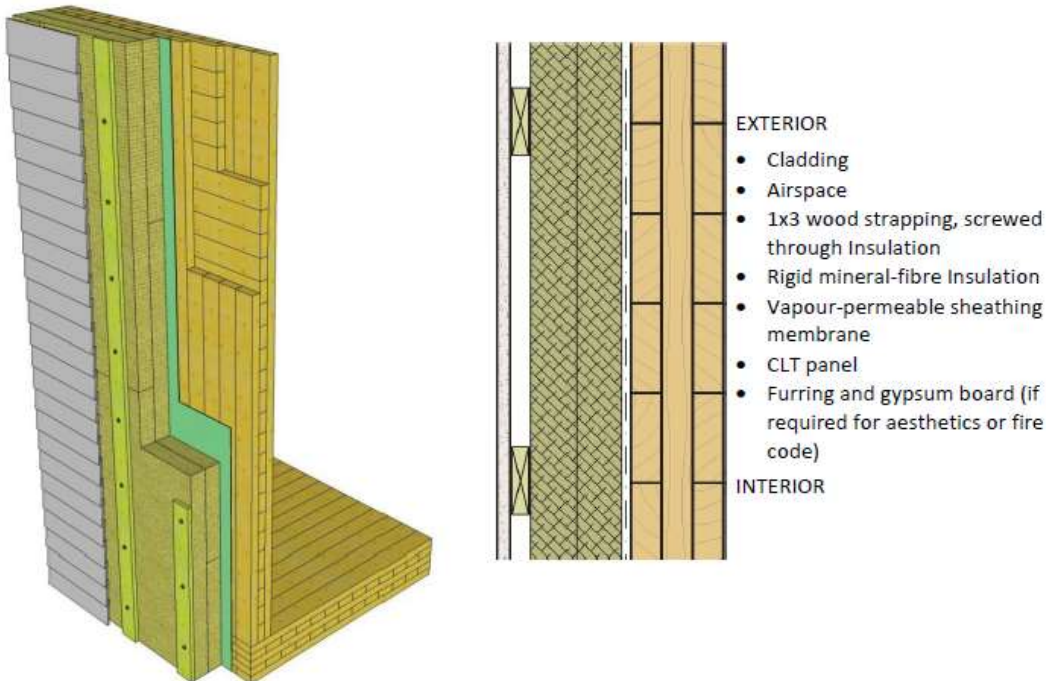

Fig. 4.3.1 Exterior-insulated mass timber panel assembly (isometric sketch and plan view detail).

4.6 Managing Wood shrinkage

This section addresses the issue of dimensional change and how to manage wood shrinkage in wood buildings. This section will examine how to design for dimensional change, and the compatibility of wood framing with materials that have different characteristics.

A sub-section will present design considerations as they relate to balconies, decks, porches and other horizontal projections. The section will include information that will inform the loads and sizing of framing members. Typical details with checklists of considerations will be presented (sample pages below). There will be an emphasis placed on the specified slopes of balconies, with consideration given to accommodating settlement.

The arrangement of topics in this section is listed below:

- 4.6.1. Managing dimensional change
 - 4.6.1.1. Ceiling-partition separation
 - 4.6.1.2. Nail popping
- 4.6.2. Compatibility with other materials
- 4.6.3. Balconies and horizontal projections
- 4.6.4. Window flashing
- 4.6.5. Elevator cores with wood framing and detailing for movement

BALCONIES

COLUMN-SUPPORTED BALCONY WITH BRICK VENEER-WALL ASSEMBLY A-DETAIL 23

Notes

- The use of a column-supported balcony is preferable to a cantilever because joists do not extend through the wall sheathing and air barrier.
- Balcony joists are supported on a ledger bolted to the framing.
- Air-barrier continuity at the floor level may be achieved by typical wall assembly details.
- A rubberized asphalt membrane is installed behind the ledger to protect the sheathing from water and to seal around penetrations of the sheathing.
- The wood ledger is protected from wetness in the cavity by a through-wall flashing.
- The through-wall flashing is extended approximately 100 mm (4 in.) from the brick face to keep water away from the wall face, where it may enter through openings.
- A gap is left around the balcony joists where they penetrate the brick veneer to allow for differential movement. The gap is sealed with caulking and back-up rope.
- A through-wall flashing is provided below the balcony so that any water leaking into the assembly is led back out of the wall.

Designer's Checklist

- Ensure that the balcony column structure will exhibit the same cumulative shrinkage characteristics as the main wall, or allow for predicted shrinkage so that there will be drainage away from the wall.
- Locate the balcony door sill above through-wall flashing.
- Specify a brick cavity wide enough to accommodate the wood ledger.
- Specify pressure-treated wood for joists and cedar or treated wood for decking.
- Design the structural connection of the balcony to meet the load criteria.

Builder's Checklist

- Verify the foundation and framing layout to ensure that a proper wall cavity is allowed for.
- Install a self-adhesive membrane before framing the balcony.
- Coordinate the installation of through-wall flashing and protection membrane with the tradespeople.

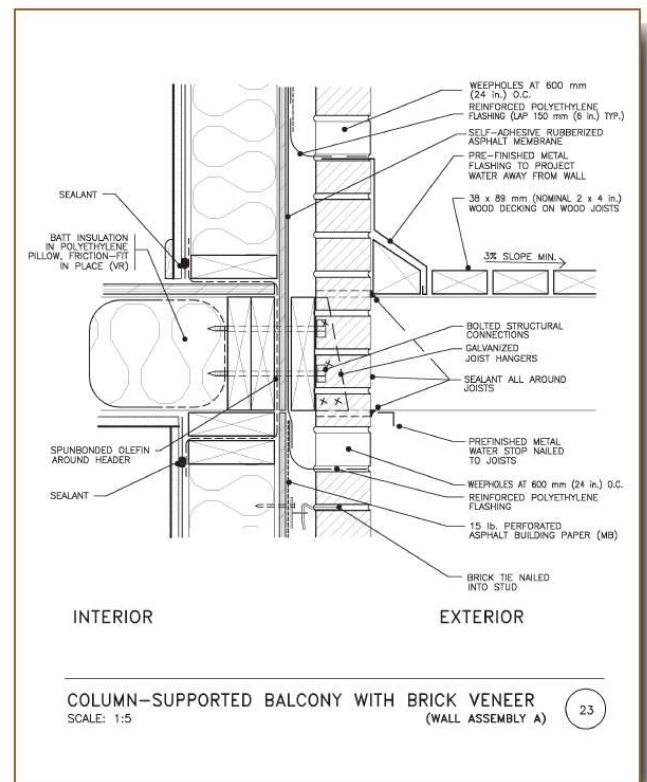

Detail 23: Column-Supported Balcony with Brick Veneer

4.7 Fenestration Selection and Installation considerations

This section will present the impact fenestration has on the overall thermal resistance of the building envelope, air leakage and moisture control. The different window types for low- and high-rise buildings will be presented. Installation considerations and sequences will also be presented in this section, including the continuity of insulation, air barriers and vapour barriers. Additional topics are listed below, from the Introduction to Wood Building Technology reference book:

- 4.7.1. Window materials
- 4.7.2. Window standards
 - 4.7.2.1. Air leakage
 - 4.7.2.2. Water leakage
 - 4.7.2.3. Wind load resistance
- 4.7.3. Heat loss and gain through windows
 - 4.7.3.1. Window panes and energy loss reduction
 - Even the best quality windows will affect the overall wall thermal efficiency
- 4.7.4. Thermal resistance of windows (related to 4.7.3)
- 4.7.5. Condensation on windows
- 4.7.6. Curtain walls and window wall systems
 - Examples: Brock Commons and 80 Atlantic Avenue
- 4.7.7. Exterior doors
- 4.7.8. Installation considerations
 - This subsection will contain detailed graphics illustrating how to install windows properly, using various flashing products.

Reference Material

BC Housing. *Illustrated Guide – R22+ Effective Walls in Residential Construction in BC*. BC Housing, 2019

BC Housing. *Illustrated Guide – R30+ Effective Vaulted & Flat Roofs in Residential Construction*. BC Housing, 2019

Burrows, John. *Canadian Wood-frame House Construction*. Canada Mortgage and Housing Corporation: Canada, 2013

Canada Mortgage and Housing Corporation. *Wood-Frame Envelopes: Best Practice Guide Building Technology*. Canada Mortgage and Housing Corporation, 2004

Canadian Home Builders' Association. *CHBA Builders' Manual*. Canadian Home Builders' Association: Ottawa, 2013

Canadian Wood Council. *Introduction to Wood Building Technology*. Canadian Wood Council: Ottawa, 1997

Finch, Graham, Wang, Jieying, and Ricketts, Dave. *Guide for Designing Energy-Efficient Building Enclosures for Wood-Frame Multi-Unit Residential Buildings in Marine to Cold Climate Zones in North America*. Homeowner Protection Office, Canadian Wood Council: 2013

Prescriptive Residential Wood Deck Construction Guide. American Wood Council: 2015

Ricketts, Lorne. *Illustrated Guide: R22+ Effective Walls in Wood-Frame Construction in British Columbia*. BC Housing, 2017

Outline Part 5: Fire and Sound Control

5-A Complexity, benefit, cost and time analysis

Complexity	Moderate	Information is readily available
Benefit	High	
Cost	Moderate	Information is mostly readily available
Time required		Additional research is required for Section 5.7

5-B Proposed Outline

	Content – Part 5 Fire	References	SC recommended
5.1	Fire Safety - low-rise/mid-rise/tall wood		
	5.1.1. National Fire Protection Association (NFPA) fire safety concepts tree 5.1.2. Fire safety design in low and mid-rise buildings 5.1.3. Fire safety design in tall mass timber buildings 5.1.4. Differences in NFPA13 and NFPA13R	4, 5	
5.2	Protection		
	5.2.1. Fire separations 5.2.1.1. Protection of small openings 5.2.1.2. Firewalls 5.2.2. Fire resistance ratings 5.2.2.1. Vertical assemblies 5.2.3. Fire protection requirements for mezzanines and atriums 5.2.4. Fire stops	4	Yes
5.3	Charring	42	
5.4	Assemblies - FRR		
	5.4.1. Determining Fire-resistance ratings 5.4.2. Continuity of fire separations 5.4.3. Type of gypsum wallboard 5.4.4. Fasteners for protective membranes in fire-rated assemblies 5.4.5. Size and spacings of structural members 5.4.6. Roof and floor fire-resistance ratings 5.4.7. Wall fire-resistance ratings 5.4.8. Fire resistance ratings of loadbearing elements	5	Yes
5.5	Penetrations		
	5.5.1. Conduit and cables 5.5.2. Electrical boxes, receptacles, and outlets 5.5.3. Duct Penetrations 5.5.4. Pipe Penetrations 5.5.5. Window openings and proper methods of calculations	5	Yes
5.6	Sprinkler protection		
	5.6.1. Provision of sprinklers	5	

	<p>5.6.2. Concealed spaces</p> <p>5.6.3. Double joist or stud spaces</p> <p>5.6.4. Wood bar joist and truss construction</p> <p>5.6.5. Wood joist construction</p> <p>5.6.6. Wood I-joist construction</p> <p>5.6.7. Small isolated rooms</p> <p>5.6.8. Attics, roof spaces, floor and ceiling spaces and crawl spaces</p> <p>5.6.9. Limited combustible materials in concealed spaces</p> <p>5.6.10. Sprinkler protection in special situations</p> <p>5.6.11. Stairways</p> <p>5.6.12. Small rooms or spaces in residential construction</p>		
5.7	Protecting fasteners and connections	4, additional research required	
5.8	Transmission - how it works	5	
	<p>5.8.1 The physics of sound</p> <p>5.8.2 Behaviour of sound in buildings</p> <p>5.8.3 Sound transmission loss</p> <p>6.1.3.1 Mass law</p> <p>6.1.3.2 Double layer assemblies</p> <p>6.1.3.3 Gypsum wallboard surfaced assemblies</p> <p>6.1.3.4 Acoustical properties of wood</p>		
5.9	STC/IIC/ASTC	5, 19	
	<p>5.9.1 Sound testing of walls and floors</p> <p>5.9.2 What is sound transmission class?</p> <p>5.9.3 What is impact insulation class?</p> <p>5.9.4 Sound control and National Building Code requirements</p> <p>5.9.5 Best practices and minimum ratings for sound control</p> <p>5.9.6 SoundPATHS application demonstration</p>		
5.10	Sound ratings of wood assemblies	5	Yes
5.11	Isolation techniques	19	Yes
	<p>5.11.1. Steps to controlling sound transmission</p> <p>5.11.2. Barriers to the passage of sound</p> <p>5.11.3. Sound control in wall assemblies</p> <p>6.4.3.1. Integrating services</p> <p>6.4.3.2. Assembling and integrating components</p> <p>5.11.4. Sound control in floors</p> <p>6.4.4.1. Joist and truss floors</p> <p>6.4.4.2. Reducing impact noise</p> <p>6.4.4.3. Reducing impact sound with floating floors</p> <p>6.4.4.4. Reducing flanking noise and other unintended sounds</p>		
5.12	Details	19	Yes

5-C Content

5.1 Fire safety and General information

This section will contain information that introduces the concepts of fire safety design. It will start by introducing the three types of construction: Combustible, Non-combustible, and Encapsulated mass timber. This will include a section on the history of fire performance and wood buildings, and why catastrophes of the past cannot occur in present day.

It will then explain the importance of protecting against construction fires, and refer the reader to subsequent detailed sub-sections.

The applicable standards and building codes as they relate to fire safety. The arrangement of topics in this section is listed below:

- 5.1.1. National Fire Protection Association (NFPA) fire safety concepts tree
- 5.1.2. Fire safety design in low and mid-rise buildings
- 5.1.3. Fire safety design in tall mass timber buildings
- 5.1.4. Differences in NFPA13 and NFPA13R

5.2 Fire Protection

This chapter will explain the methods to achieve the ‘Contain Fire by Construction’ objective required by the NFPA fire safety concepts tree. This chapter will provide information based on the Canadian Wood Council’s “Fire Safety Design in Wood Buildings,” publication and updated free publications from cwc.ca. The arrangement of topics in this section is listed below:

- 5.2.1. Fire separations
 - 5.2.1.1. Protection of small openings
 - 5.2.1.2. Firewalls
- 5.2.2. Fire resistance ratings
 - 5.2.2.1. Vertical assemblies
- 5.2.3. Fire protection requirements for mezzanines and atriums
- 5.2.4. Fire stops

5.3 Charring – mass timber construction

This section will explain the fire performance of mass timber construction, specifically in relation to the char rate and depth. This section will refer to the standard CAS O85, annex B titled, “Fire resistance of large cross-section wood elements.” A sample figure is provided below, from “Ontario’s Tall Wood Building Reference,”:

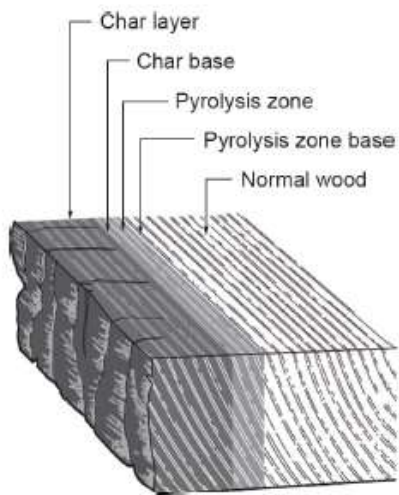

Figure 3.1. Formation of Char layer and pyrolysis zone in wood (one-dimensional) when exposed to high temperatures (CSA, 2011).

5.4 Assemblies – Fire Resistance Ratings

This section will expand on the introductory section from 5.2. This section will provide the definition of the fire resistance ratings and how they are determined. The section will follow the same content layout as provided in the Canadian Wood Council publication, ‘Introduction to Wood Building Technology.’ The topics covered in this chapter is listed below:

- 5.4.1. Determining Fire-resistance ratings
- 5.4.2. Continuity of fire separations
 - This sub-section will also focus especially on assembly -to -assembly detailing that could vary from location to location
- 5.4.3. Type of gypsum wallboard
- 5.4.4. Fasteners for protective membranes in fire-rated assemblies
- 5.4.5. Size and spacings of structural members
- 5.4.6. Roof and floor fire-resistance ratings
- 5.4.7. Wall fire-resistance ratings
- 5.4.8. Fire resistance ratings of loadbearing elements

5.5 Openings and Penetrations

This section will describe how to design service openings and penetrations to maintain the integrity of fire separations. The section will include requirements and illustrations that cover the following topics:

- 5.5.1. Conduit and cables
- 5.5.2. Electrical boxes, receptacles, and outlets
- 5.5.3. Duct Penetrations
- 5.5.4. Pipe Penetrations
- 5.5.5. Window openings and proper methods of calculations
 - This sub-section will include correct code interpretations of window openings for multi-storey buildings.

5.6 Sprinkler protection

This section will cover the installation, protection and design requirements of automatic sprinklers. The requirements outlined in three standards: NFPA 13, 13R, and 13D will be discussed. This section will be based on the 'Introduction to Wood Building Technology,' reference by the Canadian Wood Council. This section will be arranged to include the following topics:

- 5.6.1. Provision of sprinklers
- 5.6.2. Concealed spaces
- 5.6.3. Double joist or stud spaces
- 5.6.4. Wood bar (open-web) joist and truss construction
- 5.6.5. Wood joist construction
- 5.6.6. Wood I-joist construction
- 5.6.7. Small isolated rooms
- 5.6.8. Attics, roof spaces, floor and ceiling spaces and crawl spaces
- 5.6.9. Limited combustible materials in concealed spaces
- 5.6.10. Sprinkler protection in special situations
- 5.6.11. Stairways
- 5.6.12. Small rooms or spaces in residential construction

Sample figures are provided below.

Figure 9.22
Concealed
spaces in
wood bar joist
construction

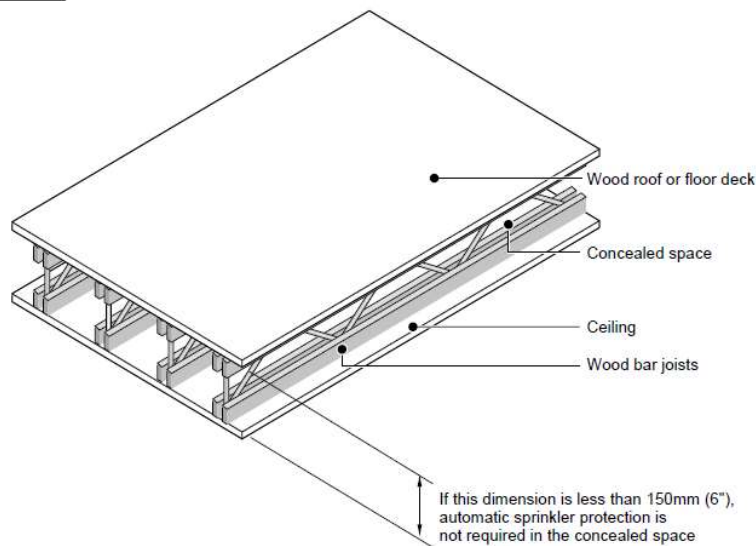

Note:
If the structural members are wood trusses, sprinkler protection is required in every case
(NFPA 13 only).

Figure 9.29
Sprinkler
protection for
noncombustible
stairways

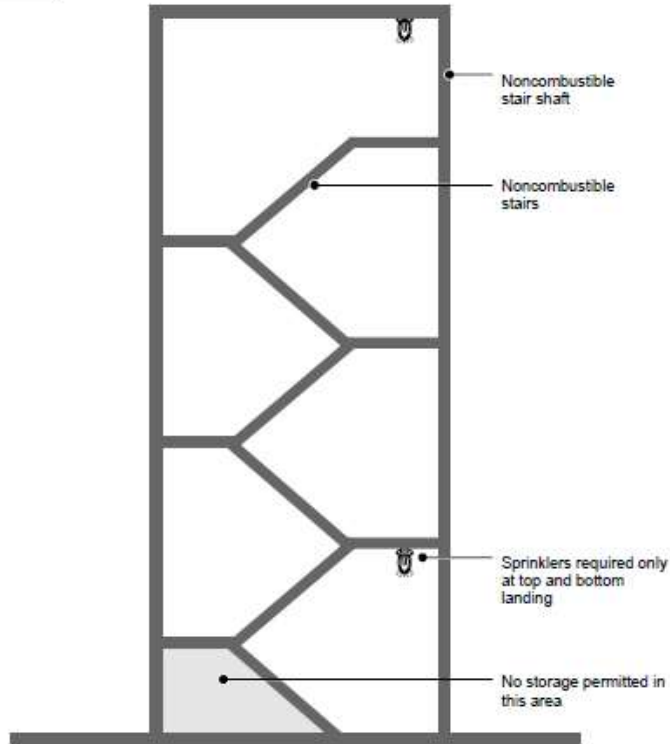
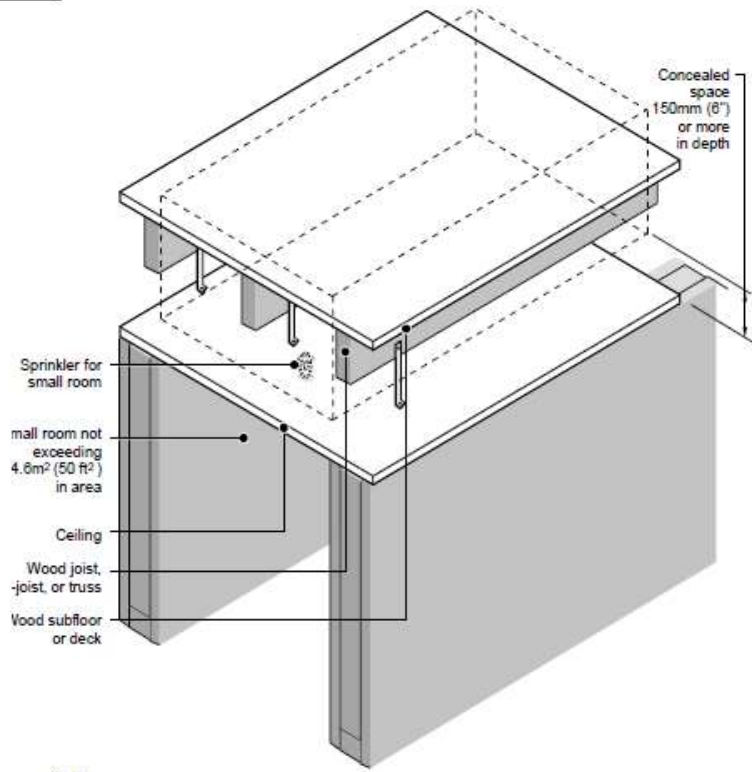

Figure 9.27
Concealed
spaces over
small isolated
rooms



Note:
Dotted line indicates concealed space above small room which is not required to be sprinklered.

5.7 Protecting fasteners and connections

This section will include information on the protection of fasteners and connections used in wood structural systems from fire. This section may require additional research

5.8 Sound Transmission - how it works

This section will describe the mechanisms of sound movement, types of sound, and introduce sound transmission class. This section will reference the CWC publication 'Introduction to Wood Building Technology,' and include the following topics:

- 5.8.1 The physics of sound
- 5.8.2 Behaviour of sound in buildings
- 5.8.3 Sound transmission loss
 - 5.8.3.1 Mass law
 - 5.8.3.2 Double layer assemblies
 - 5.8.3.3 Gypsum wallboard surfaced assemblies
 - 5.8.3.4 Acoustical properties of wood

5.9 STC/IIC/ASTC

This section will include the definitions of sound transmission class (STC), the new measurement called 'Apparent sound transmission class' (ASTC), which combines the direct sound transmission path and flanking sound transmission, and Impact Insulation Class (IIC). The section will present topics in the order described below, referencing the 'Introduction to Wood Building Technology,' and the CMHC's 'Fire and Sound Control in Wood-Frame Multi-Family Buildings.' The last sub-section will present the application SoundPATHS, a web application which predicts sound transmission between rooms.

- 5.9.1 Sound testing of walls and floors
- 5.9.2 What is sound transmission class?
- 5.9.3 What is impact insulation class?
- 5.9.4 Sound control and National Building Code requirements
- 5.9.5 Best practices and minimum ratings for sound control
- 5.9.6 SoundPATHS demonstration
 - <https://nrc.canada.ca/en/research-development/products-services/software-applications/soundpaths-web-application-predict-sound-transmission-between-rooms>

5.10 Sound ratings of wood assemblies

This section will present typical wood assemblies and their sound ratings. The section will include a summary recommended construction practices for installing sound insulating partitions. This section will follow the content as it is presented in the 'Introduction to Wood Building Technology,' reference. Sample figures are provided below.

Figure 8.2
Sound transmission classes (STC) for typical wall assemblies (Source-1995 NBCC)

Section		STC
	<ul style="list-style-type: none"> • 12.7mm (1/2") Type X gypsum wallboard both sides • 38 x 89mm (2" x 4" nom.) studs 400mm (16") or 600mm (24") o.c. 	32
	<ul style="list-style-type: none"> • 12.7mm (1/2") Type X gypsum wallboard both sides • 38 x 89mm (2" x 4" nom.) studs 400mm (16") or 600mm (24") o.c. • Absorptive material 	34
	<ul style="list-style-type: none"> • Double 12.7mm (1/2") Type X gypsum wallboard both sides • Resilient metal channels on at least one side • 600mm (24") o.c. • 38 x 89mm (2" x 4" nom.) studs 400mm (16") o.c. • Absorptive material 	55
	<ul style="list-style-type: none"> • Double 12.7mm (1/2") Type X gypsum wallboard both sides • Two rows 38 x 89mm (2" x 4" nom.) studs 400mm (16") or 600mm (24") o.c. staggered on common 38 x 140mm (2" x 6" nom.) plate • Absorptive material one side 	55
	<ul style="list-style-type: none"> • 12.7mm (1/2") Type X gypsum wallboard both sides • Two rows 38 x 89mm (2" x 4" nom.) studs 400mm (16") or 600mm (24") o.c. on common 38 x 89mm (2" x 4" nom.) plates set 25mm (1") apart • Absorptive material both sides 	57

Figure 8.3
Sound transmission class for typical floor assemblies

Section		STC
	<ul style="list-style-type: none"> • 12.7mm (1/2") finished wood floor • 15.5mm (5/8") wood panel sheathing • Wood floor joists 400mm (16") o.c. • 15.9mm (5/8") gypsum wallboard 	32
	<ul style="list-style-type: none"> • 11mm (1/2") panel sheathing • 15.5mm (5/8") panel sheathing • Wood floor joists 400mm (16") o.c. • Absorptive material • Metal resilient channel 200mm (8") o.c. • 15.9mm (5/8") Type X gypsum wallboard 	50
	<ul style="list-style-type: none"> • 38mm (1-1/2") light weight concrete • 15.5mm (5/8") panel sheathing • Wood floor joists 400mm (16") o.c. • Absorptive material • Metal resilient channel 200 (8") o.c. • 15.9mm (5/8") gypsum wallboard 	60

Note:
Panel sheathing may be plywood or OSB

5.11 Isolation techniques

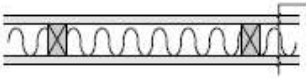
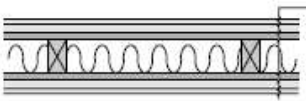
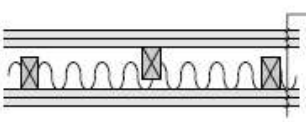
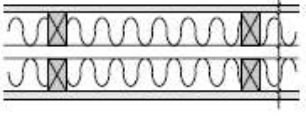
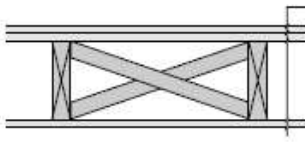
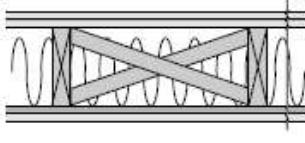
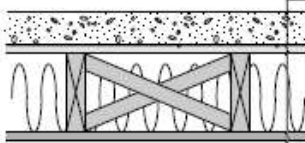
This section will begin by explaining basic techniques to controlling sound transmission in assemblies. Subsequently the section will present assembly specific strategies for sound control. This section will include the following topics.

- 5.11.1. Steps to controlling sound transmission
- 5.11.2. Barriers to the passage of sound
- 5.11.3. Sound control in wall assemblies
 - 5.11.3.1. Integrating services to avoid unwanted sound
 - 5.11.3.2. Assembling and integrating components to avoid unwanted sound
- 5.11.4. Sound control in floors
 - 5.11.4.1. Joist and truss floors
 - 5.11.4.2. Reducing impact noise
 - 5.11.4.3. Reducing impact sound with floating floors
 - 5.11.4.4. Reducing flanking noise and other unintended sounds

5.12 Details

This section will present detail illustrations of ideal assemblies, including notes and explanations. A sample of the detail figures from the CMHC's 'Fire and Sound Control in Wood-Frame Multi-Family Buildings,' reference have been provided below.

The majority of these details will come from the soundPATHS software. Details on flanking and other unintended sound paths due to construction modifications will be included.

WALL AND FLOOR ASSEMBLY DETAILS *Fire and Sound Control in Wood-Frame Multi-Family Buildings*

DETAIL 1—NON-LOADBEARING PARTY WALL

This detail may be used for the walls that separate two dwelling units or apartments in single-storey, multi-family buildings. It could also be used for the walls or floors that separate a unit or apartment from a hall or other common space. The detail shows conventional, non-load-bearing wood-frame wall construction supported on a concrete slab and using double layers of gypsum board with resilient channels on one side.

NOTES

- To avoid flanking noise, do not nail through to the wood framing when attaching baseboards. Similarly, the gypsum board and anything fastened to it must be supported by the resilient channels only and not connected to the underlying frame.
- The fibreboard spacer provides a resilient support for the bottom edge of the gypsum board. Confirm acceptability with the authority having jurisdiction.
- Install a moisture barrier under the concrete slab.
- Apply a bead of acoustical sealant under the bottom wall plate. Apply a bead of caulking between the plate and fibreboard spacer and between the gypsum board and the fibreboard spacer. While not generally as effective, alternatively, a continuous bead of caulking can be applied at the subfloor-bottom plate corner prior to the installation of the fibreboard spacer and between the fibreboard and gypsum board.
- Insulation installed in these assemblies provides important sound attenuation benefits. Fill the entire cavity.
- All electrical penetrations should be tightly fitted and preferably sealed with acoustical caulking. Electrical boxes should be offset by at least 400 mm (16 in.) from boxes on the opposite side of the wall.
- Where possible avoid installing plumbing in these walls or floors.
- The rated wall assembly will need to extend to the underside of the roof sheathing; alternatively, a fire rated ceiling could be used.

WALL AND FLOOR ASSEMBLY DETAILS *Fire and Sound Control in Wood-Frame Multi-Family Buildings*

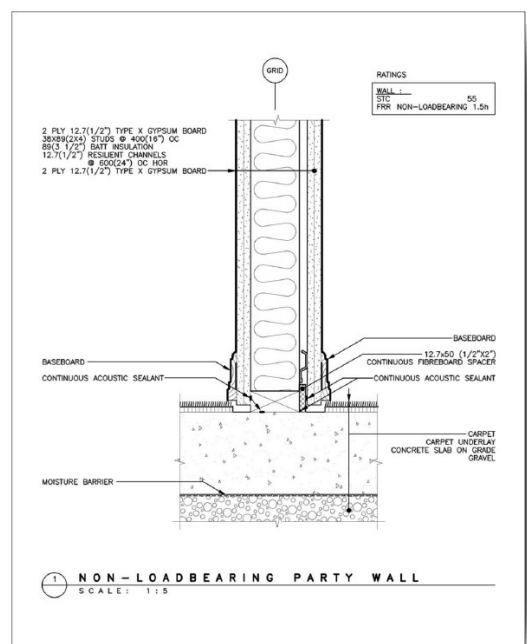

Detail 1: Non-Loadbearing Party Wall

DETAIL 3—LOADBEARING PARTY WALL OR PARTITION

This wood-stud party wall detail is used to separate adjacent dwelling units or apartments. It could also be used for the walls or floors that separate a unit or apartment from a hall or other common space. The detail shows conventional construction with two layers of gypsum board for walls and for ceiling finishes. This approach to construction completely uncouples the two units including each of their structural frames.

NOTES

- Carpet underlay within the floor assembly provides improved impact sound insulation.
- Apply a bead of acoustical sealant under the bottom wall plate between the plate and fibreboard spacer and between the gypsum board and the fibreboard spacer. Alternatively, apply a continuous bead of caulking at the subfloor/bottom plate corner prior to the installation of the fibreboard spacer and between the fibreboard and gypsum board.
- The fibreboard spacer provides a resilient support for the bottom edge of the gypsum board. Confirm acceptability with the authority having jurisdiction.
- Insulation installed in these assemblies provides important sound attenuation benefits. Fill the entire cavity.
- All electrical penetrations must be tightly fitted or sealed. Electrical boxes should be offset by at least 400 mm (16 in.) from boxes on the opposite side of the wall.
- Where possible, avoid installing plumbing in these walls.

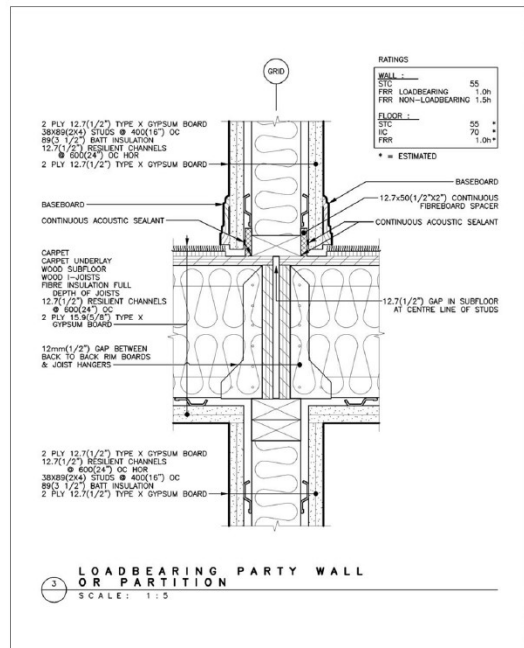

Detail 3: Loadbearing Party Wall or Partition

5-D Examples of Content

Sample figures for each section have been provided above.

Reference material

Canada Mortgage and Housing Corporation. *Fire and Sound Control in Wood-Frame Multi-Family Buildings*. Canada Mortgage and Housing Corporation: 2004

Canada Wood. *Fire Resistance and Sound Transmission in Wood-Frame Residential Buildings*. Canadian Wood Council: Ottawa, 2010

Canadian Wood Council. *Fire Safety and Security, A technical note on fire safety and security on construction sites in British Columbia*. Canadian Wood Council: Ottawa, 2015

Canadian Wood Council. *Fire Safety Design in Wood Buildings*. Canadian Wood Council: Ottawa, 1996

Canadian Wood Council. *Fire Safety in Residential Buildings*. Canadian Wood Council: Ottawa, 2000

Canadian Wood Council. *Introduction to Wood Building Technology*. Canadian Wood Council: Ottawa, 1997

Ministry of Natural Resources and Forestry, and Ministry of Municipal Affairs. *Ontario's Tall Wood Building Reference*. Ministry of Natural Resources and Forestry, and Ministry of Municipal Affairs: 2017

Outline Part 6: Project Planning & Construction

6-A Complexity, benefit, cost and time analysis

Complexity	High	Information is readily available for the construction-related topics. For the planning process topics, some information is available, but several sections will require new research, or updates.
Benefit	High	The industry and students would benefit from updated information on new technologies and how new technologies work with the construction process.
Cost	High	Research is required for several sections
Time required		

6-B Proposed Outline

	Content – Part 6	References	SC recommended
6.1	Planning	23	
	6.1.1. Planning and design 6.1.2. Stages of construction – house		
6.2	Costing - conceptual/design stage/procurement	45	Yes
	6.2.1. Cost comparison: wood, concrete and steel 6.2.2. Reducing costs in low rise residential		
6.3	Approvals, permits, codes and standards	23, 25, 31, 32, 28, 42	
	6.3.1 Codes and Standards		
6.4	Tendering	Research Required	
6.5	Builder's Risk Insurance	Research Required	
6.6	Procurement/Sourcing	50, Additional Research Required	
	6.6.1 Key considerations during conceptual design 6.6.2 Understanding local skills and trades 6.6.3 International supply		
6.7	Building Information Management		
	6.7.1 Case study	Research Required	Yes
6.8	Commissioning	Research Required	
	6.8.1 Pre-design phase 6.8.2 Design phase 6.8.3 Construction phase 6.8.4 Occupancy and operations phase 6.8.5 Retro-commissioning 6.8.6 Recommissioning		
6.9	Maintenance and repair		
	6.9.1 Maintenance checklist		
	6.9.1.1 Mass timber checklist		

	6.9.2 Repair and upgrading 6.9.2.1 Defective beams 6.9.2.2 Checked or delaminated glulam 6.9.2.3 Radial tension cracks in glulam 6.9.2.4 Decayed column bases 6.9.2.5 Decayed arch legs 6.9.2.6 Overstressed or defective heavy truss connections 6.9.2.7 Defective tension webs 6.9.2.8 Overstressed trusses		
6.10	Handling & Storage	36	Yes
	6.10.1. Light wood frame and mass timber differences 6.10.2. Moisture protection during construction 6.10.2.1. Drying of products once wet 6.10.2.2. European Union construction tent examples		
6.11	Fire protection during construction	42	
	6.11.1. Causes of construction site fires 6.11.2. Construction site fire safety plan 6.11.3. Considerations for mass timber buildings 6.11.4. Hot works permits (from site supervisor / project manager)		
6.12	Erection	Research required	Yes
	6.3.1 Light wood frame building erection sequences 6.3.2 Mid-rise wood building erection sequences 6.3.3 Tall wood, mass timber building erection sequences		
6.13	Inspection		
6.14	Prefabrication	50, 52, additional research required	Yes
	6.14.1 Role of timber in prefabrication 6.14.2 Shared components – BIM, CNC and mass customization 6.14.3 Whole building systems 6.14.4 Prefabrication approaches 6.14.5 Impact on construction time and cost 6.14.6 Prefabrication case study		
6.15	Workmanship	5	
	6.15.1 Defects in wood building products and materials 6.15.2 Structural defects in wood frame and post and beam construction 6.15.3 Other common defects		

6-C Content

6.1 Planning

This section will provide a high-level overview of the planning and design of a wood building, and the things that should be considered as the building progresses. The section will reference the CMHC's 'Canadian Wood Frame House Construction' chapter on Planning, Design, and Construction. The arrangement of topics is listed below. The sub-section on stages of construction for mid-rise and tall wood buildings will require further research

- 6.1.1. Planning and design
 - Site planning
 - Protection and care of materials on the building site
 - Excavation, footings and foundation
 - Framing (floor, wall, roof)
 - Exterior finishes
 - Flashing
 - Roof spaces and roofing
 - Fenestration
 - Stairs
 - Moisture, Air Leakage, Vapour Diffusion and Heat Transfer Control
 - Plumbing, Electrical, Heating and Ventilation
 - Interior Finishes
 - Decks, porches and balconies
 - Garages
- 6.1.2. Stages of construction – house

6.2 Costing

This section will provide a brief overview of how to estimate and cost a project. Because labour costing varies across the country, this section will focus more specifically on material costs. For mid- and high-rise buildings, a sub-section will reference the costing analysis provided by QS Online Cost Consultants for Atlantic WoodWorks. The analysis compares one building, but constructed with different combinations of structural materials (wood, concrete and steel). The cost analysis findings indicate that wood construction models are the least expensive to build.

For reducing costs in low rise residential buildings, another sub-section will provide a brief overview on improving affordability through optimal subdivision design and alternative development standards, conversion of underutilized buildings, and innovative house designs and construction practices.

- 6.2.1 Cost comparison: wood, concrete and steel for six storey wood building
- 6.2.2 Reducing costs in low rise residential

6.3 Approvals, permits, codes and standards

This section will an overview of the requirements for permits across Canada. These processes are in place to ensure that the property is zoned for the intended use before proceeding with house planning.

Best practice recommendations will be made, such as keeping drawings to scale and providing sufficient detail to enable a plans examiner to determine whether the proposed house is Code compliant. A figure will be provided to illustrate the general process (example provided below, from the CMHC's Canadian Wood Frame House Construction).

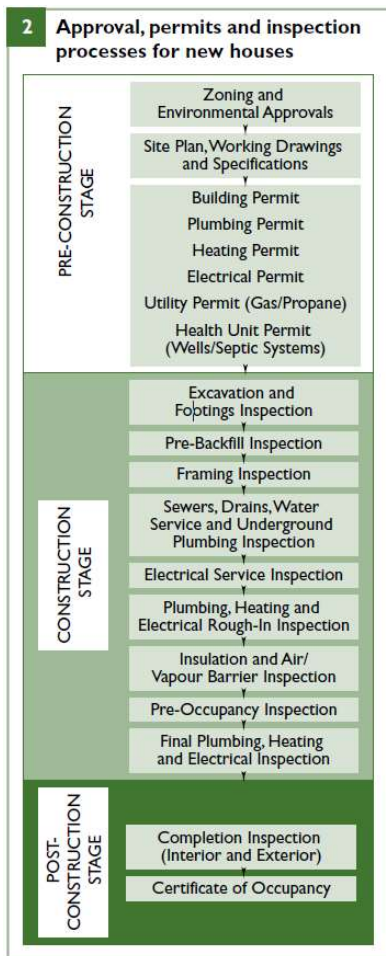

A sub-section will give an overview of the relevant Canadian building codes and standards that apply to wood frame buildings, and lumber products. Energy efficiency requirements for wood-frame buildings will be reviewed, including ASHRAE Standard 90.1, which is referenced by many North American building codes.

Background information will be provided on the recent building code changes, namely the provincial building code changes which allows mid- and high-rise wood frame and timber buildings: BC Building Code (BCBC), Quebec Building Code (QBC), Ontario Building Code (OBC), Alberta Building Code (ABC) and the National Building Code of Canada (NBC).

This section will also highlight the differences in mid- and high-rise building definitions across the provincial codes. For the purposes of this book, the NBC will be used to clarify the definitions of the different types of building.

- 6.3.1 Codes and Standards

6.4 Tendering

This section will briefly describe a typical tendering process. Additional research will be required to ensure the information is pertinent.

6.5 Builder's Risk Insurance

This section will contain general information on builder's risk insurance. This section will require new research and cooperation from insurance providers. This section will benefit from industry experience, shown through case studies.

6.6 Procurement/sourcing

This section will contain an overview of a typical procurement process, and provide some key considerations for component and material procurement or sourcing. This section will benefit greatly from case studies or anecdotes from the industry. The arrangement of topics listed below is based on Dan Tingley's 'Wood Construction Systems,' reference.

- 6.6.1 Key considerations during conceptual design
- 6.6.2 Understanding local skills and trades
- 6.6.3 International supply

6.7 Building Information Modelling

This section will require new research. This section will introduce Building Information Modelling (BIM). The opportunities for BIM in mass timber buildings will be presented, in addition to a case study of a building that utilized BIM software.

- 6.7.1 Case study

6.8 Commissioning

This section will introduce the building commissioning process, and the typical steps involved. This section may require additional research to ensure that information is up to date. The arrangement topics are listed below.

- 6.8.1 Pre-design phase
- 6.8.2 Design phase
- 6.8.3 Construction phase
- 6.8.4 Occupancy and operations phase
- 6.8.5 Retro-commissioning
- 6.8.6 Recommissioning

6.9 Maintenance and repair

This section will contain best practice recommendations to maintain the good condition of wood buildings. This section may require additional research, particularly as pertains to mid-rise and tall wood buildings. The topics for repairing and upgrading wood buildings included below are based on the CWC's 'Introduction to Wood Building Technology,' reference.

- 6.9.1 Maintenance checklist
 - 6.9.1.1 Mass timber checklist
- 6.9.2 Repair and upgrading
 - 6.9.2.1 Defective beams
 - 6.9.2.2 Checked or delaminated glulam
 - 6.9.2.3 Radial tension cracks in glulam
 - 6.9.2.4 Decayed column bases

- 6.9.2.5 Decayed arch legs
- 6.9.2.6 Overstressed or defective heavy truss connections
- 6.9.2.7 Defective tension webs
- 6.9.2.8 Overstressed trusses

6.10 Storage and Handling

This section describes how to properly store, handle and transport wood building products to ensure good long term performance. This section will also describe the defects that could occur if wood building products are handled improperly (decay, sapstain, weathering, and shrinkage defects).

This section will also contain a sub-section of recommendations for proper storage and handling which are specific to certain wood building products will be described, where applicable. For example, storage and handling instructions from the APA's Engineered Wood Construction Guide will be used for engineered wood products.

A sub-section for moisture protection during construction will be included. This sub-section will address how wood products dry after becoming wet. As well, examples of construction tents used in the European Union will be provided. Additional research may be required on this specific example.

This section will be arranged according to the topic list below.

- 6.10.1. Light wood frame and mass timber differences
- 6.10.2. Moisture protection during construction
 - 6.10.2.1. Drying of products once wet
 - 6.10.2.2. European Union construction tent examples

6.11 Fire protection during construction

This section will describe general construction site safety to reduce the risk of fires during the construction stage. This section references the 'Ontario Tall Wood Building Reference.' The section will include the following topics:

- 6.11.1. Causes of construction site fires
- 6.11.2. Construction site fire safety plan
- 6.11.3. Considerations for mass timber buildings
- 6.11.4. Hot works permits (from site supervisor / project manager)

6.12 Erection

This section will provide a summary of the erection sequences for wood buildings. This section will require additional research, especially for mid-rise and tall wood buildings. Photographs and illustrations will need to be produced to provide adequate illustrations. This section will include the following topics:

- 6.12.1 Light wood frame building erection sequences
- 6.12.2 Mid-rise wood building erection sequences
- 6.12.3 Tall wood, mass timber building erection sequences
 - Similarities with steel construction

6.13 Inspection

This section presents best practices to ensure the good condition of wood buildings. This section will follow the content layout as provided in the CWC's 'Introduction to Wood Building Technology' reference. Additional research may be required to maintain update information, addition of photographs, and for the creation of a 'checklist' for inspections, similar to the one provided in the figure below, from the CMHC's 'Wood-Frame Envelopes Best Practice Guide Building Technology.'

The arrangement of topics in this section is listed below:

- 6.13.1 Inspection
 - Exterior inspection
 - General inspection of framing and members
 - Detailed inspection
 - Decayed members
 - Carpenter ant damage
 - Termite damage
 - Fire damage
 - Checks and splits sawn timber
 - Inspection of glulam (checking, delamination, radial tension failures)
 - Alignment of trusses and arches
 - Mechanical damage to columns
 - Sagging or broken beams
 - Excessive notches in beams and purlins
 - Shear failures at heel connections
 - Broken truss members
 - Connection failures (splits, gaps, missing fasteners or incorrect installation)
 - Inspection checklist

Sample checklist from CMHC's 'Wood-Frame Envelopes Best Practice Guide Building Technology.'

Table 10.2: Building Inspection Checklist

	NORTH	SOUTH	EAST	WEST
Brick Veneer				
Cracked Unit				
Efflorescence				
Missing/Clogged Weepholes				
Deteriorated Mortar Joints				
Cracked Mortar Joints				
Spalled Units				
Stains				
Water Penetration				
Flashing				
Bent				
Missing				
Sealants				
Splits				
Peeling				
Missing or Incomplete Sections				
Surface Bubbling				
Siding				
Split				
Deformed/Warped				
Loose				
Finish Deteriorated				
Stucco				
Cracked				
Chipped				
Paint				
Peeling				
Blistering				
Roof Shingles				
Missing/Broken				
Cupped/Deteriorated				
Fascias and Soffits				
Bent or Displaced				
Finish Deteriorated				

6.14 Prefabrication

This section will include information on the construction process options that are available for wood buildings. The topics listed below are based on the references titled ‘Wood Construction Systems,’ and ARUP’s ‘Rethinking Timber Buildings’ publication. Additional research will be required to ensure the information presented is relevant to a Canadian audience. Case studies would also strengthen this section. The section will include the following topics listed below, with sample figures provided.

- 6.14.1 Role of timber in prefabrication
- 6.14.2 Shared components – BIM, CNC and mass customization
- 6.14.3 Whole building systems
- 6.14.4 Prefabrication approaches
- 6.14.5 Impact on construction time and cost
- 6.14.6 Prefabrication case study

Sample figure on the presentation of prefabrication approaches, from the ‘Wood Construction Systems,’ published by Forest and Wood Products Australia.

5.2.2 Panels

Icon	 Diagram 
Description	Prefabricated panels include preassembled wall frames, nailplate and other floor and roof trusses, floor cassettes, stressed skin panels, assembled post and beam units, and massive timber panels. In their simplest form, they are open frame items that are installed and fixed to other panel elements to make a structural frame. As the level of preplanning increases, wall assemblies can include factory-fitted doors and windows and lining on one side or be fully insulated, serviced and lined both sides before being lifted into place. Floor cassettes can be assembled from individual floor trusses or joists and interconnected with edge beams, braces and flooring. Massive timber components are generally made for the required span and delivered to site as panels cut to size for location. While transport regulations enforce some size limits, large timber panels can usually be transported economically and installed with standard lifting equipment.
Applications	Panels can be used in timber-rich buildings of any size. Prefabricated wall frames and nailplate trusses are very common in low to mid-rise residential and commercial buildings. Floor cassettes and clad wall frames are well suited for similar sizes and classes of buildings. Massive timber panel systems are being used in buildings to ten storeys and beyond.



Figure 10: Prefabricated wall frames and floor cassette

6.15 Workmanship

In many provinces, workmanship is regulated by the local home warranty corporation. Good workmanship generally attempts to avoid building defects in relation to the requirements of local building codes, and in some provinces the requirements of the construction performance guideline promoted by the warranty corporation. This section delivers in detail approaches for builders to deliver good workmanship in their projects.

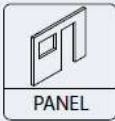
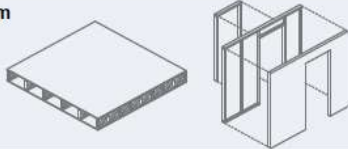
This section will contain a summary of the expected level of workmanship on the construction site. This section will likely be one of the most important sections for the builder audience, as workmanship directly affects the potential for defects in the finished product. Ensuring good workmanship will be vital to reducing the likelihood of defects and warranty claims. The checklists for new construction from the 'Introduction to Wood Building Technology,' are included in this section. The checklists are intended to verify that the best practices presented up until now have been followed.

- 6.15.1 Defects in wood building products and materials
- 6.15.2 Structural defects in wood frame and post and beam construction
- 6.15.3 Other common defects:
 - Defects in thermal insulation, air, vapour, and weather barriers
 - Fire protection and sound control defects

- Building services
- Interior and exterior finish defects

Figure 11.1
Correction for
inadequate
beam bearing

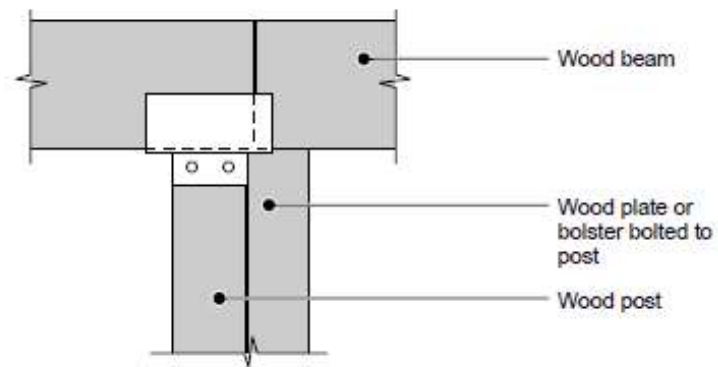
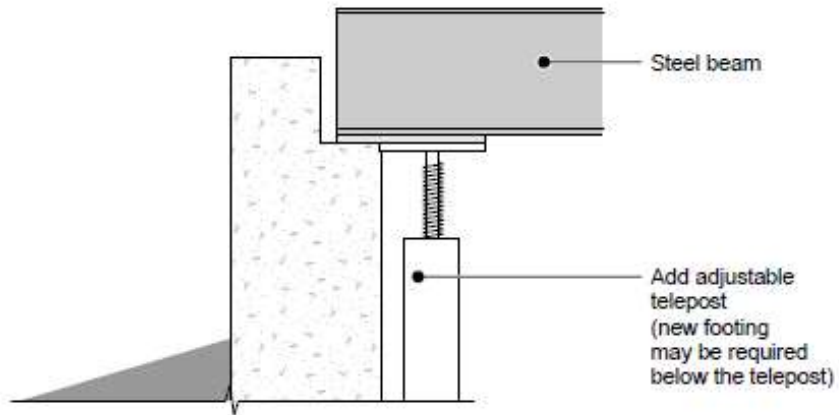
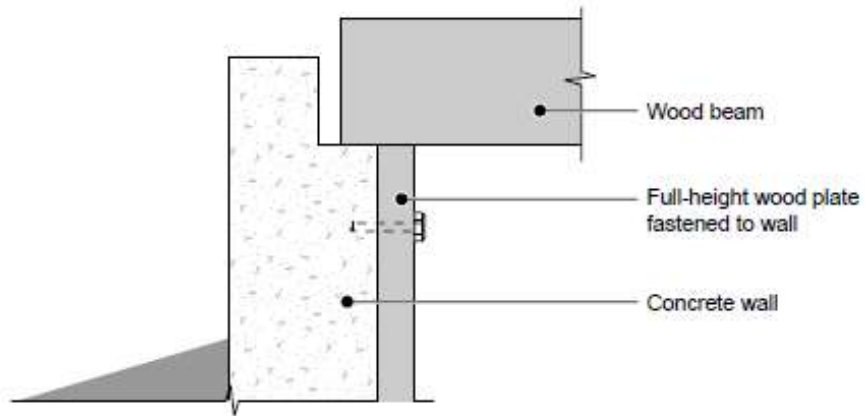

6-D Examples of Content

Sample figures for each section have been provided above.

Reference material

APA – The Engineered Wood Association. *Engineered Wood Construction Guide*. APA – The Engineered Wood Association, 2016

ARUP. *Rethinking Timber Buildings*. ARUP: London, 2019

Burrows, John. *Canadian Wood-frame House Construction*. Canada Mortgage and Housing Corporation: Canada, 2013

Canada Mortgage and Housing Corporation. *Wood-Frame Envelopes: Best Practice Guide Building Technology*. Canada Mortgage and Housing Corporation, 2004

Canadian Wood Council. *Introduction to Wood Building Technology*. Canadian Wood Council: Ottawa, 1997

Centre d'expertise sur la construction commerciale en bois. *Guide technique sur la conception de bâtiments de 5 ou 6 étages à ossature légère en bois*. Centre d'expertise sur la construction commerciale en bois, 2016

Ministry of Natural Resources and Forestry, and Ministry of Municipal Affairs. *Ontario's Tall Wood Building Reference*. Ministry of Natural Resources and Forestry, and Ministry of Municipal Affairs: 2017

Morrison Hershfield. *Reference Guide: Mid-rise Wood Construction in the Ontario Building Code*. WoodWorks: Ottawa, 2015

Ni, Chun, and Marjan Popovski. *Mid-Rise Wood Frame Construction Handbook*. FP Innovations: 2017

QS Online Cost Consultants. *Six Storey Model Comparison*. Atlantic Woodworks: Amherst, 2017

Tingley, Dan. *Wood Construction Systems*. Forest and Wood Products Australia, 2018

Teacher's Compendium

7-A Complexity, benefit, cost and time analysis

Complexity	Moderate	Information is available. Work is required to translate the information into student course material
Benefit	High	Students will benefit greatly
Cost	Moderate	
Time required	32 hours	The majority of the work will be creating the questions and exercises.

7-B Proposed Outline

	Content – Part 10 Teacher's compendium	References	SC recommended
10.1	Introduction	53	
10.2	Suggested Lecture Schedule		
10.3	Part 1 Introduction		
10.4	Part 2 Wood Building Products		
10.5	Part 3 Structural Systems		
10.6	Part 4 Building Envelope		
10.7	Part 5 Fire		
10.8	Part 6 Sound		
10.9	Part 7 Construction		
10.10	Part 8 Process		

7-C Content

This section is based on the Instructor's Manual for the textbook, 'Fundamentals of Building Construction,' by Edward Allen and Joseph Iano. This section will contain materials for the post-secondary instructor, and includes suggested lecture schedules, section objectives, sample test, and assignments. The topics covered are listed below:

- 10.1 Introduction
- 10.2 Suggested Lecture Schedule
- 10.3 Part 1 Introduction
- 10.4 Part 2 Wood Building Products
- 10.5 Part 3 Structural Systems
- 10.6 Part 4 Building Envelope
- 10.7 Part 5 Fire
- 10.8 Part 6 Sound
- 10.9 Part 7 Construction
- 10.10 Part 8 Process

Sections 10.3 to 10.13 will include the include the following sub sections:

- A. Learning objectives
- B. Review questions and answers (short answer)
- C. Additional questions (short answer)
- D. True and False questions
- E. Multiple Choice questions
- F. Class exercises
- G. Additional activities
 - Suggestions for guest speakers
- H. Additional resources

7-D Examples of Content

6. Redwood, Cypress, and various Cedars are the resistant species most common in North America.

7. Nails are inexpensive and versatile, they usually do not require advance drilling of holes, and they are quickly driven by hammer or nailgun.

B. Additional Questions

1. List ___ species of wood commonly used for _____. (This question has many variations, one of which is to ask the student to specify a set of wood species for a particular project, including framing, outdoor decks, flooring, stair treads, and interior millwork. The answers are found in Figure 3.5 of the text.)

2. What are the advantages of quartersawn lumber? For what kinds of end uses would you specify it? (Answer: Quartersawn lumber is less prone to seasoning distortions, has a tighter grain figure, and has improved surface wearing qualities over plainsawed lumber. It is especially useful for flooring, interior trim pieces, architectural millwork, and furniture stock.)

3. What grade of plywood veneer would you specify for a surface to be painted? For the backside of a sheathing panel? (Answers: A, D)

4. A variety of questions can be posed that require knowledge of lumber dimensioning to solve. For example, you might show a detail of a foundation wall with a nominal 2" sill, 2 by 12 floor joists, and 5/8" plywood subflooring, and ask the student to figure the total actual distance from the top of the foundation to the top of the subfloor.

5. What will be the cost of 27 2 by 8s, each 14' long, if the price of the lumber is \$600.00 per thousand board feet? (Answer: \$302.40)

6. What is a satisfactory method of joining joists that meet at right angles? (Answer: Joist hanger for loadbearing connections; end nailing may be acceptable for nonloadbearing connections.)

C. True-False Questions

1. The heartwood of a living tree is dead wood. (T)

2. Summerwood is stronger and stiffer than springwood. (T)

3. Wood treated with pentachlorophenol can be painted. (F)

4. Box nails and common nails are interchangeable in construction practice. (F)

5. Sheet metal joist hangers are used to make a strong connection wherever wood joists bear on one another at right angles. (T)

6. Wood is the only primary structural material that is a renewable resource. (T)

D. Multiple Choice Questions

1. Which type of wood shrinkage is greatest?
 - a. Longitudinal
 - b. Radial
 - c. Tangential(Answer: c)

2. Which of the following are growth characteristics:
 - a. Twisting
 - b. Knot
 - c. Check
 - d. Decay
 - e. Wane
 - f. Cupping(Answer: b, d)

3. Lag screws are inserted with:
 - a. A hammer
 - b. A screwdriver
 - c. A wrench
 - d. A pneumatic gun(Answer: c)

4. Adhesives are widely used on the construction job site for:
 - a. Laminating beams
 - b. Connecting framing members
 - c. Bonding the frame to the foundation
 - d. Attaching subflooring and wall panels to framing members(Answer: d)

E. Using the Exercise Book

To the beginning student, the topic of wood is a bewildering forest of species, grades, sawing patterns, nominal and actual sizes, board foot measurement, and fasteners. The two exercises for this chapter help the student to become more comfortable and confident in finding her or his way through this forest, simply by stepping them through the information and asking them to work creatively with it. This knowledge is indispensable to any architect or construction professional who works with wood light frame construction. A good way to motivate your students to do these exercises well is to point out the likelihood that some of them will be designing their own residential projects within the next several years, and that they will have to feel at home with this information to do so successfully. You can vary these exercises from one year to the next by substituting different lumber sizes, prices, and other particulars.

Each exercise can be completed within a half-hour to an hour, depending on the student's familiarity with the topic.

F. Additional Activities

1. Field trips to lumber or plywood mills are well worth the time they take, if there are such facilities in your area. Wood truss fabrication is fascinating in its repetitive efficiency, making a visit to a truss factory an eye-opener. Even a tour of a retail lumberyard with a knowledgeable guide can be useful.

2. It is rather easy to put together a display for your students of sample blocks of different species of wood; different sizes and types of nails, screws, and bolts; joist hangers and other sheet metal connecting devices; plywood and panel samples; engineered lumber samples, and trade literature on laminated wood, plywood, and wood panel products. Encourage the students to compare color, density, odor, and grain figure of the wood samples. Demonstrate how a ten penny nail is just the right length to face-nail two 2-inch members together, and how 8d nails work well for fastening plywood to framing. Show how a 16d nail is the right length to end-nail a stud to a plate, while a 10d or 12d is too short. Drive some deformed-shank nails into a block of wood and let students try to remove them with a claw hammer.

G. Additional Resources

1. The American Wood Council, 1111 Nineteenth Street, NW, Suite 800, Washington, DC 20046, (202) 463-2766, www.awc.org, develops and publishes definitive standards for wood design and construction. The AWC web site is an excellent source for links to technical resources and additional industry associations. The site also includes a collection of freely downloadable course presentations on topics including wood standards, engineering, and construction at <http://www.awc.org/HelpOutreach/eCourses/>.

2. Some additional websites to explore:

www.certifiedwood.org	Forest Certification Resource Center
www.wvpa.org	Western Wood Products Association
www.woodtruss.com/index.php	Wood Truss Council of America
www.southernpine.com	Southern Pine Council
www.apawood.org	APA – The Engineered Wood Association
www.paslode.com	Paslode nailguns
www.strongtie.com	Simpson Strong-Tie Fasteners

H. Attention Getters

1. Bring samples of woods and fasteners to class. Say a bit about each and pass them around. This is most effective if you do only a few wood species that are clearly different from one another, such as Oak, Redwood, Incense cedar, Maple, Walnut, Mahogany, Sugar pine, and Douglas fir. The differences among wood screws, drywall screws, lag screws, and bolts can be made readily apparent in this situation, as well as the differences between common bright, common galvanized, finish, and ring-shank nails.

Reference material

Allen, Edward, and Iano, Joseph. *Fundamentals of Building Construction: Materials and Methods*. John Wiley and Sons: Hoboken, New Jersey, 2004

APPENDIX B – CWC WOOD HANDBOOK FOR BUILDERS STEERING COMMITTEE MEMBERS

	Name	Organization
1	Alex Potyondy	Nova Scotia Community College
2	Alison Conroy	Pelican Consulting
3	Anthony Boyko	City of Markham
4	Brent Bunting	Simpson Strong Tie
5	Brent Olund	Urban One Builders
6	Bryan Schilling	RNDesign
7	Caleb Howden	Denim Homes Inc.
8	Carlo F. Velcic	Southern Alberta Institute of Technology (SAIT)
9	Cory McCambridge	APA – The Engineered Wood Association
10	David Moses	Moses Structural Engineers
11	Errol Fisher	CHBA/North Ridge Development Corp
12	Farhoud Delijani	University of Manitoba
13	Guido Wimmers	Pelican Consulting
14	Jeff Armstrong	Cold Climate Building
15	Jennifer Weatherston	Timber Worx
16	Kenneth Williams	Northern Alberta Institute of Technology (NAIT)
17	Marianne Brown	Orr Brown consulting
18	Michael Janotta	Town of Richmond Hill
19	Paul DeBerardis	RESCON
20	Rick Ward	Mitek
21	Robert Kok	H+me Technology
22	Steven Street	Wood WORKS
23	Vera Straka	Ryerson University
24	Y.H. Chui	University of Alberta