



Canadian  
Wood  
Council

Conseil  
canadien  
du bois



# Moisture and Wood-Frame Buildings

**Building Performance Series No. 1**

# Building Performance Bulletin

For more information and links to helpful and related information sources, visit the Wood Durability web site at [www.durable-wood.com](http://www.durable-wood.com). A downloadable PDF version of this publication is also available from the site.



© 2000 Copyright  
Canadian Wood Council  
Ottawa, Ontario, Canada  
40M1200

Compiled by:  
Michael Steffen, Walsh Construction Company

Design and production by:  
Accurate Design & Communication Inc.

Printed by:  
Lomor Printers Ltd.

## Introduction

**T**hroughout history, wherever wood has been available as a resource, it has found favor as a building material for its strength, economy, workability and beauty, and its ability to last has been demonstrated again and again. From the ancient temples of Japan and the great stave churches of Norway to the countless North American buildings built in the 1800s, wood construction has proven it can stand the test of time. The art and technology of wood building, however, has been changing through time. Can modern wood-frame buildings perform as well?

Protection of buildings from moisture is an important design criterion, as important as protection from fire or structural collapse. Designers, builders and owners are gaining a deeper appreciation for the function of the building envelope (exterior walls and roof). This includes the performance of windows, doors, siding, sheathing membranes, air and vapour barriers, sheathing, and framing. The capabilities and characteristics of wood and other construction materials must be understood, and then articulated in the design of buildings, if proper and durable construction is to be assured.

This guide will help design and construction professionals, and building owners understand moisture issues related to the design and construction of wood-frame buildings.

The primary objective is to provide ideas and solutions to ensure wood-frame buildings perform as expected. The primary focus of the guide will be on the control of rainwater penetration in exterior walls, particularly for climates subject to high moisture exposure.



**PHOTO 1:** Stave Church at Urnes, Norway – Norway’s oldest stave church that dates back to the early 12<sup>th</sup> century in its present form. Wooden components of an even older church were used to build it.

## LANESBOROUGH – GOING THE EXTRA MILE

Designed and built expressly for the wet West Coast climate of Vancouver, Canada, the Lanesborough condominiums goes the extra mile by applying state-of-the-art design and construction incorporating advanced moisture protection systems. Key features include what the developer describes as ‘umbrella architecture’ that emphasizes large overhangs and sloping roofs, combined with a multi-layer rainscreen wall system. On-site testing, quality inspection during construction and working with a team of engineers and building envelope experts were also integral parts of this state-of-the-art building approach.

Key construction details:

- Through wall flashing to direct water away from the building envelope
- Durable bevel cedar siding and fire retardant treated No.1 red cedar roof shingles
- Pressure treated 3/4” x 2” wood strapping on the walls, creating a 3/4” airspace and drainage plane
- 3/8” softwood plywood on the walls, with top

and bottom venting of each stud cavity

- Kiln dried framing materials including 2 x 4” finger-joined studs for exterior walls and party walls, and S-P-F floor joist
- New generation engineered wood products, including laminated veneer lumber, parallel strand lumber and wood roof trusses



**PHOTO 2:** Lanesborough Condominiums

## Moisture and Wood

Wood and water are typically very compatible. Wood is a hygroscopic material, which means it has the ability to release or absorb moisture to reach a moisture content that is at equilibrium with its surrounding environment. As part of this natural process, wood can safely absorb large quantities of water before reaching a moisture content level which is favourable to the growth of decay fungi. To ensure durable wood-frame buildings, the design of the structure and envelope should be based on an understanding of factors that influence the moisture content of wood and changes that occur due to variations in moisture content.

Understanding the moisture content of wood is crucial, as 1) varying moisture content leads to shrinking and swelling of wood members, and 2) high moisture content can lead to the growth of mould and decay fungi. *Moisture content (MC)* is a measure of how much water is in a piece of wood relative to the wood itself. MC is expressed as a percentage and calculated by dividing the weight of water in the wood by the weight of that wood if it were oven dry. Two important MC numbers to remember are:

1. **19%:** We tend to call a piece of wood “dry” if it has an MC of 19% or less. This type of lumber is grade marked as S-DRY for surfaced dry, or dry at time of manufacture. (Note: Some lumber is also marked KD for kiln-dried, and this also means dry at time of manufacture).
2. **28%:** This is the average fibre saturation point for wood where all the wood fibres are fully saturated. At moisture contents above the fibre saturation point, water begins to fill the cell. Decay can generally only get started if the moisture content of the wood is above fibre saturation for a prolonged period of time. The fibre saturation point is also the limit for wood swelling.

Wood shrinks or swells as its moisture content changes, but only when water is taken up or given off from the cell walls. This only occurs when wood changes moisture content below the fibre saturation point. Wood used indoors will eventually stabilize at 8-14% moisture content; outdoors at 12-18%.

## Shrinkage and Swelling

Wood shrinks or swells when it loses or gains moisture below its fibre saturation point. The amount of dimensional change is estimated at 1% of the width or thickness of lumber for every 5% change in moisture content.

Shrinkage is to be expected in lumber across its width while longitudinal shrinkage is likely to be negligible, such as the vertical shrinkage of a wall stud. In a wood-frame structure, shrinkage occurs primarily in horizontal members such as wall plates and floor joists. In buildings designed to three, four or five stories, the effects of cumulative shrinkage can affect the building envelope, such as the exterior cladding. Special consideration must be given to designs that allow for shrinkage. (Visit [www.cwc.ca](http://www.cwc.ca) and try *deltaCALC*, a software tool for determining the amount of shrinkage and swelling in wood.) For example, when a wood-frame structure is combined with a brick veneer, a concrete block elevator shaft or stair tower, or a steel-frame building element, the cumulative effects of differential movement in a multi-story building must be accounted for in the detailing and specifications.

**FIGURE 1:** In taller wood-frame buildings, design of the joints between building envelope components must allow for differential shrinkage. At this window on the third floor of a wood-frame building, a 1" wide sealant joint has been installed between the window frame and the masonry sill. As the wood framing shrinks, the joint allows the window to move downward with the framing to which it is attached. If the joint was only 1/2" wide it is possible the window frame would bind and rack on the top edge of the concrete sill.

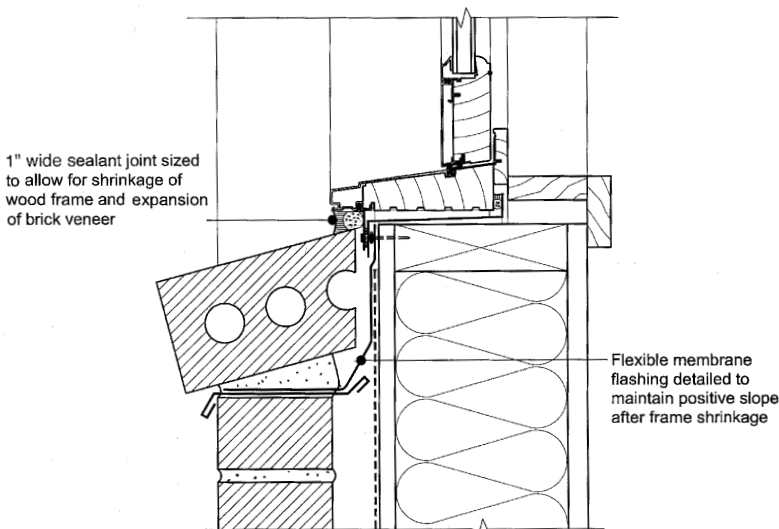

Specification of dry lumber is an important step towards minimizing shrinkage. One advantage of using dry lumber is that most of the shrinkage has been achieved prior to purchase (wood does most of its shrinking as it drops from 28 to 19%). It will also lead to a more predictable in-service performance as the product will stay more or less at the same dimension it was upon installation.

Another way to avoid shrinkage and warp is to use composite wood products such as plywood, OSB, finger-jointed studs, I-joists and structural composite lumber. These products are assembled from smaller pieces of wood glued together. Composite products have a mix of log orientations within a single piece, so one part constrains the movement of another. For example, plywood achieves this crossbanding form of self-constraint. In other products, movements are limited to very small areas and tend to average out in the whole piece, as with finger-jointed studs.

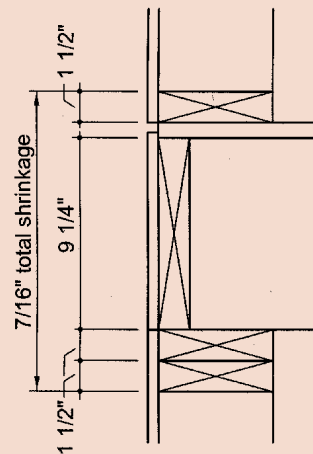

Shrinkage at Platform Framing

**FIGURE 2:** Details have been developed to minimize the effects of cumulative shrinkage. One such detail reduces the impact of cross-grain shrinkage of joists by not setting the wall frame on top of the joists below, as is common in platform framing. Instead, the walls are framed up to the level of the floor above and the floor joists are hung from that framing with steel hangers.

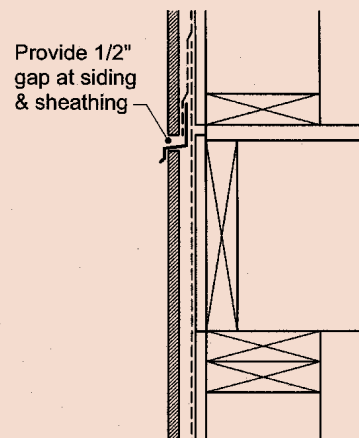

Accommodating Shrinkage

## Decay

The primary durability hazard with wood is *biodeterioration*. Wood in buildings is a potential food source for a variety of fungi, insects and marine borers. These wood-destroying organisms have the ability to break down the complex polymers that make up the wood structure. The wood-inhabiting fungi can be separated into moulds, stainers, soft-rot fungi and wood decay fungi. The moulds and stainers discolour wood, however, they do not damage the wood structurally. Soft-rot fungi and wood decay fungi can cause strength loss in wood, with the decay fungi responsible for deterioration problems in buildings.

Decay is the result of a series of events including a sequence of fungal colonization. The spores of these fungi are ubiquitous in the air for much of the year, but only lead to problems under certain conditions. Wood decay fungi require wood as their food source, an equable temperature, oxygen and water. Water is normally the only one of these factors we can easily manage. Wood decay fungi also have to compete with other organisms, such as moulds and stainers, to get a foothold in wood materials. It is easier to control decay fungi before decay has started since these pre-conditions can inhibit growth rates at the start.

Decay and mould are terms that are often used interchangeably in the context of moisture-related wood damage. It is important to understand the distinction. Mould fungi can grow on wood (and many other materials), but they do not eat the structural components of the wood. Therefore, mould does not significantly damage the wood, and thus mould fungi are not wood-decay fungi. However, some types of moulds have been associated with human health problems, so the growth of mould in sufficient quantity and exposure to occupants is of potential concern regardless of physical damage to building products. Unfortunately, the relationship between mould and health is not yet fully understood. We live safely with some moulds in the air all the time, so clearly there are issues of thresholds, individual sensitivities, and other variables that still need to be determined by health experts and building scientists.

Decay fungi, a higher order of fungi than moulds, break down basic structural materials of wood and cause strength loss. Decay fungi are not associated with any human health problems.

Mould and decay do not necessarily occur together, nor are they indicators of each other. There tends to be a gradual transition from moulds to decay fungi if moisture conditions continue to be wet.

## Moisture Load

Design for durability begins with an understanding of moisture loading and how this interacts with building materials. Where does water come from? How is it transported? How can it be controlled? How can it be removed?

Moisture flows within any building must be managed to prevent water accumulation or storage that may lead to premature deterioration of building products. Water will lead to deterioration by corrosion in steel products, by spalling and cracking in concrete products, and by fungi in wood products.

## Moisture Balance

There are two general strategies to moisture control in the building envelope:

- limit the moisture load on the building
- design and construct the building to maximize its tolerance to moisture, to a level appropriate for the moisture load

The key design objective is to keep building envelopes dry, and to achieve moisture balance, where wetting and drying mechanisms are balanced to maintain moisture content levels at or below the tolerance level.

The concept of “load” is well established in structural design, where dead loads, live loads, wind loads, seismic loads and thermal loads are fundamental to the design process. Similarly, moisture loads are placed on a building and these loads must be accounted for and balanced in the building envelope design. The nature and magnitude of the loads will vary greatly depending upon the climatic situation, as well as occupancy of the building. The following section describes the most common moisture sources that create these moisture loads on buildings.

## Moisture Sources

Moisture sources in and around buildings are abundant. Interior moisture sources include building occupants and their activities. Some studies have concluded that a family of four can generate 10 gallons of water vapour per day.

Exterior moisture sources include precipitation, irrigation systems and groundwater. Water vapour is also present in the exterior environment and may significantly affect the building envelope in some climates.

An additional source of moisture is often called construction moisture. This is water contained in concrete, grout, wood and other building materials during the time of construction. This amount of moisture can be substantial and allowance must be made for drying before or after the building envelope is enclosed.

Rainwater, especially wind driven, is the moisture source that impacts the performance of the envelope most, and is the focus of this guide.

## Moisture Transport Mechanisms

The migration of moisture into and through building assemblies generally takes place by any of four moisture transport mechanisms: liquid flow, capillarity, convection or diffusion. Liquid flow and capillarity into the building envelope occur primarily with exterior source moisture such as rainwater and groundwater, whereas movement of moisture into the building envelope by diffusion or air movement can occur with interior or exterior source moisture.

*Liquid flow* is the movement of water under the influence of a driving force (such as gravity, or suction caused by air pressure differences).

*Capillarity* is the movement of liquid water in porous materials resulting from surface tension forces. Capillarity, or capillary suction, can also occur in the small space created between two materials.

*Air movement* refers to the movement of water vapour resulting from air flow through spaces and materials.

*Diffusion* is the movement of water vapour resulting from a vapour pressure difference.

Of the four transport mechanisms, liquid flow and capillarity are the most significant. Thus, it is not surprising that rain penetration and groundwater control has been the primary focus of builders and designers for generations. Air movement and vapour diffusion are important, though less significant and obvious contributors to moisture problems.

## Exposure

The design of building envelope assemblies must be based on an evaluation of the probable exposure to moisture. For exterior walls, design exposure, moisture load, is primarily a function of three conditions:

- Macro-climate: regional climatic norms
- Micro-climate: site-specific factors such as siting, solar exposure, wind exposure, and relationship to surrounding buildings, vegetation and terrain
- Building design: protective features such as overhangs & cornices

The levels of exposure can vary significantly on a single building, and the design of exterior wall assemblies can reflect these differences. There is significant research underway to characterize the degree of exposure in different climates.

As an example of climate classification, building scientist Joseph Lstiburek has developed the concept of *limit states* as applied to building durability. Furthering the notion that concepts of load and load resistance are as applicable to moisture design as they are to structural design, Lstiburek writes: “We should consider rain, temperature, humidity and the interior climate as environmental loads, and limit states as decay, mould and corrosion.”

Lstiburek proposes that building envelopes and mechanical systems should be designed relative to a set of *hazard classes* that, taken together, define the environmental load:

- Hygro-Thermal Regions
  - Severe-Cold
  - Cold
  - Mixed-Humid
  - Hot-Humid
  - Hot-Dry/Mixed-Dry
- Rain Exposure Zones
  - Extreme: over 60 inches annual precipitation
  - High: 40 to 60 inches annual precipitation
  - Moderate: 20 to 40 inches annual precipitation
  - Low: under 20 inches annual precipitation
- Interior Climate Classes
  - Uncontrolled (warehouses, garages, storage rooms)
  - Moderated (houses, apartments, offices, schools, commercial and retail spaces)
  - Controlled (hospitals, museums, swimming pool enclosures and computer facilities)

**FIGURE 3:** Hygro-Thermal Regions of North America

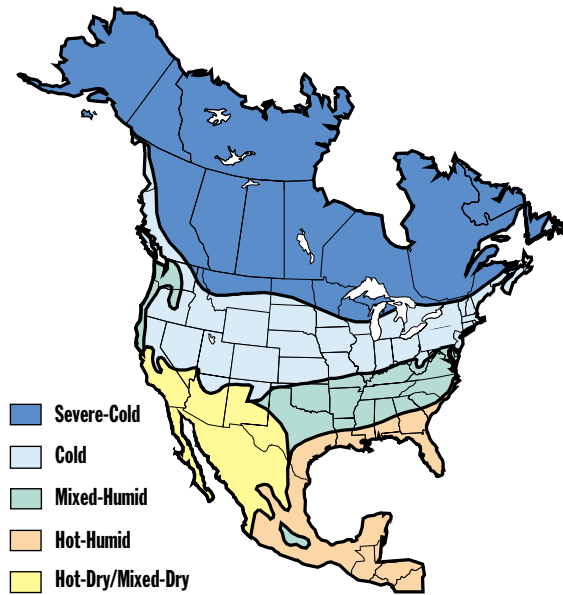

**FIGURE 4:** Rain Exposure Zones of North America

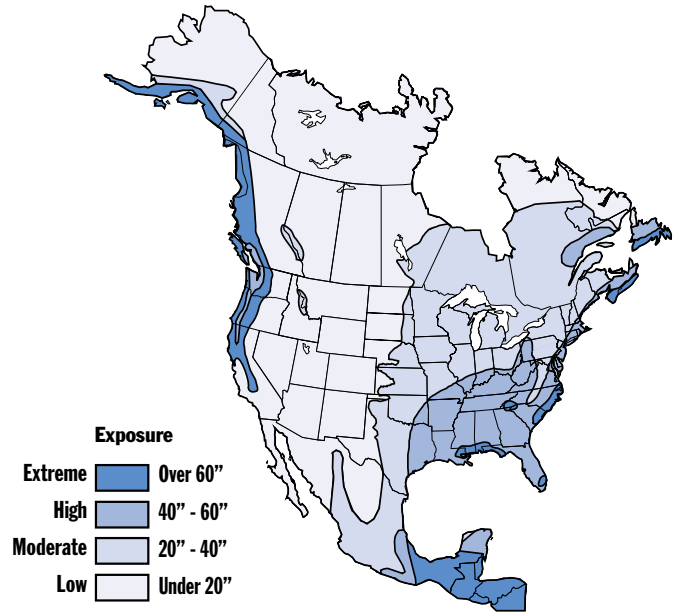

The approach above for defining rain exposure zones based on the amount of rainfall by itself could be improved by considering wind effects, as these often increase the moisture load.

An analysis of these hazard classes and the varying environmental loads they place on the building pro-

vides the designer with base criteria for wall type selection. The actual exposure level, however, can be influenced by micro-climate and building design factors, and these must be accounted for in a prudent selection process (see Table 1). The Canada Mortgage and Housing Corporation has published a nomograph (applicable to Vancouver, Canada) to analyze exposures based on micro-climates and design factors. The principle criteria are overhang ratio and terrain (the primary influence on the micro-climate of a given site). Analysis with a tool such as the nomograph allows the designer to further refine the criteria for wall type selection.

$$\text{Overhang Ratio} = \frac{\text{Overhang Width}}{\text{Wall Height}}$$

where,

Overhang width = horizontal distance between the outer surface of the cladding and the outer surface of the overhang

Wall height = height above the lowest affected wood element (therefore do not include concrete foundation walls)

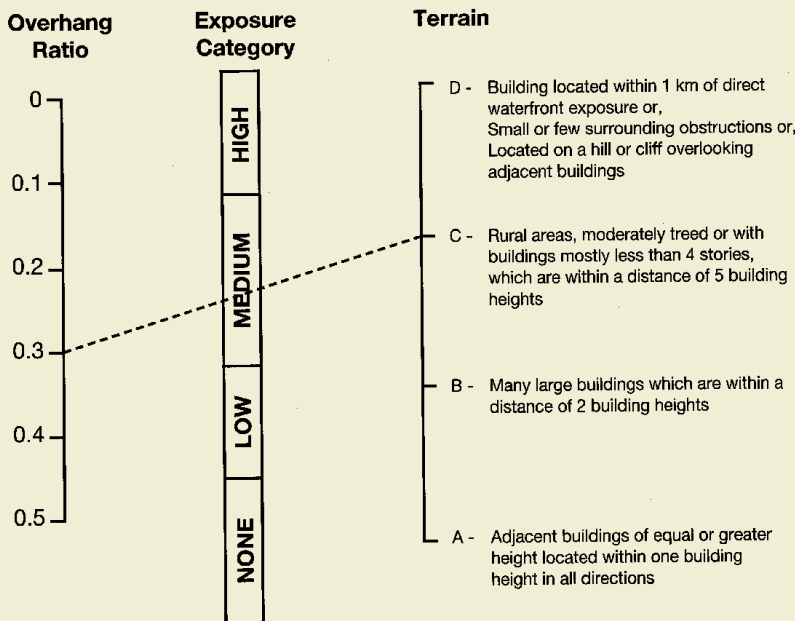

**FIGURE 5:** Exposure Category Nomograph

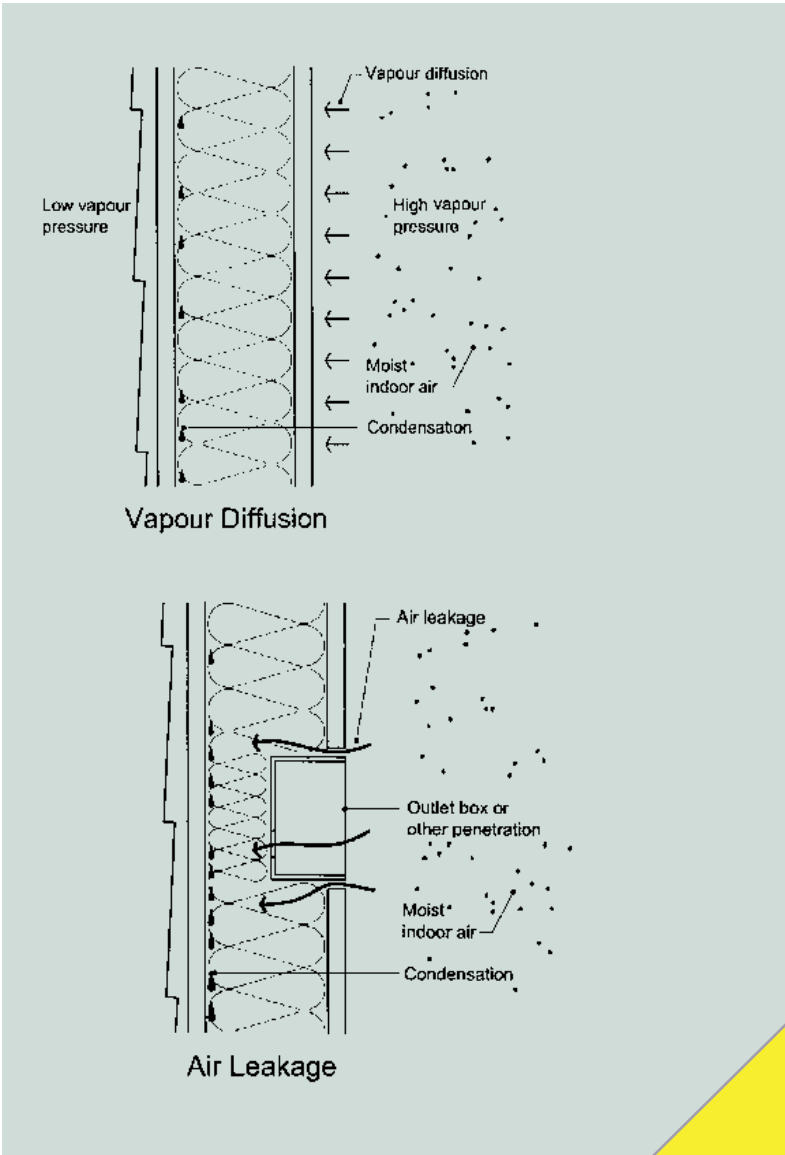

**TABLE 1:** Performance Expectations for Exterior Wall and Window Moisture Control Strategies

Exposure Level	Face Seal	Concealed Barrier	Rainscreen	Pressure Equalized Rainscreen
High	Poor	Poor	Fair	Good
Medium	Poor	Poor	Good	Good
Low	Fair	Good	Good	Good
None	Good	Good	Good	Good

## Moisture Design for Wood-Frame Buildings

The moisture sources and transport mechanisms that impact buildings are numerous and complex. Control strategies must be developed to effectively deal with each of these sources and mechanisms. However, a number of recent studies have concluded that the primary failure mechanism with respect to moisture is rainwater penetration through exterior walls. This has been particularly evident in several wet, humid coastal regions of North America, such as Wilmington, Seattle or Vancouver. Development of strategies for rain penetration control is the first priority in design for durability. Control of condensation caused by vapour penetration (see Figure 6) and groundwater are additional – though secondary – concerns. In both cases the strategy should meet the degree of the hazard or moisture load.



**FIGURE 6:** Driving Forces for Vapour Penetration

**FIGURE 7:** Main Driving Forces for Rainwater Penetration

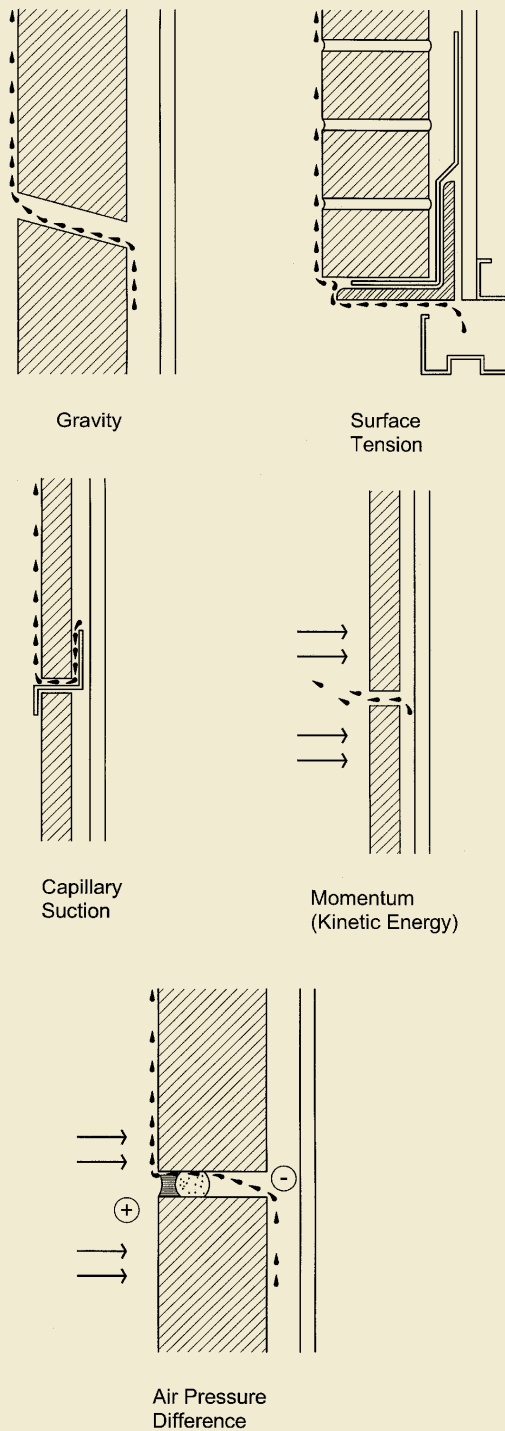

## Rain Penetration Control

There are two general strategies for rain penetration control:

- minimize the amount of rainwater contacting the building surfaces and assemblies
- manage the rainwater deposited on or within assemblies

The dynamics of rainwater penetration are well established. Water penetration through a building assembly is possible only when three conditions occur simultaneously:

- an opening or hole is present in the assembly
- water is present near the opening
- a force occurs to move the water through the opening

This is true of all water penetration and has been expressed as a conceptual equation:

$$\text{water} + \text{opening} + \text{force} = \text{water penetration}$$

The minimum size of opening which will allow water penetration varies in relation to the force driving the water.

To control water penetration, it is necessary to understand the underlying driving forces that may be present. These can include gravity, surface tension, capillary suction, momentum (kinetic energy) and air pressure difference (see Figure 7)

It follows that water penetration can be controlled by eliminating any of the three conditions necessary for penetration. Building design and detailing strategies can be developed that:

- reduce the number and size of openings in the assembly
- keep water away from any openings
- minimize or eliminate any forces that can move water through openings

## The 4Ds

These general water management strategies have been further articulated into a set of design principles called *the 4Ds: deflection, drainage, drying and durable materials*. With respect to rain penetration control, deflection refers to design elements and details that deflect rain from the building minimizing rainwater loads on the building envelope. Drainage, drying and durable materials are principles that deal with the management of water once it has reached or penetrated the envelope.

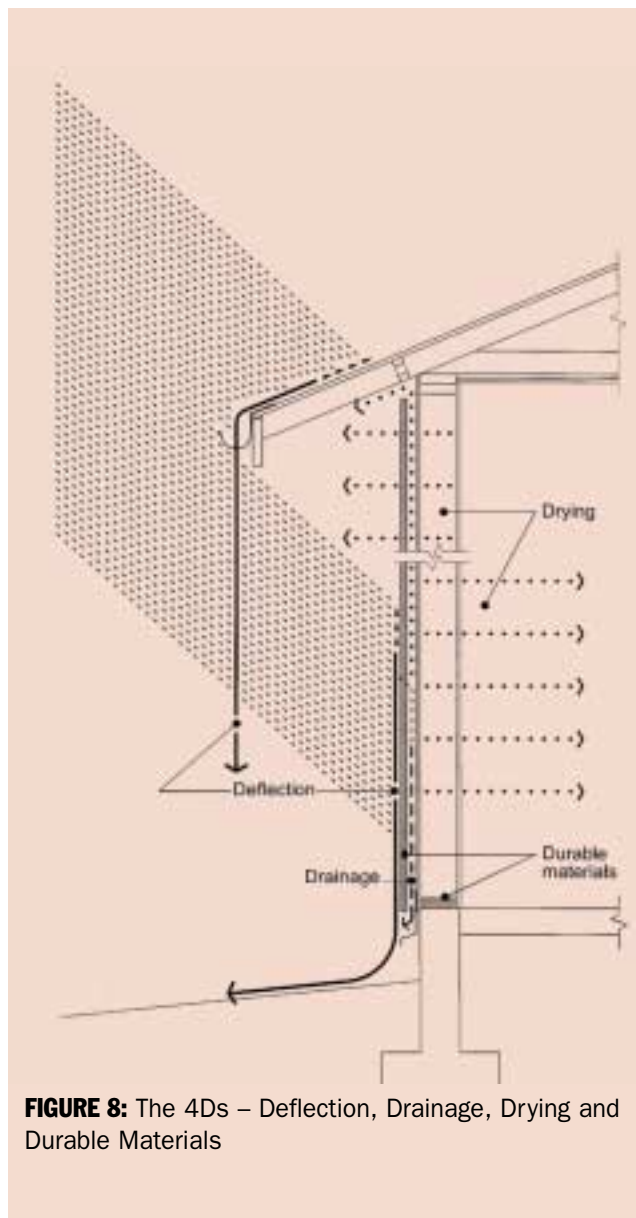

**FIGURE 8:** The 4Ds – Deflection, Drainage, Drying and Durable Materials

These principles can be applied to design at two distinct scales. At the macroscale, there are *design patterns* that involve the manipulation of building and roof form, massing, siting, material expression and even issues of style. At the microscale, there are *detail patterns*, which determine whether water management works or does not work. Detail patterns involve the relationships between materials, installation sequencing, constructability and economy of means. Many of these patterns, developed empirically by trial and error, have been used by builders for centuries, whereas others have been developed more recently as a result of scientific research and testing. The principles are also applied to *material selection*.

In most exposures, effective rainwater management is accommodated by multiple lines of defense. This is often referred to as *redundancy*. The concept of redundancy involves recognizing the inherent limitations of the design and construction processes. Perfection is not easily achieved and errors in design and construction do occur. Where the degree of moisture hazard is high, these errors may have significant impacts on the envelope performance. Redundant systems provide for back-up protection, in the likely event errors are made. The 4Ds can be understood as four separate lines of defense against rain penetration and the problems that can result.

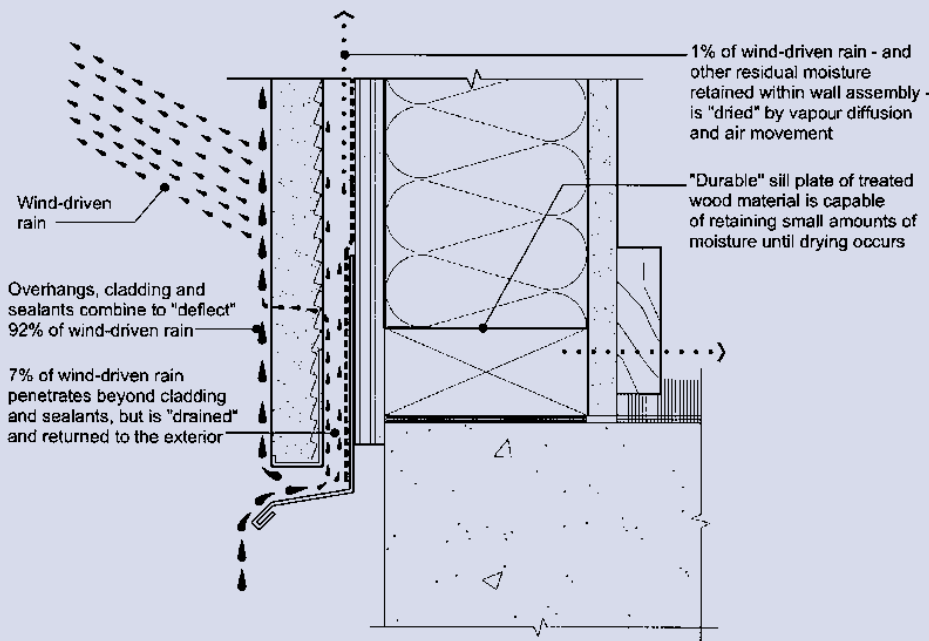

**FIGURE 9:** Four Lines of Defense – Redundancy is designed into exterior wall systems by providing multiple lines of defense. Imagine a hundred raindrops falling on a building (on a windy day). Approximately 92 drops will be deflected by the pitched roof, overhangs, projecting sills, and the face of the cladding; 7 drops will be **drained** behind the cladding over the moisture barrier, then returned to the exterior; and 1 drop will be dried by vapour diffusion and air movement. Where it is anticipated that moisture may accumulate on wood materials in the assembly, that moisture will be “held” safely by **durable materials** – in this case a pressure-treated sill plate – until it is removed by drying.

## Deflection

Deflection is the first principle and main priority of water management. The intent is to keep rainwater away from the building facade and to minimize the potential for water penetration into the envelope. The deflection principle is evident in many building design patterns that have historically proven effective at reducing the amount of rainwater on exterior walls. These include:

- 1) placing the building so it is sheltered from prevailing winds,
- 2) providing sizable roof overhangs and water collection devices at the tops of exterior walls, and
- 3) providing architectural detailing that sheds rainwater. A pitched roof with sufficiently wide overhangs is the singular design element that can help ensure the long-term durability of wood-frame buildings (see Figure 10). Deflection is applied at the smaller scale in detail patterns such as projecting sills, flashings and drip edges. Cladding and sealants are also considered to be part of the deflection line of defense. A water management strategy that relies only on deflection may be at risk in regions of North America where the hazard condition is high.

**FIGURE 10:** Effect of Overhangs on Wall Performance

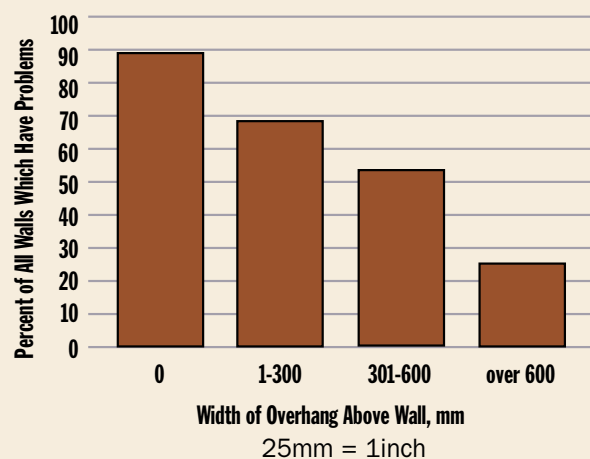

**PHOTO 4:** The Windgate townhouses near Choklit park in Vancouver, BC use decorative exterior fascia boards at the floor level, combined with sloping roofs and overhangs as part of a moisture management strategy.



**PHOTO 3:** Girvin Cabin – This wood-frame studio and house located on Decatur Island, Washington uses pronounced overhangs that are both functional by deflecting rainwater from a window wall and architectural to suit the surrounding environment.

## Drainage

Drainage is the next principle of rain penetration control, second only to deflection in terms of its capacity to manage rainwater. Building design patterns that incorporate the drainage principle include pitched roofs and sloped surfaces at horizontal elements. At the detail level, drainage is accomplished by collecting incidental moisture accumulation in the wall assembly and returning it to or beyond the exterior face of the cladding by means of gravity flow. In its simplest form, this is achieved by adding a drainage plane within the assembly, between the cladding and the sheathing. In wood-frame construction, the drainage plane typically consists of a moisture barrier (building paper, felt, or housewrap), and most importantly how they work in combination with window and door flashings. Drainage is generally the primary means of providing redundancy in a wall assembly.

A drainage cavity is a more elaborate feature that introduces an airspace between the cladding and the drainage plane/sheathing (see Figure 13 & 14). The airspace serves as a capillary break to prevent water from excessively wetting the drainage plane. The airspace, particularly when it provides a pressure-equalization function, can also be seen as another means of deflection, in that pressure-equalization neutralizes the primary driving force behind rain penetration (air pressure differential), and thereby reduces the amount of moisture being driven through the cladding into the drainage cavity.

## Drying

Drying is the mechanism by which wall assemblies remove moisture accumulations by venting (air movement) and vapour diffusion. The drying potential of both the cladding and the wall sheathing/framing

must be considered. Cavities introduced for drainage purposes also offer a means to dry the cladding material by back venting. Drying of sheathing and framing is often a separate matter and is greatly affected by the selection of moisture barrier and vapour barrier materials. Exterior wall assemblies must be designed to allow sufficient drying to either the exterior or the interior. The permeability of cladding, moisture barrier, vapour barrier and interior finish materials will greatly affect the overall drying potential of the wall. This is an area currently under study by researchers.

## Durable Materials

Durable materials must be selected for use at all locations where moisture tolerance is required. Where deflection, drainage and drying cannot effectively maintain the moisture content of wood components below 28%, the decay resistance of the wood must be enhanced. For wood framing components, this is achieved by pressure treatment with wood preservatives. The use of treated wood where sill plates are in contact with concrete foundations is a common detail pattern that follows this principle.

Building design patterns involving architectural expression should be reconciled with long-term durability considerations. Weathering properties and maintenance requirements should be considered. For example, face brick applied to wood-frame walls must be rated for exposure, and masonry wall ties must be sufficiently corrosion-resistant. Wood siding and trim with direct exposure to weather should be either naturally decay-resistant or treated wood materials.

**FIGURE 11:** Face Seal Wall Assembly

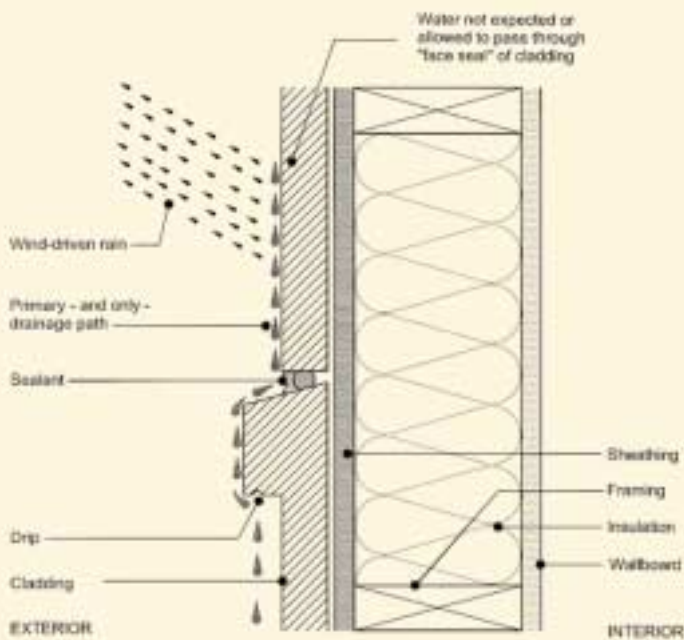

**FIGURE 12:** Concealed Barrier Wall Assembly

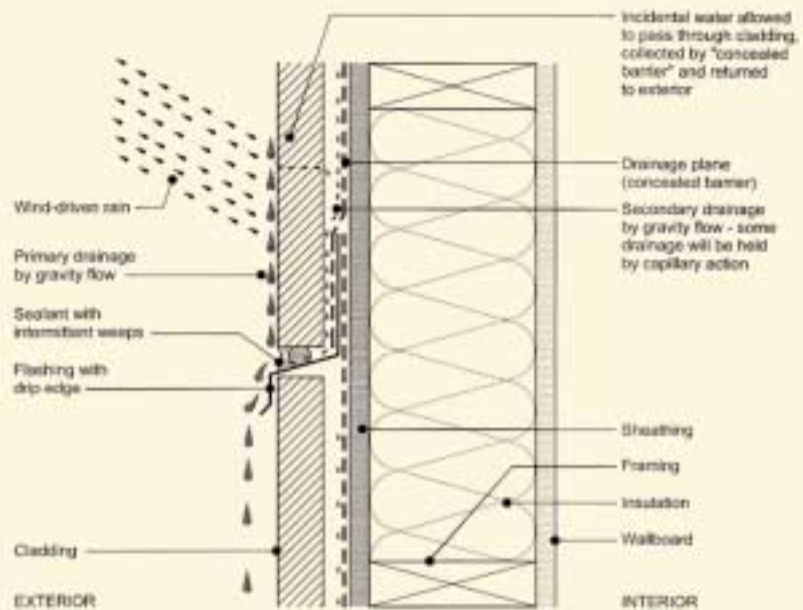

## RAINWATER MANAGEMENT STRATEGIES FOR EXTERIOR WALLS – PUTTING IT ALL TOGETHER

There are three basic exterior wall type options for wood-frame buildings, each based on a distinct conceptual strategy for rainwater management: face seal, concealed barrier and rainscreen. When designing exterior walls for a given building, there is a need to select an appropriate system and be consistent through the design and detailing phase and to clearly communicate the details of the system to the construction team.

*Face seal* walls are designed to achieve water tightness and air tightness at the face of the cladding. Joints in the cladding and interfaces with other wall components are sealed to provide continuity. The exterior face of the cladding is the primary – and only – drainage path. There is no redundancy. The “face seal” must be constructed – and must be maintained – in perfect condition to effectively provide rain penetration control. However, such reliance on perfection is questionable at walls exposed to rainwater. As a rule, face seal walls should only be used where very limited amounts of water will reach the cladding surface, such as wall areas under deep overhangs or soffits or in regions where the degree of moisture hazard is not high.

*Concealed barrier* walls are designed with an acceptance that some water may pass beyond the face of the cladding. These walls incorporate a drainage plane within the wall assembly, as a second line of defense against rain penetration. The face of the cladding remains the primary drainage path, but secondary drainage is accomplished within the wall. An example of a concealed barrier wall is wood siding installed directly over an asphalt-saturated felt moisture barrier and plywood sheathing. The water-resistant felt constitutes the drainage plane. Vinyl siding and drainage EIFS (exterior insulated finish system) installed over a moisture barrier should also be considered concealed barrier walls, although drainage in these cladding systems is enhanced by provision of some airspace – however discontinuous – behind the cladding. A concealed barrier strategy is appropriate for use on many exterior walls and can be expected to perform well in areas of low to moderate exposure to rain and wind. Performance in high to severe exposure conditions, however, is not assured. In all cases, the integrity of the second line of defense is highly dependent on correct detailing by the designer and proper installation by the builder. To maximize performance and service life of the assembly in high exposure conditions, consideration should be given to the use of a rainscreen assembly.

**Rainscreen** walls take water management one step further by incorporating a drainage cavity (3/8" minimum width) into the assembly, between the back of the cladding and the building paper. The drainage cavity offers enhanced protection from water intrusion by acting as a capillary break, thereby keeping most water from making contact with the moisture barrier. The airspace also serves to ventilate the backside of the cladding, which facilitates drying of the cladding, and mitigates against potential moisture accumulation in the wall framing caused by reverse vapour drive. Examples of rainscreen walls include brick veneer (usually installed with a one or two-inch airspace) and stucco cladding installed over vertical strapping (typically pressure-treated 1x3s at 16" o.c. on center). Rainscreen walls are appropriate for use in all locations where high exposure to rain and wind is likely.

**FIGURE 13:** Rainscreen Wall Assembly

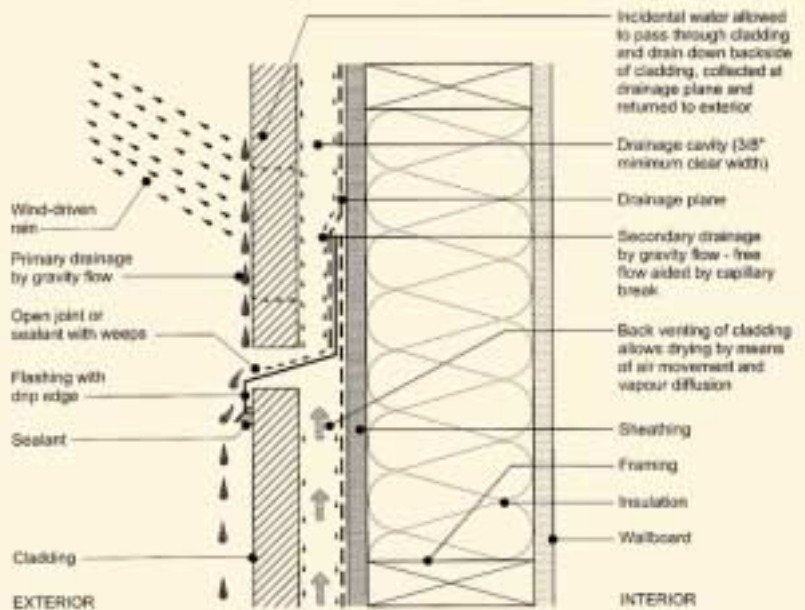

**Pressure-equalized rainscreens** represent an advancement of the basic rainscreen strategy. These walls incorporate compartmentalization and increased venting of the drainage cavity to improve performance. As wind blows on a wall face, air passes through vents into the cavity behind the cladding. If this air is contained appropriately by subdividing the drainage cavity with compartment seals, an equalization of pressure occurs across the cladding, thereby eliminating one of the key driving forces behind water penetration. This strategy is most commonly applied to brick veneer walls, though conceptually it is possible to enhance any rainscreen assembly with this technology. Pressure-equalized rainscreens are appropriate for use on all exposures and offer the highest performance potential with respect to water management.

**FIGURE 14:** Pressure Equalized Rainscreen Wall

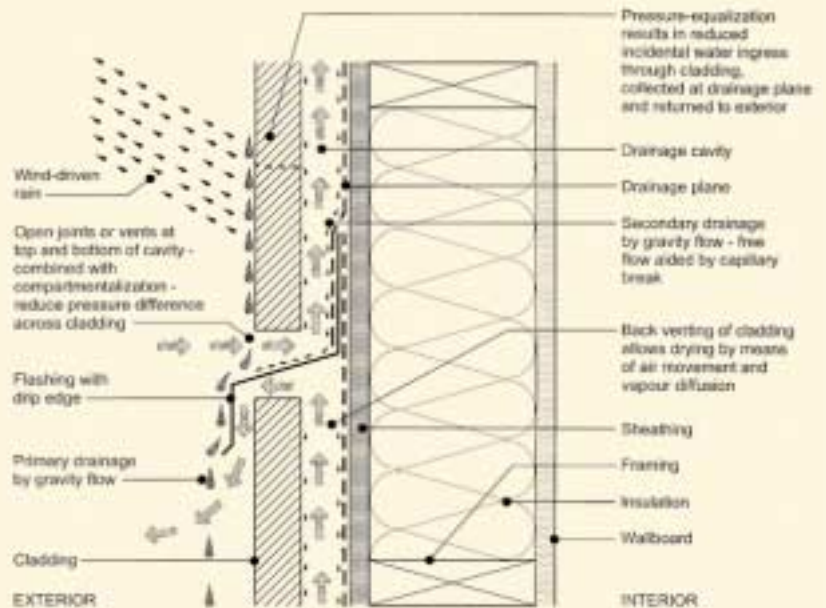



# Quality Assurance During Construction

Long-term durability is a function of the quality of design, construction, operation and maintenance of a building. To achieve durability, *quality assurance* is essential at every stage in the life of the building. Quality assurance is defined as all those planned and systematic actions needed to confirm that products and services will satisfy specified requirements. A fundamental principle of quality assurance is that all persons accept responsibility for the standard of their own work. In order to avoid durability problems, adequate and coordinated quality control obligations should be imposed upon all persons involved and during all phases in the process of defining, planning, building, operating and maintaining the structure until the end of its service life.

It is widely acknowledged that design and construction quality have been compromised in recent decades by tighter project budgets and schedules, the use of unskilled labor, as well as the use of new materials and technologies. In response to the perceived decline in quality, several code and standards organizations in North America have established guidelines for durable buildings. *ASTM E 241-00 – Standard Practices for Increasing Durability of Building Constructions Against Water-Induced Damage*, first released in 1990, provides a list of principles and recommended practices for effective water management. *CSA S478-95 – Guideline on Durability in Buildings*, published in 1995, is considerably more comprehensive. It contains an extensive outline of quality assurance procedures for building design, construction, operation and maintenance.

**TABLE 2:** Quality Assurance and the Building Process

Stage in Building Life Cycle	Quality Assurance Activity
Conception	<ul style="list-style-type: none"> <li>• establish appropriate levels of <i>performance</i> for building and <i>components</i></li> </ul>
Design - detail - specify	<ul style="list-style-type: none"> <li>• prescribe <i>performance</i> criteria for materials, <i>components</i>, and <i>assemblies</i></li> <li>• confirm acceptability and achievability of <i>performance</i></li> <li>• specify test options (prototype, in situ, etc)</li> </ul>
Tendering	<ul style="list-style-type: none"> <li>• review design documents, including <i>performance</i> specifications</li> <li>• accept requirements (contractor)</li> <li>• accept tender(s) (owner)</li> </ul>
Construction	<ul style="list-style-type: none"> <li>• control through               <ul style="list-style-type: none"> <li>- review of process and product</li> <li>- sampling and testing</li> <li>- correction of deficiencies</li> <li>- certification of work</li> </ul> </li> </ul>
Handover	<ul style="list-style-type: none"> <li>• commissioning               <ul style="list-style-type: none"> <li>- verification of <i>performance</i> of completed building by testing under operational loads</li> </ul> </li> </ul>
Operation and Maintenance	<ul style="list-style-type: none"> <li>• monitor <i>performance</i></li> <li>• inspect for deterioration or distress</li> <li>• investigate problems</li> <li>• certify work</li> </ul>
Renovation	<ul style="list-style-type: none"> <li>• same as for Conception and Design, above</li> </ul>

*With the permission of CSA International, material is reproduced from CSA Standard S478-95, Guideline on Durability of Buildings, which is copyright by CSA International, 178 Rexdale Blvd., Toronto, Ontario, M9W 1R3. While use of this material has been authorized, CSA International shall not be responsible for the manner in which the information is presented, nor any interpretations thereof.*

## Construction Quality Control

Proper design alone will not ensure the delivery of a durable building to the owner. The construction process must follow through with the design intent. This begins in the design phase with construction documentation. The design of the building envelope should be clearly communicated to the entire construction team. The various moisture control strategies should be communicated, perhaps as a narrative description and concept drawing on the cover sheet of the drawings. Critical details, including both typical and non-typical conditions, should be provided to installers. Details should be adequately considered with respect to constructability and the overall water management strategy of the wall. Large-scale drawings, and in some cases three-dimensional drawings, are needed to visibly indicate the relationships of various components in the assembly. In particular, the drainage plane (moisture barrier and flashings) must be clearly articulated in the detailing. If the design intent and assumptions are not clearly articulated, it is quite possible that installers will misinterpret the details during construction.

The builder should develop a rigorous set of procedures for quality control during construction. Coordination of the work is essential to ensure long-term performance, particularly with the building envelope, where many different trades must interface. Submittals, shop drawings and pre-installation meetings are all tools that should be used during the construction phase to clarify, refine and verify the design. Mock-ups are another useful tool, allowing the designer and builder to work with the various trades involved in the building envelope construction and resolve issues related to constructability and sequencing. Once tested and approved, mock-ups can be used to establish a visible and tangible standard for the work that follows.

## Material Handling

Control of moisture during construction is also important. Even when dry lumber is purchased and delivered to the jobsite, it can be wetted prior to or during construction. Procedures should be developed to:

- keep wood-based materials dry while in storage onsite,
- minimize wetting of installed materials, and
- promote drying of materials with venting, heating or dehumidification.

Wood materials that are exposed to wetting should be dried to 19% moisture content or less prior to enclosure within assemblies. On buildings that are exposed to significant wetting during construction, schedules should provide an allowance for proper drying to framing and sheathing materials. Moisture barriers, installed soon after assemblies are framed, can be used to minimize exposure to weather. Mechanical measures, such as provision of artificial heat and/or dehumidification, can be utilized to speed the drying process.

## Conclusion

Wood-frame buildings have an established record of long-term durability. Wood will continue to be the material of choice due to its environmental advantages, ease of use and cost competitiveness. With the correct application of building envelope design principles, all materials can perform well with regards to durability.

The imperative for durable construction goes beyond creating healthy buildings as we must build durably to minimize the environmental impacts of our society. In fact, wood buildings perform well against other materials when considered from a life cycle cost perspective that factors things like greenhouse gas emissions, water pollution index, energy use, solid waste and ecological resource use. However, the environmental advantages of wood can only be achieved if the building is designed and constructed for long-term durability.

With passion and eloquence, the architect James Cutler has spoken of “honouring the wood” through the building design and detailing process. This would include the concept of protecting wood from moisture, which is the essence of designing for durability.



**PHOTO 5:** Rafter Tail Detail, Paulk Residence, by James Cutler

### Credits:

**Front Cover:** Architect – CBT Architects  
Photographer – Edward Jacoby

**Back Cover:** Architect – Hughes Baldwin Architects  
Photographer – Peter Powles

**Photo 1:** Photographer – Klaus Brinkmann

**Photo 2:** Developer – Polygon Lanesborough Development Ltd.  
Architect – Neale Staniszki Doll  
Adams Architects  
Building Envelope Engineer – Morrison Hershfield Ltd.

**Photo 3:** Architect – Miller|Hull Partnership  
Photographer – Michael Skott

**Photo 4:** Architect – Nancy Mackin Architecture  
Photographer – Anthony Redpath & Peter Powles

**Photo 5:** Architect – James Cutler  
Photographer – Art Grice

**Figure 3 & 4:** *Builder's Guide*,  
Building Science Corporation

**Figure 5 & Table 1:**  
*Best Practice Guide for Wood-Frame Envelopes in the Coastal Climate of British Columbia*,  
Canada Mortgage and Housing Corporation, [www.cmhc-schl.gc.ca](http://www.cmhc-schl.gc.ca)

**Figure 10:** *Survey of Building Envelope Failures in the Coastal Climate of British Columbia*,  
Canada Mortgage and Housing Corporation, [www.cmhc-schl.gc.ca](http://www.cmhc-schl.gc.ca)



Canadian  
Wood  
Council

Conseil  
canadien  
du bois



### **Canadian Wood Council**

1400 Blair Place, Suite 210  
Ottawa, ON K1J 9B8  
Tel: 1-800-463-5091  
Fax: 1-613-747-6264  
e-mail: [info@cwcc.ca](mailto:info@cwcc.ca)

---

#### **Our Web Sites:**

Wood Durability:  
[www.durable-wood.com](http://www.durable-wood.com)

Canadian Wood Council:  
[www.cwcc.ca](http://www.cwcc.ca)

Canada's Forest Network  
[www.cfn.ca](http://www.cfn.ca)

Wood Design & Building Magazine:  
[www.wood.ca](http://www.wood.ca)

WoodWorks® Design Office Software:  
[www.woodworks-software.com](http://www.woodworks-software.com)

WoodWORKS! Project:  
[www.wood-works.org](http://www.wood-works.org)